



REFRIGERATOR

BUILT IN REFRIGERATOR

BASIC MODEL : DRF367500AP/DA

MODEL CODE : DRF367500AP/DA

BRF365200AP/AA

SERVICE *Manual*

REFRIGERATOR



CONTENTS

1. PRECAUTIONS (SAFETY WARNINGS).....4
2. PRODUCT SPECIFICATIONS8
3. FULL DISASSEMBLY AND ASSEMBLY ...15
4. TROUBLESHOOTING34
5. PCB DIAGRAM.....80
6. BLOCK DIAGRAM86
7. REFERENCE INFORMATION.....87



WARNING

IMPORTANT SAFETY NOTICE

The service guide is for service men with adequate backgrounds of electrical, electronic, and mechanical experience.

Any attempt to repair a major appliance may result in personal injury and property damage.

The manufacturer or dealer cannot be responsible for the interpretation of this information.

Dacor
Technical Service Guide
Copyright ©2017

Contents

1. Precautions (safety warnings)	4
2. Product specifications	8
2-1) Product Specifications	8
2-2) Dimensions of Refrigerator (Inches)	11
2-3) Refrigeration Cycle.....	12
2-3-1. Cold Air Circulation	13
2-4) Interior Overview	14
3. Full disassembly and assembly	15
3-1) PRECAUTION	15
3-2) Internal Dispenser	17
3-3) Handle & Cover Comp & Freezer Door	19
3-4) Bin & Shelf & Drawer.....	20
3-5) Ice Maker	21
3-6) DAMPER.....	22
3-7) Case Water Filter	25
3-8) Freezer Door	26
3-9) Unit	28
3-10) Case water filter & Water valve.....	29
3-11) Pcb Bo.....	30
3-12) Procedure of Service lokring	31
3-13) Evap.....	32
3-14) COMPRESSOR.....	33
4. Troubleshooting	34
4-1) Function for failure diagnosis	34
4-1-1. Test Function (Forced Operation/ Forced Defrost Function).....	34
4-1-2. Self-diagnosis function.....	38
4-1-3. Load Condition Display functions.....	44
4-1-4. Operation Condition Restore Function For Blackout.....	47
4-1-5. Cooling Off Setting Function.....	47
4-1-6. Display function of Communication error	48
4-1-7. Entering AP Mode and Smart Home Product Registration.....	48
4-1-8. MAC Address Display Mode	49
4-1-9. Option Setting Function	50
4-2) Diagnostic method according to the trouble symptom (Flow Chart)	62
4-3) Case Output Terminal.....	64
4-4) How to Enter the Test Mode	67
5. PCB Diagram	80
5-1) PBA Layout with part position.....	80

Contents

5-2) Connector Layout & Descriptions of Inverter Controller Board	81
5-3) Connector Layout with part position (Main Board)	82
5-4) Connector Layout with part position (Inverter PBA, SMPS PBA)	83
5-5) Network PBA(DA92-00960A)'s Pin assignment.....	84
5-6) Wi-Fi Module(4709-002331)'s Pin Assignment.....	85
5-7) USB_HUB PBA(DA92-00961A)'s Pin Assignment	85
6. Block Diagram.....	86
6-1) Whole block diagram	86
7. Reference information.....	87
7-1) Trouble Shooting.....	87
7-2) Q&A.....	89



1. PRECAUTIONS (SAFETY WARNINGS)

- Unplug the appliance before replacing or repairing electrical parts.
→ Be careful to avoid electric shock.
- When exchanging the parts, use the correct parts.
→ Check the model name, rating voltage, rating current, running temperature symbols.
- When troubleshooting, connect firmly the types of harness.
→ Make not to be separated when some power is imposed.
- Check the traces of water infiltration at the electric parts.
→ If there is a trace of water infiltration, exchange or tape the parts.
- Check the assemble status of parts after troubleshooting.
→ It must be in the same assembled state when compared with the state before disassembly.
- Check the use circumstance of refrigerator.
→ If the refrigerator is installed at the place that is damp or wet, or status of installation is unstable, change the installation place.
- Ground the refrigerator properly
→ Particularly, Be sure to earth when there is a risk of an electric leakage by humidity or wetness.
- Do not use multi plugs in a plug socket at the same time.
Check if the power cord and socket is damaged, pressed, squeezed, or fired.
→ If the plug or plug socket is damaged, repair or exchange it immediately.
- Do not allow consumers to repair the appliance by themselves.
- Do not store other materials except the foods.
→ Drugs or scientific materials : difficult to keep precise temperature.
→ The inflammables(alcohol, benzene, ether, LP gas, butane gas etc.): have risk of explosion.







PRECAUTIONS (SAFETY WARNINGS)

Read all instructions before repairing the product and keep to the instructions in order to prevent danger or property damage.

CAUTION/WARNING SYMBOLS DISPLAYED







	Warning	Indicates that a danger of death or serious injury exists.
	Caution	Indicates that a risk of personal injury or material damage exists.

SYMBOLS

	means Prohibition".
	means Do not disassemble".
	means No contact".
	means The things to be followed".
	means Power cord should be unplugged from the consent".
	means Earth to prevent Electric shock".



Warning & Caution

 <p>Unplug the appliance before servicing or replacing electrical parts.</p> <ul style="list-style-type: none"> • It may cause electric shock. 	 <p>Use the rated components on the replacement.</p> <ul style="list-style-type: none"> • Check the correct model, rated voltage, rated current, operating temperature and so on. 	 <p>On repair, make sure that the wires such as harness are bundled tightly.</p> <ul style="list-style-type: none"> • Bundle tightly wires in order not to be detached by the external force and then not to be wetted.
 <p>On repair, remove completely dust or other things of housing parts, harness parts, and check parts.</p> <ul style="list-style-type: none"> • Cleaning may prevent the possible fire by tracking or short. 	 <p>After repair, check the assembled state of components.</p> <ul style="list-style-type: none"> • It must be in the same assembled state when compared with the state before disassembly. 	 <p>Check if there is any trace indicating the permeation of water.</p> <ul style="list-style-type: none"> • If there is that kind of trace, change the related components or do the necessary treatment such as taping using the insulating tape.

PRECAUTIONS (SAFETY WARNINGS)

※ Please let users know following warnings & cautions in detail.



Warning & Caution



Do not allow users to put bottles or kinds of glass in the freezer.

- Freezing of the contents may inflict a wound.



Do not allow users to store narrow and lengthy bottles or foods in a small multipurpose room.

- It may hurt you when refrigerator door is opened and closed resulting in falling stuff down.



Do not allow users to store pharmaceutical products, scientific materials, etc., in the refrigerator.

- The products which temperature control should not be stored in the refrigerator.



Do not allow users to insert the power plugs for many products at the same time.

- May cause abnormal generation of heat or fire.



Do not allow users to disassemble, repair or alter.

- It may cause fire or abnormal operation which leads to injury.



Do not allow users to bend the power cord with excessive force or do not have the power cord pressed by heavy article.

- May cause fire.



Do not allow users to store articles on the product.

- Opening or closing the door may cause things to fall down, with may inflict a wound.



Do not allow users to install the refrigerator in the wet place or the place which water splashes.

- Deterioration of insulation of electric parts may cause electric shock or fire.



Make sure of the earth.

- If earthing is not done, it will cause breakdown and electric shock.

PRECAUTIONS (SAFETY WARNINGS)

WARNING

Be careful, otherwise people who are helping may be injured or the appliance may be damaged. The appliance is very heavy.

1. Transport the appliance to a suitable installation location with suitable means of transportation (trolley, lifting truck or hand).
2. Secure the appliance during transportation to prevent it from tipping.
3. Move and install with a minimum of two persons.
4. Be very careful to avoid floor damage. Delicate flooring should be protected with plywood, hard cardboard, or similar material
5. Before transporting the appliance, check access to the location where it will be installed (door size, maneuvering space in stairwells, etc.).

* **TIP OVER HAZARD:** This appliance is large, heavy and tips easily when not installed. Always transport in an erect position if possible. If this is not possible, transport laying on the back side. Keep doors taped shut during transport.

2. PRODUCT SPECIFICATIONS

2-1) Product Specifications

Model Name		36" FDR DACOR	36" FDR SAMSUNG	Remark
		DRF367500AP/DA	BRF365200AP/AA	
GROSS volume	Total	21.3 cu.ft (603l)		
	Freezer Room	6.8 cu.ft (192l)		
	Fridge Room	14.5 cu.ft (410l)		
Dimension	Width	36 inch (915 mm)		
	Height	83.4 inch (2118 mm)		
	Depth	23.8 inch (605 mm)		Without Panel
Weight (Net)		471.8 lb (214 kg)		
Rated (V/Hz)		AC 115V / 60Hz		
Motor Power Consumption		155W		
Heater Power Consumption		535W		
Refrigerator Type		Indirect Cooling		
Refrigerant		R600a		
Refrigerant Quantity		56g		
Freezer Performance		21.3 cu.ft (603l)		

PRODUCT SPECIFICATIONS

Model Name			36" FDR DACOR	36" FDR SAMSUNG	
			DRF367500AP/DA	BRF365200AP/AA	
Cooling Components	Compressor	Model Name	NF54K9151AM		
		Starting Type	INVERTER		
		Oil Charge	MINERAL 5		
	Evaporator	Refrigerator	FIN CROSS TYPE		
		Freezer	FIN CROSS TYPE		
	STEP MOTOR VALVE		DC12V Unipolar 1-2 Phase Excitation Method		
	Condenser		Forced or Natural Convection		
	Dryer		MOLECULAR SIEVE XH-9		
	Capillary Tube	Freezer	ID0.75 X L4000		
		Refrigerator	ID0.85 X L3700		
		Refrigerator → Freezer	ID0.85 X L3700		
	Refrigerant		R-600a		
	Freezer	THERMISTOR (F-SENSOR) PX-41C	MAX	5~-8 °F (Default: 0 °F)	
			MID		
MIN					
Refrigerator	THERMISTOR (F-SENSOR) PX41C	MAX	34 °F		
		MID	37 °F		
		MIN	44 °F		
Initial Defrost Cycle (F+R Defrost)			6 Hr ±10 Min		
F-Defrost Cycle			12~48Hr (Vary according to the using conditions)		
Idling Time			10 ± 2 Min		
F-Defrost Sensor	Model Name	THERMISTOR (PX-41C)			
		SPEC	5.0KΩ at 25 °C		
R-Defrost Sensor	Model Name	THERMISTOR (PX-41C)			
		SPEC	6 Hr ±10 Min		
Bimetal	Rated	AC 125V, 6A / 250V, 3A Alt) AC 125V, 10A / 250V, 5A			
	On/Off	ON / OFF			
	Operating Temp	40±5 °C ON, 60±5 °C OFF			
Defrost Related Components					

PRODUCT SPECIFICATIONS

Model Name		36" FDR DACOR	36" FDR SAMSUNG
		DRF367500AP/DA	BRF365200AP/AA
Electric component	Defrost Heater	AC120V 230W	
	Water Pipe Heater	DC12V / 2.3W (2EA)	DC12V / 2.3W
	Cabi Rear Heater	DC12V / 1.5W	
	French Heater	AC120V 12W	
	Valve Step	DC12V /0.7A, 3Way	
	Switch Reed	DC 200V 0.5A	
	Switch Rocker(POWER)	AC250V 16A	
	CBF-Power Cord	AC115V 10A	
	Ice Maker heater	AC120V 145W (2EA)	AC120V 145W
	Thermo Fuse (FRE/REF)	AC250V 10A, 110°c	
	Room LED Lamp	Top	2EA
Left Side		2EA	
Right Side		2EA	

PRODUCT SPECIFICATIONS

2-2) Dimensions of Refrigerator (Inches)

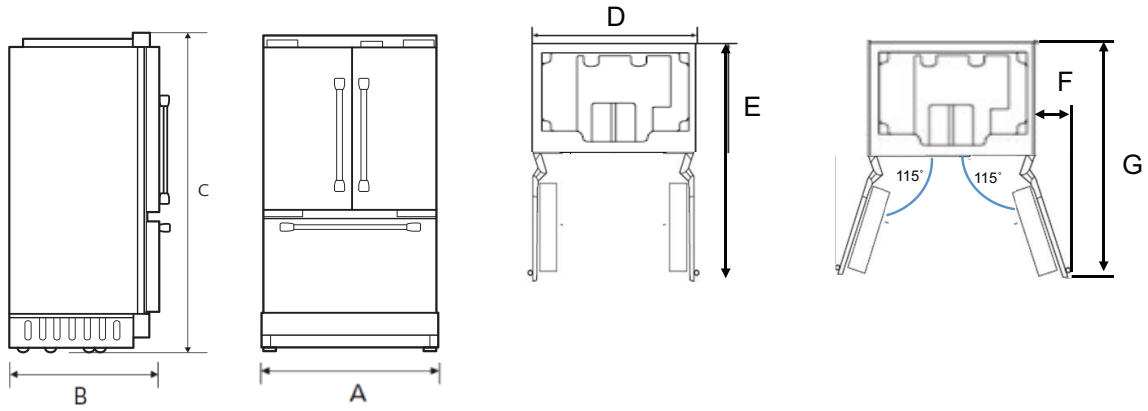

Callout	36"
A	36" (915)
B	25" (635)
C	83 3/8" (2118)
D	35 5/8" (905)
E	62 7/8" (1597)
F	20 9/16" (496)
G	61 5/16" (1556)

PRODUCT SPECIFICATIONS

2-3) Refrigeration Cycle

COMPRESSOR → IMMERGING PIPE → CONDENSER → HOT-PIPE → DRYER
→ 4-WAY VALVE → CAPILLARY CUBE(TRIPLE CAPI.)
→ EVAPORATOR → SUCTION PIPE → COMPRESSOR

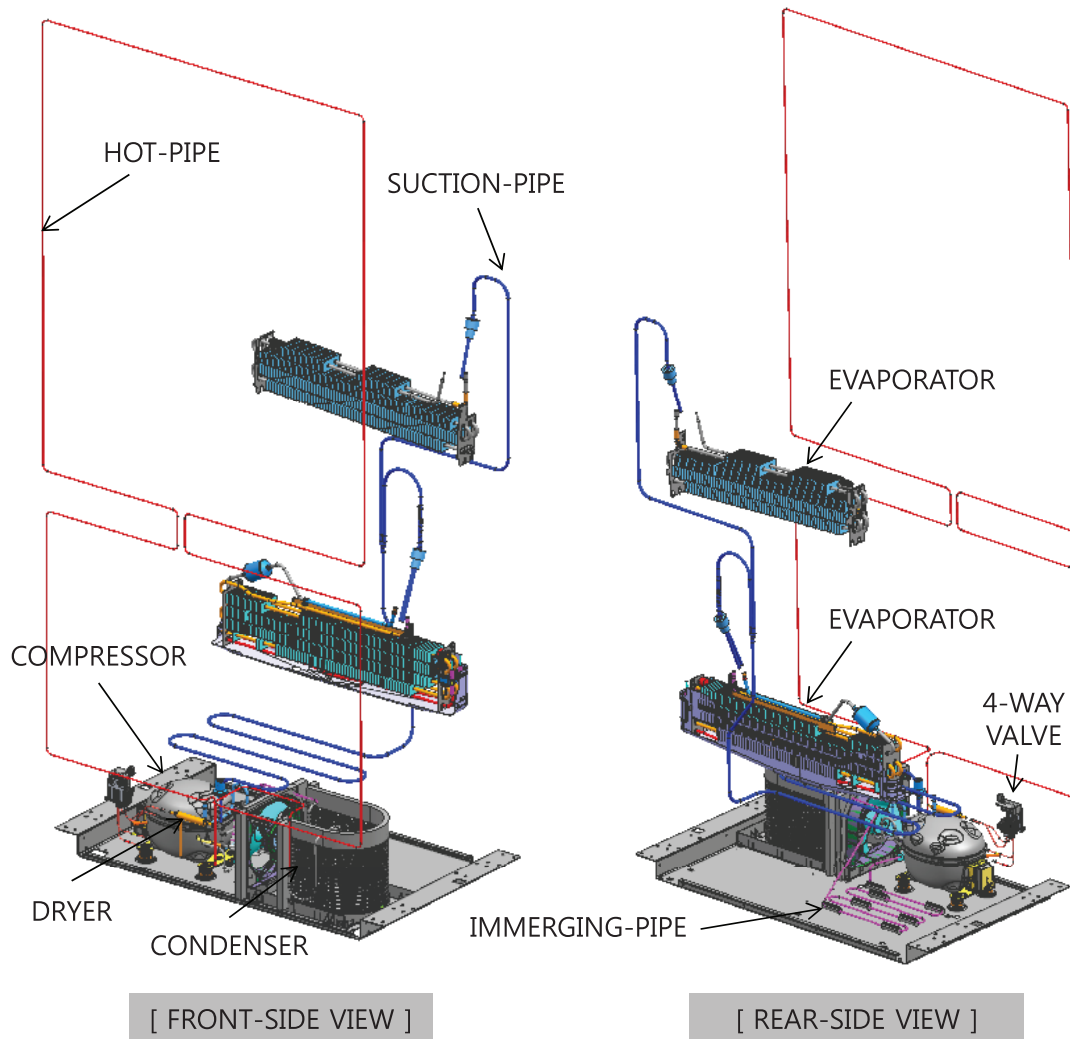

PRODUCT SPECIFICATIONS

2-3-1. Cold Air Circulation

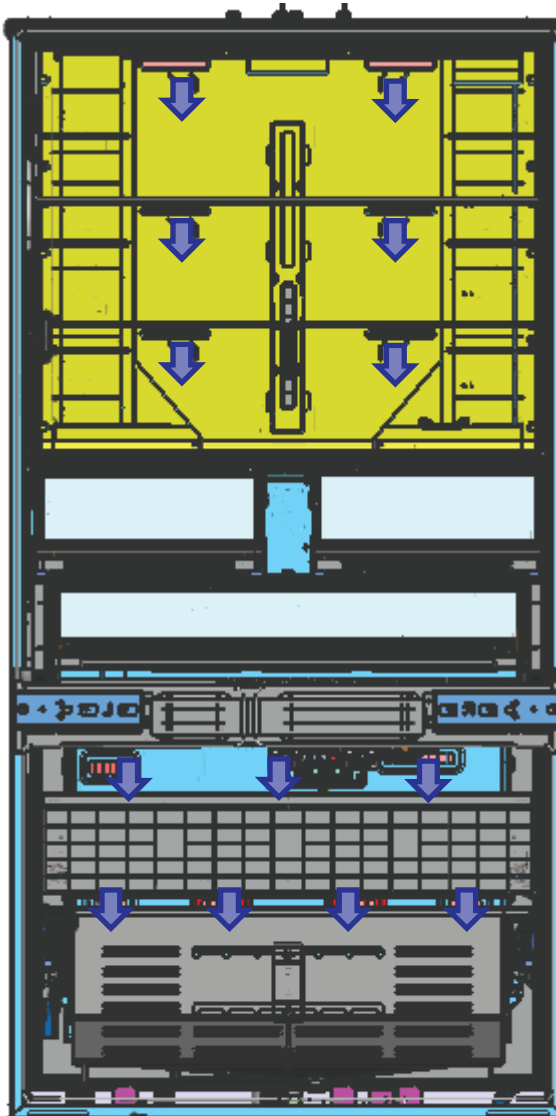

FRONT

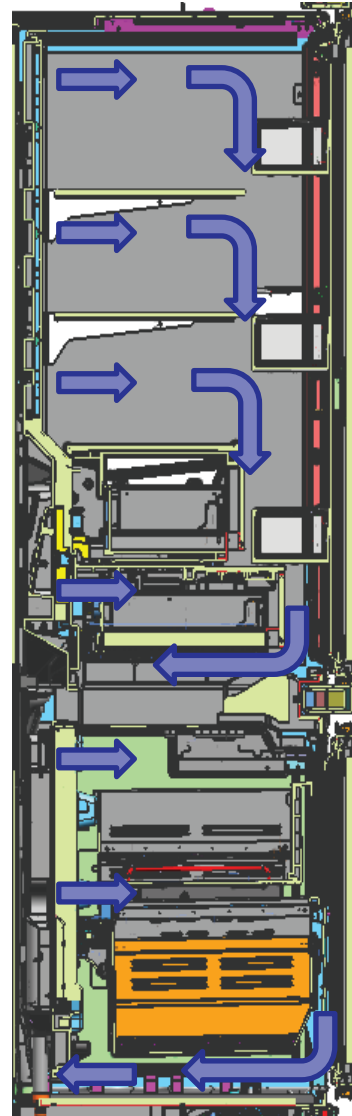

SIDE

PRODUCT SPECIFICATIONS

2-4) Interior Overview

Inside Parts, Storage, and Shelving

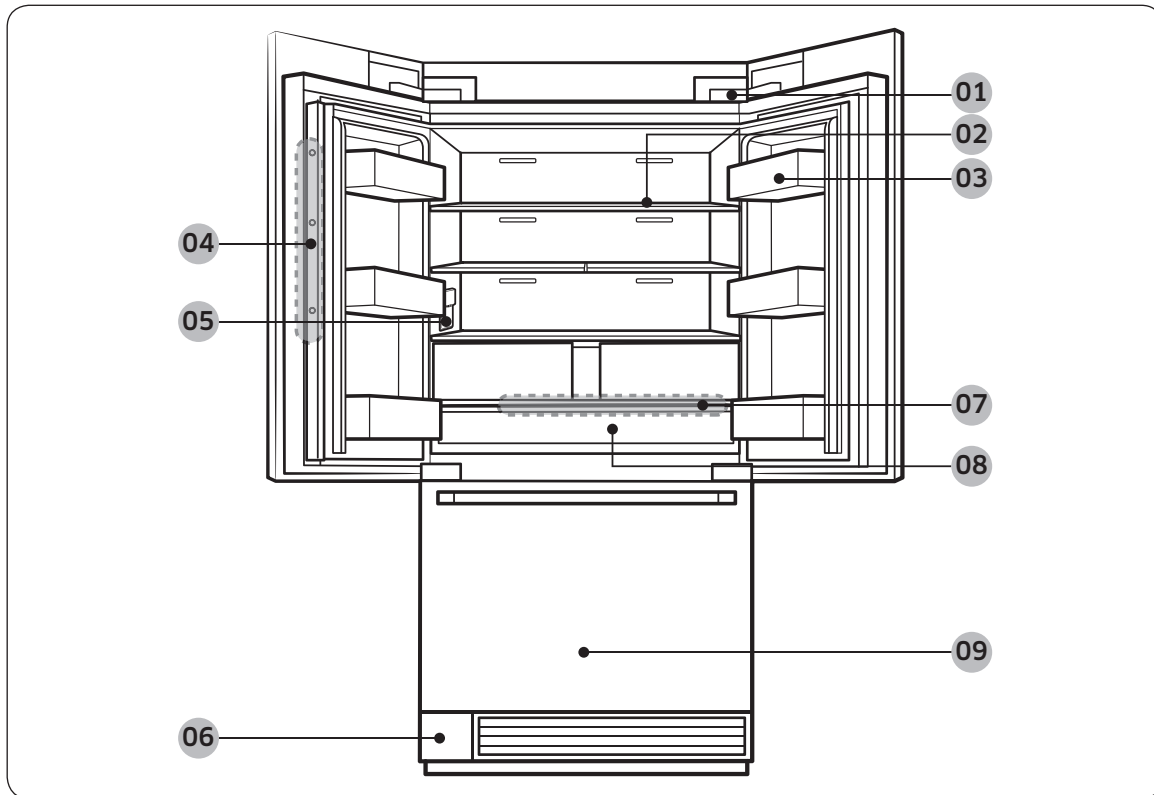

01 Power switch

02 Shelves

03 Door bins

04 Camera

05 Water dispenser

06 Water filter (cover)

07 Control panel (on FreshZone)

08 FreshZone

09 Freezer











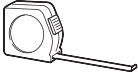
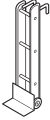

3. FULL DISASSEMBLY AND ASSEMBLY

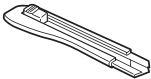
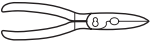
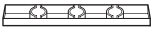
3-1) PRECAUTION

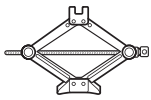
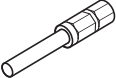
- Unplug the refrigerator before cleaning and making repairs.
- Do not disassemble or repair the refrigerator by yourself.
 - It may cause risk of causing a fire, malfunction and/or personal injury.
- Remove any foreign matter or dust from the power plug pins.
 - Otherwise there is a risk of fire.
- Do not use a cord that shows cracks or abrasion damage along its length or at either end.
- Do not plug several appliances into the same multiple power board. The refrigerator should always be plugged into its own individual electrical which has a voltage rating that matched the rating plate.
 - This provides the best performance and also prevents overloading house wiring circuits, which could cause a fire hazard from overheated wires.
- Do not install the refrigerator in a damp place or place where it may come in contact with water.
 - Deteriorated insulation of electrical parts may cause an electric shock or fire.
- The refrigerator must be grounded.
 - You must ground the refrigerator to prevent any power leakages or electric shocks caused by current leakage from the refrigerator.
- Do not put bottles or glass containers in the freezer.
 - When the contents freeze, the glass may break and cause personal injury.
- Do not store volatile or flammable substances in the refrigerator.
 - The storage of benzene, thinner, alcohol, ether, LP gas and other such products may cause explosions.

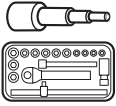

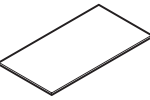

FULL DISASSEMBLY AND ASSEMBLY

- Tools required

NO	Tool		NO	Tool	
1		Electric Screwdriver	9		Stepladder
2		Measuring Tape	10		Appliance Dolly
3		Flat/Slot Head Screwdriver	11		Cutter
4		Cutter (Scissors)	12		Level
5		Adjustable Wrench	13		Jack
6		Phillips Head Screwdriver	14		Combination Wrench 3/8" (10 mm), 1/2" (13 mm)
7		Ratchet 3/8" (10 mm), 1/2" (13 mm)	15		SVC LOKRING TOOL KIT
8		Protective Floor Mat	16		UV LAMP

FULL DISASSEMBLY AND ASSEMBLY

3-2) Internal Dispenser

Part Name	How To Do	Descriptive Picture
Internal Dispenser	1. Remove the CAP DISPENSER with a flat-head screwdriver.	
	2. Unscrew one screw.	 
	3. Put a flat-head screwdriver under the ASSY, and lift it up as shown in the picture.	

FULL DISASSEMBLY AND ASSEMBLY

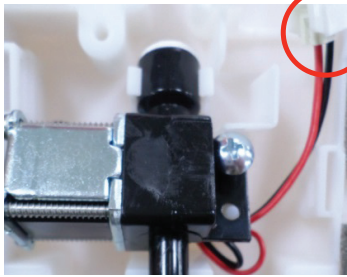
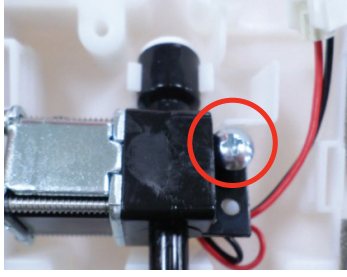
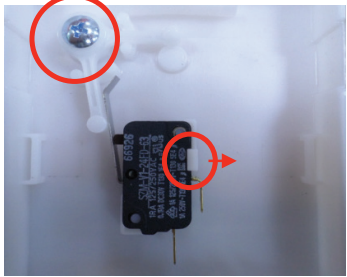
Part Name	How To Do	Descriptive Picture
Internal Dispenser	4. Pull the VALVE wire down, and disconnect the cable.	
	5. Unscrew 1 SCREW using a cross-head screwdriver.	
	6. Detach LINK using a cross-head screwdriver 7. Push the holder towards the direction of the arrow and remove the SWITCH.	

FULL DISASSEMBLY AND ASSEMBLY

3-3) Handle & Cover Comp & Freezer Door

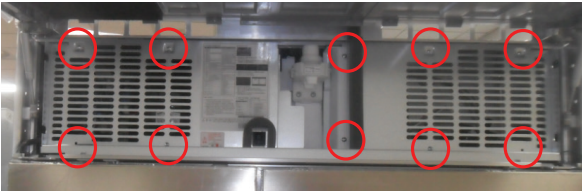
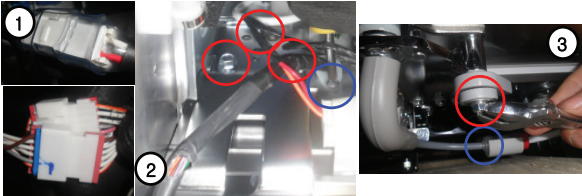
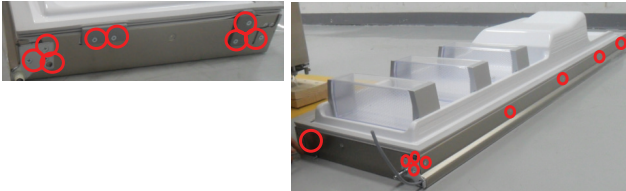
Part Name	How To Do	Descriptive Picture
ASSY-COVER COMP	① After opening the Assy Grill, disassemble 10 screws and pull out the Cover.	
DOOR	① Disconnect the 3 housings inside of Machine Compartment. ② Disassemble circled 1 screw(blue) and 3 Bolts(red) on the upper hinge. ③ Disassemble the circled 1 bolt(red) and Water Hose(blue) under the Lower Hinge.	
COVER DOOR	① Disassemble 17 Screws On the Door(Top, Bottom, Side)	





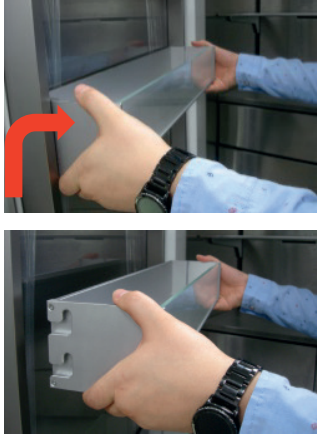
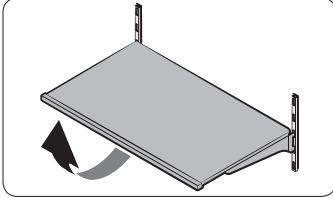
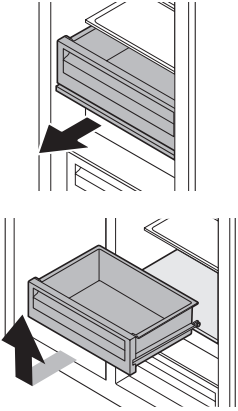

FULL DISASSEMBLY AND ASSEMBLY

3-4) Bin & Shelf & Drawer

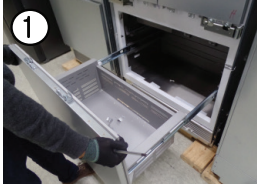
Part Name	How To Do	Descriptive Picture
<p>Bin</p>	<p>① After lifting up the Door Bin, Push it towards the chest and disassemble the Door Bin. After lifting up the door bin, push it forward and disassemble.</p>	
<p>Shelf (Common to R- and F-Room)</p>	<p>① Hold the shelf with one hand and lift the rear up with the other hand, and pull it forward.</p>	
<p>Drawer (Common to R- and F-Room)</p>	<p>① To remove, gently lift up the front of the drawer and slide out. We recommend that you remove the door bins before removing the drawer. This is to prevent damage to the door bins.</p>	



FULL DISASSEMBLY AND ASSEMBLY

3-5) Ice Maker

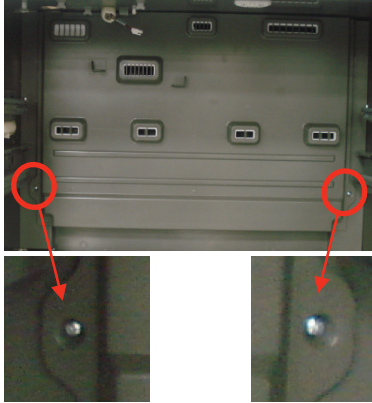

Part Name	How To Do	Descriptive Picture
Ice Maker	<p>① Remove the shelf from the freezer.</p> <p>② Remove 1 Ice-maker cover screw.</p> <p>③ Detach the cover by pulling it forward.</p> <p>④ Remove 4 Ice-maker cover screw.</p> <p>⑤ Remove the Ice-Maker by separating the housing.</p> <p>⑥ Disassemble the water supply pipe heater.</p> <p>Disassemble the water supply pipe.</p>	      

FULL DISASSEMBLY AND ASSEMBLY

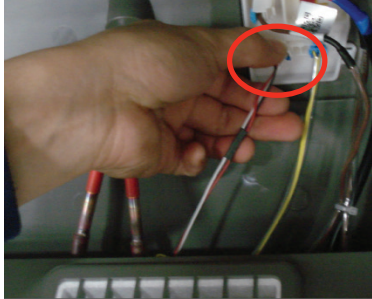
3-6) DAMPER

Part Name	How To Do	Descriptive Picture
<p>ASSY COVER EVAP Freezer (FRE)</p>	<p>1. Remove the left and right screws.</p>	
	<p>2. Pull out the bottom.</p>	
	<p>3. Remove the right upper housing.</p> <p>NOTE When reassembling, inserted it into the upper groove and press the hook.</p>	

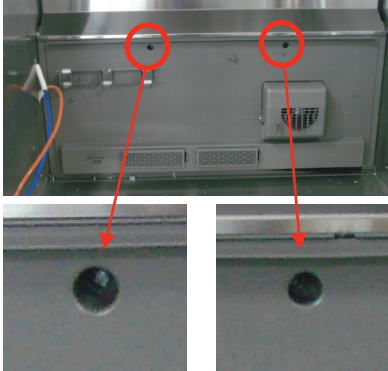
FULL DISASSEMBLY AND ASSEMBLY

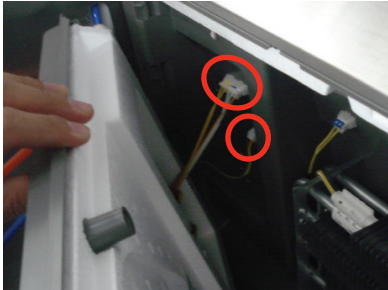
Part Name	How To Do	Descriptive Picture
ASSY COVER EVAP Fridge(REF)	1. Remove the top two screws.	
	2. Pull out the bottom.	
	3. Remove the left two housing. NOTE When reassembling, set it in the lower drain groove, and then assemble it by pressing the side hook and upper.	

FULL DISASSEMBLY AND ASSEMBLY

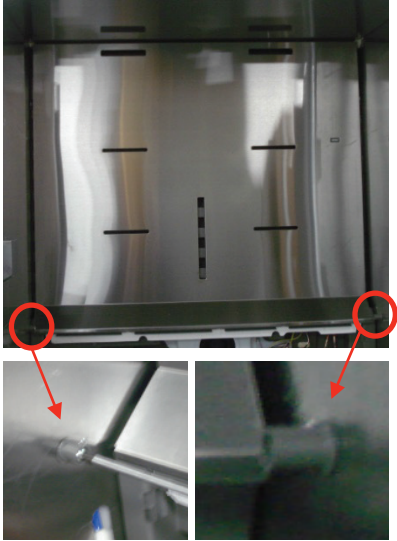
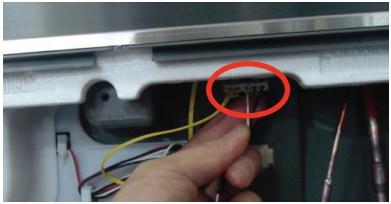
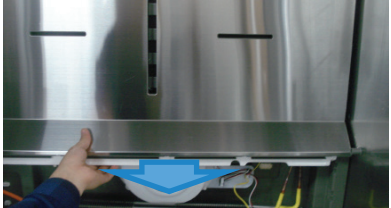
Part Name	How To Do	Descriptive Picture
ASSY COVER MULTI Fridge (REF)	1. Remove both bosses supporting the drawer shelf.	
	2. Remove the right bottom housing.	
	3. Pull out the bottom. NOTE When reassembling, inserted it into the upper groove and press the hook.	

FULL DISASSEMBLY AND ASSEMBLY

3-7) Case Water Filter

Part Name	How To Do	Descriptive Picture
<p>Case Water Filter</p>	<ol style="list-style-type: none"> ① Open the filter on the lower part of the product. ② Remove 2 Screws on the left side of the filter. ③ Detach the front cover of the machine room. ④ Remove 2 filter set screws. ⑤ Remove water supply hose fitting1. ⑥ Remove the filter case. ⑦ Remove water valve housing. 	

FULL DISASSEMBLY AND ASSEMBLY

3-8) Freezer Door

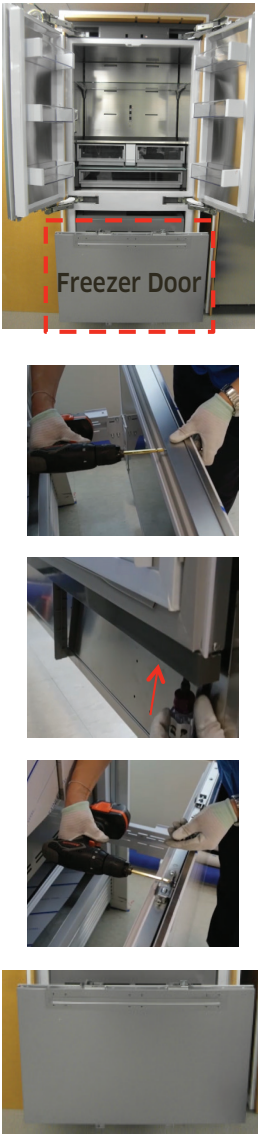

Part Name	How To Do	Descriptive Picture
<p>Freezer Panel</p>	<ol style="list-style-type: none"> ① Open the freezer door and disassemble the upper trim (unscrew two screws). ② Remove the trims on both sides of the door. ③ Remove the lower part of the trim (unscrew three screws) ④ disassemble the adjusting bolts on the upper and lower parts of the door. ⑤ Hold the handle and disassemble the panel by pulling it upward. 	

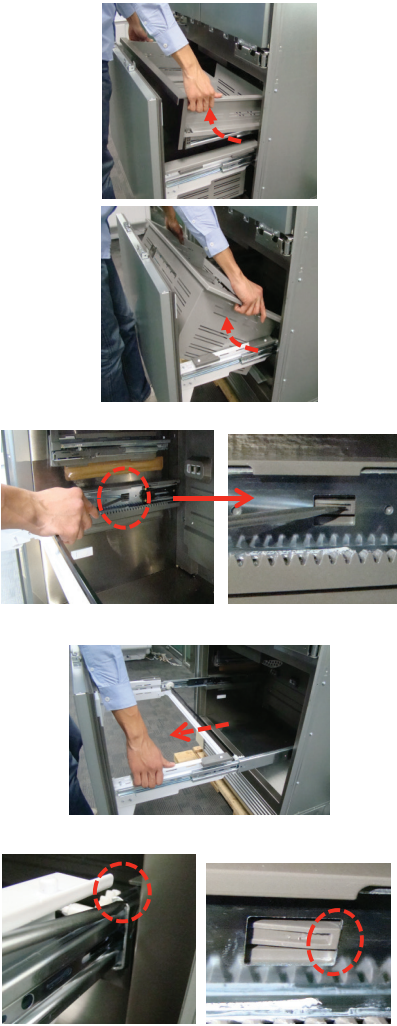
FULL DISASSEMBLY AND ASSEMBLY

Part Name	How To Do	Descriptive Picture
<p>Freezer Panel</p>	<p>⑥ Open the freezer completely, and Remove the upper container box of the freezer by pulling it forward and up.</p> <p>⑦ Remove the freezer box by holding the box and pulling it up.</p> <p>⑧ Take out the rail to its end, press the rail release buttons on both sides of the inner rail, and pull it slightly (about 10 mm).</p> <p>⑨ Disassemble the door by pulling both sides of rails forward.</p> <p>※ Attention : you might harm your feet on the door when disassembling.</p> <p>※ The installation is the reverse of removal. Close and open the door completely after installing the rail, and press the outer part of the rail with a flat-head screwdriver until you hear a clinking sound to make sure the rail lock is properly installed.</p>	



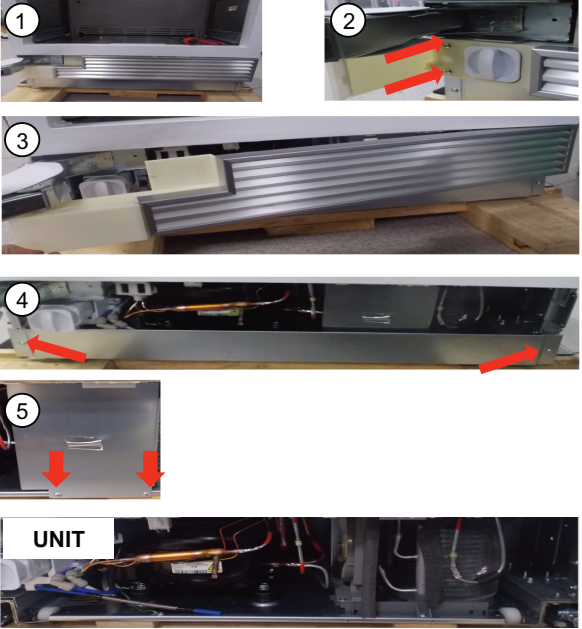
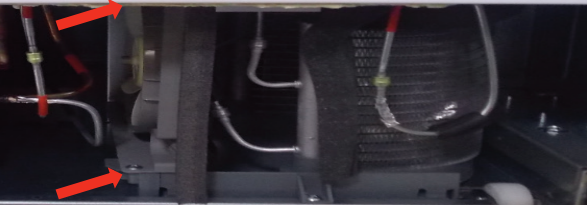





FULL DISASSEMBLY AND ASSEMBLY

3-9) Unit

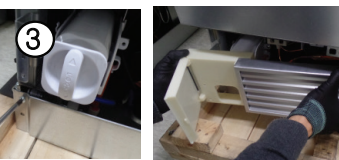
Part Name	How To Do	Descriptive Picture
<p>Unit</p>	<p>① Open the door. ② Open the Cover of the Grille and remove two Screw indicated with Arrow mark. Pull left Side of the Grille and Push it right. Then Grille will be removed. Remove Two screw of Cover comp low(Kick plate) indicated with the arrow mark. ⑤ Remove two Screw from partition.</p>	
<p>CONDENSER FAN MOTOR</p>	<p>① Remove the Screw indicated with arrow mark. ② Disassemble housing of Fan from loof ③ Pull the Fan from Unit</p>	
<p>COVER RELAY</p>	<p>① Remove the Screw and Pull out Assy case filter(you should prepare plate to spill some water in the filter) ② Remove the screw of Step valve and move Step valve to right(Prevent the break of Pipe) ③ Disassemble the Cover Relay from Compressor</p>	
<p>TRAY DRAIN WATER</p>	<p>To replace the tray, the refrigerator set must be serviced separately from the built-in furniture shelf.</p>	

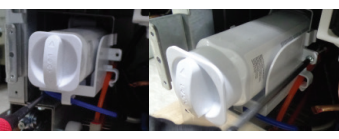

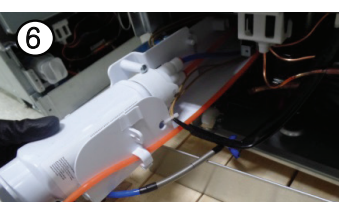



FULL DISASSEMBLY AND ASSEMBLY

3-10) Case water filter & Water valve

Part Name	How To Do	Descriptive Picture
<p>CASE WATER FILTER & WATER VALVE</p>	<ol style="list-style-type: none"> ① Open the filter on the lower part of the product. ② Remove 2 Screws on the left side of the filter. ③ Detach the front cover of the machine room. ④ Remove 2 filter set screws. ⑤ Remove water supply hose fitting1. ⑥ Remove the filter case. ⑦ Remove water valve housing. 	       

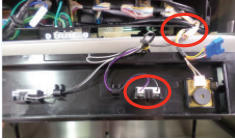
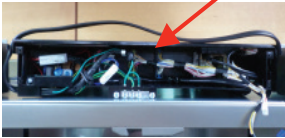
FULL DISASSEMBLY AND ASSEMBLY

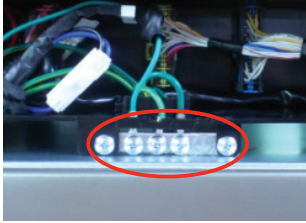
3-11) Pcb Bo

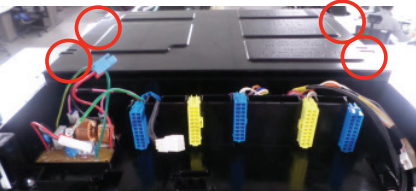
Part Name	How To Do	Descriptive Picture
Top-table	① Disassemble the Top-Table	① 
	② Unscrew Cover-Front screws (4 units) ③ Disassemble the Reed switch / buzzer connector	②  ③ 
	④ Disassemble the Cover-Front Up ⑤ Disassemble the Wi-Fi connector	④  ⑤ 
Pcb Box	⑥ Disassemble the connector	⑥ 
	⑦ Remove and unscrew Earths (3 units) and Screws (2 units)	⑦ 
	⑧ Disassemble the PCB box	⑧ 
	⑨ Unscrew the setscrews of the PCB box (4 units)	⑨ 

FULL DISASSEMBLY AND ASSEMBLY

3-12) Procedure of Service lokring

Part Name	How To Do	Descriptive Picture
<p>Procedure of Service lokring</p>	<ol style="list-style-type: none"> ① Use sand paper to remove foreign matter from the area to be bonded. ② Apply Lokprep evenly over the joint. (The required amount is about 1 g) ③ Use the SVC Lokring that meets the pipe standard, and push the pipe to the end. ④ Using the hand tool, slide the ring to the side where the center of the ring is abutted. 	

FULL DISASSEMBLY AND ASSEMBLY

3-13) Evap

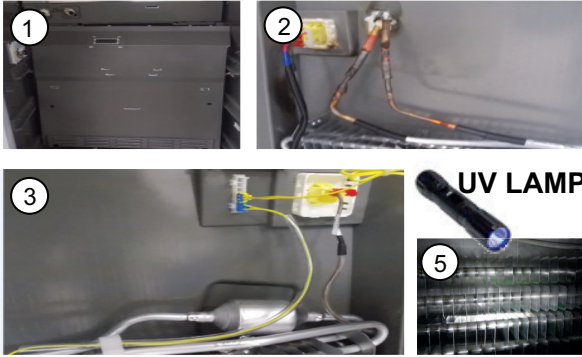
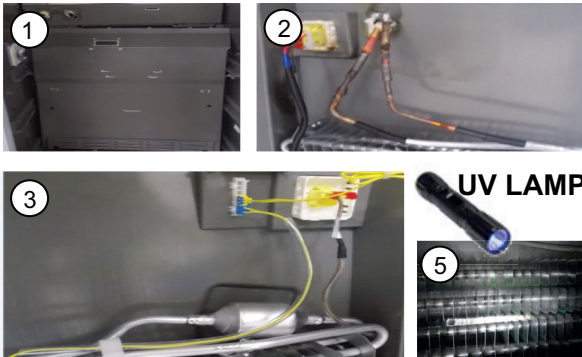
Part Name	How To Do	Descriptive Picture
<p>Freezer</p>	<ol style="list-style-type: none"> ① Open Duct first ② Remove Harness and Cut The pipe ③ Remove harness of Heater and sensor from Liner. ④ Change the Evap and connect pipe with SVC LOKRING ⑤ After operating the refrigerator, use the UV lamp to check for leaks. 	 <p>The descriptive picture for the freezer section consists of five numbered images: 1. Opening the duct. 2. Removing the harness and cutting the pipe. 3. Removing the heater harness and sensor from the liner. 4. Connecting the new evaporator to the service valve (SVC) using a Lokring. 5. Using a UV lamp to check for leaks.</p>
<p>Fridge (Refrigerator)</p>	<ol style="list-style-type: none"> ① Open Duct first ② Remove Harness and Cut The pipe ③ Remove harness of Heater and sensor from Liner. ④ Change the Evap and connect pipe with SVC LOKRING ⑤ After operating the refrigerator, use the UV lamp to check for leaks. 	 <p>The descriptive picture for the fridge section consists of five numbered images: 1. Opening the duct. 2. Removing the harness and cutting the pipe. 3. Removing the heater harness and sensor from the liner. 4. Connecting the new evaporator to the service valve (SVC) using a Lokring. 5. Using a UV lamp to check for leaks.</p>

FULL DISASSEMBLY AND ASSEMBLY

3-14) COMPRESSOR

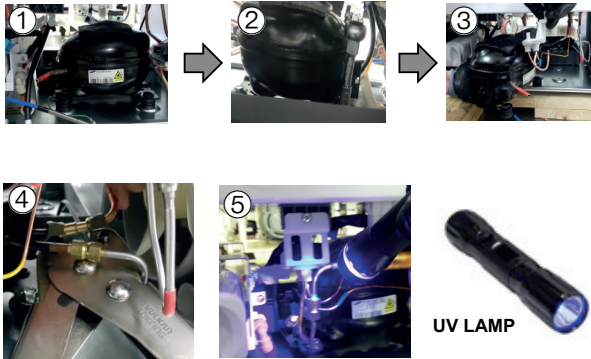
Part Name	How To Do	Descriptive Picture
<p>compressor</p>	<ul style="list-style-type: none"> ① Relay cover disassembly ② Using wrench bolt ③ Replace comp after removing valve ④ Connect pipe with SVC lokring ⑤ After operating the refrigerator, use the UV lamp to check for leaks. 	 <p style="text-align: right;">UV LAMP</p>

<p>※ Notice</p>	<p>When Lokring(Welding) service, smell may be transferred to water, so do not detach the filter, remove the entire assembly and service.</p>
------------------------	---

4. TROUBLESHOOTING

4-1) Function for failure diagnosis

4-1-1. Test Function (Forced Operation/ Forced Defrost Function)

1. When pressing both the "Control Lock" and "Freezer" keys for more than 5 seconds on PANEL PCB, the PANEL DISPLAY will be ALL ON/OFF at an interval of 0.5 sec. By leaving "control Lock" KEY and "Freezer" KEY and selecting "Control Lock" KEY at this moment, TEST MODE will be activated.
2. In the TEST MODE, every key on the Panel will function as a TEST KEY TEST MODE.
3. TEST Function changes as the TEST KEY is pressed in the following order: Forced Operation1 (FF) → Forced Operation (FF r) → Forced Operation 3(FF F) → Forced Operation 4(FF C) → Forced Operation 5(FF A) → Forced Defrost(Fd) → Cancel (Normal Operation) → Forced Operation1(FF) ...
4. The recommended way to cancel the TEST Function while running the function is to turn the power off and on.

(1) Test Mode Entering Process



(2) Test Mode Function Explanation

1) Forced Operation1



- 1-1) Pressing any KEY once in the TEST MODE will activate the Forced Operation1 function. When the Forced Operation function is activated, PANEL DISPLAY will show 'FF' on the 7-segment to indicate the Forced Operation status. At this moment, BUZZER will BEEP as an alarm.
 - 1-2) When Forced Operation1 is selected, the COMP. operates instantly without any delay in any Operation MODE.
If defrosting, Defrost will be stopped instantly, and Forced Operation will be activated.
(Attention: If Forced Operation is activated immediately after COMP OFF time, it may cause OVER-LOAD)
 - 1-3) When Forced Operation1 is selected, COMP and F-FAN will operate continuously irrespective of the interior temperature for about 24 hours.
 - 1-4) When the Forced Operation1 is activated, F-Valve will maintain Open status, and F- Cooling Speed Valve will maintain Close status and R-Valve will control the temperature.
- * When the Forced Operation is selected, the freezer compartment will select -23°C(-8°F) automatically.
 - * When Forced Operation is activated, Power Freeze function does not work. (Every KEY is entered normally)
When the Power Function is selected, the selected Power Function will turn off in ten seconds automatically
 - * When Forced Defrost or Test Cancellation is selected within a minute after Forced Operation is selected, The set temperature will return to the previous set temperature.
 - * The beep sounds of Forced Operation continue until the Operation is complete. There is no deactivate function.

TROUBLESHOOTING

2) Forced Operation2



- 2-1) Pressing any KEY twice in the TEST MODE will activate Forced Operation2 function. When the Forced Operation function is activated, PANEL DISPLAY will show 'FF r' on the 7-segment to indicate the Forced Operation status. At this moment, BUZZER will BEEP as an alarm.
- 2-2) When Forced Operation2 is selected, the COMP. operates instantly without any delay in any Operation MODE.
If defrosting, Defrost will be stopped instantly, and Forced Operation will be activated.
(Attention: If Forced Operation is activated immediately after COMP OFF time, it may cause OVER-LOAD)
- 2-3) When Forced Operation2 is selected, COMP, F-FAN, and R-FAN will operate continuously irrespective of the interior temperature for about 24 hours.
- 2-4) When the Forced Operation 2 is activated, F-Valve will maintain close status, F-Cooling Speed Valve will maintain Close status and R-valve will maintain Open status.

3) Forced Operation3



- 3-1) Pressing any KEY three times in the TEST MODE will activate Forced Operation3 function. When the Forced Operation function is activated, PANEL DISPLAY will show 'FF F' on the 7-segment to indicate the Forced Operation status. At this moment, BUZZER will BEEP as an alarm.
- 3-2) When Forced Operation3 is selected, the COMP. operates instantly without any delay in any Operation MODE.
If defrosting, Defrost will be stopped instantly, and Forced Operation will be activated.
(Attention: If Forced Operation is activated immediately after COMP OFF time, it may cause OVER-LOAD)
- 3-3) When Forced Operation3 is selected, COMP, F-FAN, and R-FAN will operate continuously irrespective of the interior temperature for about 24 hours.
- 3-4) When the Forced Operation 3 is activated, F-Valve will maintain open status, F-Cooling Speed Valve will maintain Close status and R-valve will maintain Close status.

TROUBLESHOOTING

4) Forced Operation4



- 4-1) Pressing any KEY four times in the TEST MODE will activate Forced Operation4 function. When the Forced Operation function is activated, PANEL DISPLAY will show 'FF C' on the 7-segment to indicate the Forced Operation status. At this moment, BUZZER will BEEP as an alarm.
- 4-2) When Forced Operation4 is selected, the COMP. operates instantly without any delay in any Operation MODE.
If defrosting, Defrost will be stopped instantly, and Forced Operation will be activated.
(Attention: If Forced Operation is activated immediately after COMP OFF time, it may cause OVER-LOAD)
- 4-3) When Forced Operation4 is selected, COMP, F-FAN, and R-FAN will operate continuously irrespective of the interior temperature for about 24 hours.
- 4-4) When the Forced Operation 4 is activated, F-Valve will maintain Close status, F-Cooling Speed Valve will maintain Open status and R-valve will maintain Close status.

5) Forced Operation5



- 5-1) Pressing any KEY five times in the TEST MODE will activate Forced Operation5 function. When the Forced Operation function is activated, PANEL DISPLAY will show 'FF A' on the 7-segment to indicate the Forced Operation status. At this moment, BUZZER will BEEP as an alarm.
- 5-2) When Forced Operation5 is selected, the COMP. operates instantly without any delay in any Operation MODE.
If defrosting, Defrost will be stopped instantly, and Forced Operation will be activated.
(Attention: If Forced Operation is activated immediately after COMP OFF time, it may cause OVER-LOAD)
- 5-3) When Forced Operation5 is selected, COMP, F-FAN, and R-FAN will operate continuously irrespective of the interior temperature for about 24 hours.
- 5-4) When the Forced Operation4 is activated, F-Valve will maintain Open status, F-Cooling Speed Valve will maintain Open status and R-valve will maintain Open status.

TROUBLESHOOTING

6) Forced Defrost Function



6-1) If any Key is pressed when Forced Operation5 is activated, Forced Operation 5 will immediately deactivate and switch to Forced Defrost function.

When the Forced Defrost function is activated, PANEL DISPLAY will show 'Fd' to indicate the Forced Defrost status.

When Forced Defrost is activated, the alarm will BEEP for 3 seconds.

After the first three seconds, during Forced Defrost Function, the alarm will BEEP continuously (0.5sec ON/ 0.5sec OFF).

7) Test Cancellation Mode.

7-1) When the Forced Defrost is activated, if DISPLAY PANEL is switched into the TEST MODE and TEST button is pressed one more time, Forced Defrost will be canceled and will return to the normal operation.

Or, all the TEST functions will be canceled by turning the MAIN POWER OFF and ON.

TROUBLESHOOTING

4-1-2. Self-diagnosis function

1) Self-diagnosis function with the initial POWER ON

- 1-1) When the refrigerator is powered on for the first time, MICOM internally operates a selfdiagnosis function to check the temperature sensors in a few seconds.
- 1-2) If a defective sensor is detected, "all the relevant DISPLAY LED"will blink at intervals of 0.5 sec. There will be no beep sound at this moment. (Refer to the self-diagnose CHECK LIST)
- 1-3) When the self-diagnostic error message is displayed due to a defective sensor, only the selfdiagnose button will be recognized and Display will not operate normally while temperature control will be controlled under the emergency operation.
- 1-4) When a self-diagnosis indicates an ERROR, either fix the defective sensor, or press the Freezer KEY and Control Lock KEY for 10 seconds to automatically deactivate the initial self-diagnose function.













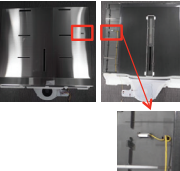

2) Self-diagnosis function during normal operation

- 2-1) If the Freezer KEY and Control Lock KEY are pressed for 10 seconds during normal operation, the Self-diagnosis function will be selected with a beep sound.
- 2-2) When initiating the self-diagnosis function, the entire LED will turn off. If there is an error, the indication of the error will be displayed for 60 seconds and then restored to the normal status whether the error is fixed or not. (Refer to the Self-Diagnosis Checklist below)
- 2-3) During the self-diagnosis, button input will not be recognized.

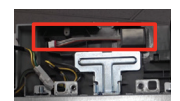

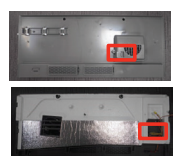



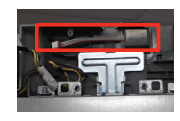

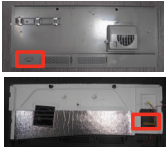

TROUBLESHOOTING







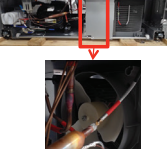



※ Self-diagnosis CHECK LIST

Error	Freezer Display	Fridge Display	Trouble contents	Diagnostic method	Picture
F-Sensor Error	1		C Slipped out Sensor Housing, Wire-Cut, Wire-Short, When the sensor pickup temp is over +50 °C or under -50 °C, Error occurs.	The voltage between Case Connector DC YEL1 #5 ↔ #6 should be within 4.5V~1.0V	 
R-Sensor Error	2			The voltage between Case Connector DC YEL2 #16 ↔ #17 should be within 4.5V~1.0V	 
F-Def Sensor Error	4			The voltage between Case Connector DC BLU1 #14 ↔ #15 should be within 4.5V~1.0V	 
R-Def Sensor Error	5			The voltage between Case Connector DC YEL2 #14 ↔ #15 should be within 4.5V~1.0V	 
Ambient Sensor Error	6			The voltage between HINGE CONNECTOR #2 ↔ #3 should be within 4.5V~1.0V	 
Pantry Sensor Error	7			The voltage between Case Connector DC BLU1 #16 ↔ #17 should be within 4.5V~1.0V	 
Standard Ice Maker Sensor Error	8			The voltage between Case Connector DC BLU1 #4 ↔ #5 should be within 4.5V~1.0V	 
Ambient-Humidity Sensor Error	13			The voltage between HINGE CONNECTOR #2 ↔ #4 should be within 4.5V~1.0V	 

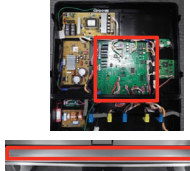
TROUBLESHOOTING

Error	Freezer Display	Fridge Display	Trouble contents	Diagnostic method	Picture	
R-Humidity Sensor Error	16	C	Slipped out Sensor Housing, Wire-Cut, Wire-Short, When the sensor pickup temp is over +50 °C or under -50 °C, Error occurs.	The voltage between Case Connector DC WHT #1 ↔ #2 should be within 4.5V~1.0V	 	
Cocktail Ice Maker Sensor Error	20			The voltage between Case Connector DC WHT #2 ↔ #3 should be within 4.5V~1.0V	 	
F-Fan Error	21			When the related Fan Motor operates, it occurs if the contact of the Feed Back Signal Wire is defective, the Motor Wire is slipped out or the Motor is defective	The voltage between Case Connector DC BLU1 #3 ↔ #4 should be within 7V~12V	 
R-Fan Error	22				The voltage between Case Connector DC YEL2 #19 ↔ #20 should be within 7V~12V	 
C-Fan Error	23				The voltage between Case Connector DC WHT #14 ↔ #15 should be within 7V~12V	 
F-Defrost Error	24				Separation of freezer compartment defrost heater housing part, contact error, disconnection, short circuit or temperature fuse error. Display error : the defrosting does not finish though freezer compartment defrost is heating continuously for more than 120 minutes.	After separating AC RED connector, resistance value between AC RED 4 ↔ 5 shall be 63(230) ohm ± 7%. (Resistance value is varied by input power) 0 ohm : heater short, ∞ ohm : wire/ bimetal open (Must power off)

TROUBLESHOOTING

Error	Freezer Display	Fridge Display	Trouble contents	Diagnostic method	Picture
Standard Ice Maker Function Error	26	C	When the Standard Ice Maker error occurs more than 3 times, the error will be displayed.	After changing the Ice Maker(R), plug the refrigerator power code again, and check the operation.	 
Standard Ice Maker Ice Pipe Heater Error	33		Display error when open error is detected by Heater : separation of Ice Pipe Heater housing part, contact error, disconnection, short circuit.	After separating DC YEL1 Connector, resistance value between DC YEL1 14↔17 wire shall be 135 ohm± 7%. 0 ohm : heater short, ∞ Ohm : wire.	 
Communication Error between Main ↔ Panel	41		When there is no communication between MICOM MAIN ↔ PANEL for more than 10 seconds, the MICOM MAIN ↔ PANEL Communication Error Window will show on the Display.	To check its defect, a Oscilloscope is needed. So, replace the MAIN PCB and check if the problem persists.	 
Communication Error between Main ↔ Inverter	44		Display 44Er in the panel : Inverter MICOM ↔ Main MICOM communication error.	Actually, If there is not a problem, it is desirable to replace Main and Inverter PCB With the oscilloscope after a cable problem confirming.	 
Communication Error between Main ↔ I/O Expander	46		Display 46Er in the panel : I/O Expander ↔ Main MICOM communication error.	It is desirable to replace Main PCB.	 
Pantry Fan Error	62		When the related Fan Motor operates, it occurs if the contact of the Feed Back Signal Wire is defective, the Motor Wire is slipped out or the Motor is defective	The voltage between Case Connector DC BLU1 #19 ↔ #20 should be within 7V~12V	 

TROUBLESHOOTING

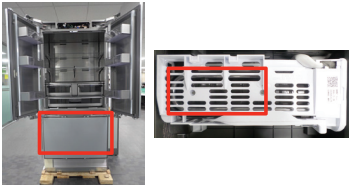
Error	Freezer Display	Fridge Display	Trouble contents	Diagnostic method	Picture
Abnormal High Temperature of Freezer	71	C	The error occurs when the Freezer temperature rises abnormally or when the Freezer Door remains open for a while while the unit's inside temperature is high.	When its Door remains open for an extended time or high temperature food is stored, close the Door or take out the hot food. Then, after a while, the error will disappear.	
Abnormal High Temperature of Fridge	72		The error occurs when the Fridge temperature rises abnormally or when the Fridge Door remains open for a while while the unit's inside temperature is high.		
Cocktail Ice Maker Function Error	74		When the Cocktail Ice Maker error occurs more than 3 times, the error will be displayed.	After changing the Ice Maker(R), plug the refrigerator power code again, and check the operation.	
Cocktail Ice Maker Ice Pipe Heater Error	75		Display error when open error is detected by Heater : separation of Ice Pipe Heater housing part, contact error, disconnection, short circuit.	After separating DC YEL1 Connector, resistance value between DC YEL1 14↔15 wire shall be 135 ohm± 7%. 0 ohm : heater short, ∞ Ohm : wire.	
Cabinet Rear Heater Error	78		Display error when open error is detected by Heater : separation of Ice Pipe Heater housing part, contact error, disconnection, short circuit.	After separating DC YEL1 Connector, resistance value between DC YEL1 14↔16 wire shall be 96 ohm± 7%. 0 ohm : heater short, ∞ Ohm : wire.	

TROUBLESHOOTING

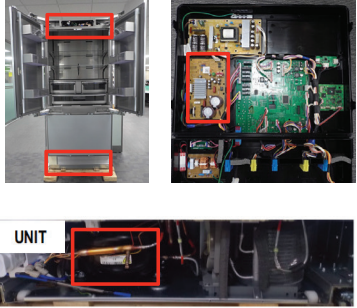
Error	Freezer Display	Fridge Display	Trouble contents	Diagnostic method	Picture
Comp Startup Failure	81	C	When the Comp Startup Failure is detected	1. Short between Comp. U/V/W (CN04) 2. Short between IPM PIN (#1~26) 3. IPM Operation Voltage Dropdown (Lower than DC13.5V) 4. Check Comp and Cycle	
Comp IPM Fault Error	82		When the Comp IPM Fault is detected		
Abnormal Current Pick-Up at Comp	83		When the Abnormal Current is pick-up at the Comp	1. Comp Connector Plugged Out (CN04) 2. R1 Defect or Assembly Defect 3. Check Comp and Cycle	
Comp Motor Restriction	84		When the Comp Motor Restriction is detected	1. When the Comp is restricted for more than 5 seconds 2. When the Comp runs at lower than 1000RPM for over 5 seconds 3. R1 Short 4. Severe fluctuation of Input Voltage 5. Check Comp and Cycle	
Comp Low Voltage	85		When the Low Voltage is detected at the Comp	1. Input AC Voltage 106V or lower 2. When R312 is short (DC Link Resistor)	
Comp High Voltage	86		When the High Voltage is detected at the Comp	1. Input AC Voltage 310V or higher 2. When R309, R310 or R311 is short (DC Link Resistor)	

TROUBLESHOOTING

4-1-3. Load Condition Display functions

- 1) When the Freezer KEY and Control Lock KEY are simultaneously pressed for about six seconds, PANEL DISPLAY will be ALL ON/OFF at an interval of 0.5 sec. By leaving the Fridge KEY and Control Lock KEY and pressing Fridge KEY at this moment, the display will switch modes to the Load Condition Display Function.
- 2) The Load Condition Display MODE indicates what kind of load is outputting the MICOM signal. However, it only indicates that the MICOM signal is outputted, not whether the load is actually operating. That is, even if it displays that a load is operating. The actual load might not work due to a defective RELAY on PCB, defective load, etc. (Needs to be checked)
- 3) Load Condition Display Function only continues for 30 seconds, and restores the normal mode automatically.



- 4) Relevant Display indication of Load Condition is as follows:

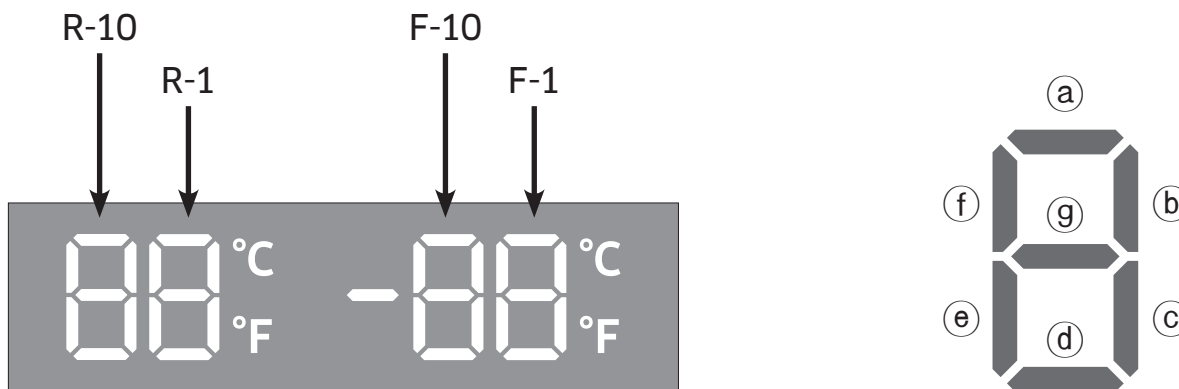

TROUBLESHOOTING

※ Load Mode CHECK LIST

Load Item	DISPLAY LED	Description
R-FAN HIGHEST	R-compartment first letter "a", "b"	Relevant LED will BLINK when R-FAN HIGHEST operates
R-FAN HIGH	R-compartment first letter "a"	Relevant LED will BLINK when R-FAN HIGH operates
R-FAN LOW	R-compartment first letter "b"	Relevant LED will BLINK when R-FAN LOW operates
Overload Condition	R-compartment first letter "e"	When ambient temperature is over 34°C(93.2°F), the relevant LED will BLINK
Low temperature condition	R-compartment first letter "f"	When ambient temperature is under 21°C(69.8°F), the relevant LED will BLINK
Normal condition	R-compartment first letter "e", "f"	When ambient temperature is between 22°C and 33°C, the relevant LED will BLINK
Exhibition Mode	R-compartment first letter "g"	The relevant LED will BLINK under exhibition mode
Standard Ice-Maker heater	R-compartment second letter "c"	The LED BLINK when the standard heater is activated
Standard Ice-Maker Full Ice Detection.	R-compartment second letter "d"	The LED BLINK when the standard Ice-maker is full
Cocktail Ice-Maker heater	R-compartment second letter "e"	The LED BLINK when the Cocktail Ice-maker heater is activated
Cocktail Ice-Maker Full Ice Detection	R-compartment second letter "f"	The LED BLINK when the Cocktail Ice-maker is full
COMP	F-compartment first letter "a"	The relevant LED will BLINK when the COMP operates
F-FAN HIGHEST	F-compartment first letter "b", "c"	The relevant LED will BLINK when F-FAN HIGHEST operates
F-FAN HIGH	F-compartment first letter "b"	The relevant LED will BLINK when F-FAN HIGH operates
F-FAN LOW	F-compartment first letter "c"	The relevant LED will BLINK when F-FAN LOW operates
F-compartment defrost heater	F-compartment first letter "d"	The relevant LED will BLINK when F-compartment defrost heater operates
C-FAN HIGHEST	F-compartment first letter "e", "f"	The relevant LED will BLINK when C-FAN HIGHEST operates
F-FAN HIGH	F-compartment first letter "e"	Relevant LED will BLINK when C-FAN HIGH operates
C-FAN LOW	F-compartment first letter "f"	The relevant LED will BLINK when C-FAN LOW operates
F Valve	F-compartment second letter "b"	The relevant LED will BLINK when the F-Valve is open

TROUBLESHOOTING

Load Item	DISPLAY LED	Description
F-Cooling Speed Valve	F-compartment second letter "c"	The relevant LED will BLINK when the F-missing Valve is open
R Valve	F-compartment second letter "f"	The LED will BLINK when the R Valve is open
FreshZone FAN	F-compartment second first "d"	The LED BLINK when the FreshZone FAN is ON
French Heater	F-compartment second letter "g"	The LED BLINK when the French Heater operates
Wifi condition	Wifi Icon	When not connected to a router or Internet: Off
		When connected to a router: BLINK
		When connected to the Internet LED ON

TROUBLESHOOTING

4-1-4. Operation Condition Restore Function For Blackout

- 1) If PANEL DISPLAY is reset by a momentary blackout, consumer's NON-SENSE CALL may occur. To prevent this, when the power is restored, either initialization or Operation Condition Restore will be initiated, depending on the interior temperature.
- 2) With the initial POWER ON, interior temperature and the defrost sensor temperature are checked. If either of the two temperatures are under about +10°C (50°F), judging there was a momentary blackout, functions related to the PANEL DISPLAY (interior temperature settings, Door Alarm, Power Cool, Power Freeze, Ice On/Off setting, etc.) are restored.
- 3) On initial POWER ON, if both interior temperature and defrost sensor temperature are over +10°C (50°F), judging there was a long-term blackout, PANEL DISPLAY is initialized. (Automatically sets -19°C for F-compartment and 3°C for R-compartment.)

4-1-5. Cooling Off Setting Function

- 1) If the Standard Ice, Water Filter Reset, and Override KEY are pressed for 5 seconds during the normal operation, the mode will be switched into the Cooling Off Mode. When switched into the Cooling Off Mode, temperature display panel will display "0 FF" sign.
- 2) When set to Cooling Off Mode DISPLAY and Fan Motor will operate normally. Only the Comp will not operate.
- 3) Cooling Off Mode will deactivate when Cooling Off KEY is pressed one more time.
- 4) If interior temperature rises over 65°C (149°F) when Cooling Off is set Cooling Off will deactivate, and restore Cooling Operation condition.



TROUBLESHOOTING

4-1-6. Display function of Communication error

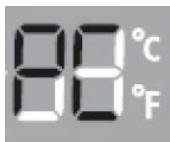

- 1) Display function when Panel ↔ MAIN MICOM communication has error.
 - 1-1) If there is no answer for 10 seconds after the panel micom received the requirement of communication, "PC" display on the panel PCB will be ON/OFF alternately until the communication error is canceled. (0.5 sec ALL ON, 0.5 sec ALL OFF alternately)
 - 1-2) "PC" display on the Panel Display will be ON/OFF alternately until the communication error is canceled. (0.5 sec ALL ON, 0.5 sec ALL OFF alternately)

4-1-7. Entering AP Mode and Smart Home Product Registration

- 1) Launch Samsung Smart Home app, go to the "device" section, and press "+" (add device) button, and select Refrigerator from the product list.
- 2) Follow the directions on the screen, input information of the wire/wireless router to be connected, and press "Next" button. (This step is to connect to the wire/wireless router to register the product, follow the app instructions.)
- 3) Press [Fridge] button for more than five seconds on the display. (After three seconds, Power Cool will be activated, and after two more seconds, Power cool will be deactivated and AP will be displayed.)
When "AP" is displayed on the temperature display panel, start Easy Connection
※ If Easy Connection does not proceed on the smartphone, please try this step again.
- 4) Easy Connection will automatically register the product. When product registration is finished, a refrigerator icon will appear on the app display. (If product registration fails, please try again from the first step.)
- 5) Select registered refrigerator icon.

4-1-8. MAC Address Display Mode

- 1) This function displays the MAC Address of the refrigerator Wi-Fi. The MAC address will be alternately displayed on the temperature display panel for a minute.
 - ① If the [Freezer] and [Fridge] buttons are pressed for more than 6 seconds, the Display will blink. Press [Freezer] button at this point, and it will initiate MAC Address Display Mode with a beep sound.
- 2) If MAC address is "11-22-33-44-55-66", it will display "--" → "11" → "22" → ... → "66" → "--" on the display panel for a minute. After a minute, MAC Address Display Function will be deactivated, and switched into the normal display mode.
 - ※ If the MAC address is invalid, or a Wi-Fi module is not connected, "--" will be displayed on the freezer compartment display panel for a minute.

When "AP" is displayed on the temperature display panel, start Easy Connection

- ※ If Easy Connection does not proceed on the smartphone, please try this step again.
- 4) Easy Connection will automatically register the product. When product registration is finished, a refrigerator icon will appear on the app display. (If product registration fails, please try again from the first step.)
 - 5) Select registered refrigerator icon.

TROUBLESHOOTING

4-1-9. Option Setting Function

- 1) When the Fridge, FreshZone, and Control Lock keys are pressed simultaneously for 12 seconds, it operates in Option setting mode.
- If there is no KEY input for 20 seconds in Option Setting Mode, it will switch into the normal DISPLAY.



Option Mode & Key operation Instructions



1. Displays selected Option number.
2. Displays the set value of the selected Option.
3. Increase Option number by one level.
4. Decrease the Option number by one level.
5. Increase Option setting value by one level.
6. Decrease Option setting value by one level.

TROUBLESHOOTING

- When the DISPLAY is switched into the Option Setting MODE every LED except temperature DISPLAY and KEY DISPLAY will be OFF as below.



- 1) For example, if you want to SHIFT the reference temperature of F-compartment to -2°C (-4°F) by changing the operating option, follow the below instructions.
This function changes the reference temperature. If F-compartment reference temperature is -21°C (-5.8°F), and lowered by -2°C (-4°F) by the option, the reference temperature will be controlled at -23°C (-9.4°F). That is, if you change the temperature setting, even if -21°C (-5.8°F) is set on the panel, The appliance will internally be operated at -23°C (-9.4°F).
Therefore, it means that the reference temperature is controlled -2°C (-4°F) lower than the set temperature displayed on the panel.

NOTE Fundamentally, Every data of the option function is cleared during the shipping process. In other words, every setting value is "0" during the shipping process. However, as some values may change for quality improvement during mass production, Always check quality information, and other related documents.

TROUBLESHOOTING

2) When switched into the option mode, DISPLAY will show "0" for OPTION numbers and setting values. (Every setting value is supposed to be set to "0" during the shipping process, but the basic setting values may have changed for quality improvement during mass production.)



Press number 3 or 4 buttons to set the desired option number.

1) For example, if you want to SHIFT the reference temperature of F-compartment, use number 3 or 4 button to set the option number to 0 as shown below. At this point, if you want to shift -2°C(-4°F), press the number 5 or 6 button to set the value of the Freezer Display to '4'.



Setting value	Option Value
Freezer Temp Display Panel Set Value	
0	0.0°C
1	-0.5°C
2	-1.0°C
3	-1.5°C
4	-2.0°C
5	-2.5°C
6	-3.0°C
7	-3.5°C
8	+0.5°C
9	+1.0°C
10	+1.5°C
11	+2.0°C
12	+2.5°C
13	+3.0°C
14	+3.5°C
15	+4.0°C

TROUBLESHOOTING

2) For example, if you want to SHIFT the reference temperature of R-compartment, use number 3 or 4 button to set the option number to 1 as shown below. At this point, if you want to shift +1.5°C, press the number 5 or 6 button to set the value of the Freezer Display to '10'.



Setting value	Option Value
Freezer Temp Display Panel Set Value	
0	0.0°C
1	-0.5°C
2	-1.0°C
3	-1.5°C
4	-2.0°C
5	-2.5°C
6	-3.0°C
7	-3.5°C
8	+0.5°C
9	+1.0°C
10	+1.5°C
11	+2.0°C
12	+2.5°C
13	+3.0°C
14	+3.5°C
15	+4.0°C

TROUBLESHOOTING

3) For example, if you want to adjust the Standard Ice Maker's water supply rate, use number 3 or 4 button to set the option number to 2 as shown below. At this point, if you want to set the water supply to 110cc, press the number 5 or 6 button to set the value of the Freezer Display to '1'.



Setting value	Option Value
Freezer Temp Display Panel Set Value	
0	100cc
1	110cc

TROUBLESHOOTING

- 4) For example, if you want to adjust Standard Ice Maker's idle time of ice ejection, use number 3 or 4 button to set the option number to 3 as shown below. At this point, if you want to set the idle time to 55 minutes, press the number 5 or 6 button to set the value of the Freezer Display to '4'.



Setting value	Option Value
Freezer Temp Display Panel Set Value	
0	60min
1	47min
2	45min
3	53min
4	55min
5	57min
6	65min
7	70min
8	50min
9	50min
10	50min
11	50min
12	50min
13	50min
14	50min
15	50min

TROUBLESHOOTING

5) For example, if you want to adjust Standard Ice Maker's ice ejecting temperature, use number 3 or 4 button to set the option number to 4 as shown below. At this point, if you want to set the temperature to -8.0°C, press the number 5 or 6 button to set the value of the Freezer Display to '3'.



Setting value	Option Value
Freezer Temp Display Panel Set Value	
0	-7.5°C
1	-7.0°C
2	-6.5°C
3	-8.0°C
4	-8.5°C
5	-9.0°C
6	-9.5°C
7	-10.0°C

TROUBLESHOOTING

6) For example, if you want to adjust Sub Heater's driving rate, use number 3 or 4 button to set the option number to 19 as shown below. At this point, if you want to add 20% more on the current driving rate, press the number 5 or 6 button to set the value of the Freezer Display to '1'.



Setting value	Option Value
Freezer Temp Display Panel Set Value	
0	Keep the current control status
1	add 20 percent on the current control status (maximum 100 %)

TROUBLESHOOTING

7) For example, if you want to SHIFT the reference temperature of FreshZone-compartment, use number 3 or 4 button to set the option number to 20 as shown below. At this point, if you want to shift -1.5°C, press the number 5 or 6 button to set the value of the Freezer Display to '3'.



Setting value	Option Value
Freezer Temp Display Panel Set Value	
0	0.0°C
1	-0.5°C
2	-1.0°C
3	-1.5°C
4	-2.0°C
5	+0.5°C
6	+1.0°C
7	+1.5°C

TROUBLESHOOTING

8) For example, if you want to adjust Cocktail Ice Maker's water supply, use number 3 or 4 button to set the option number to 32 as shown below. At this point, if you want to set the water supply to 140cc, press the number 5 or 6 button to set the value of the Freezer Display to '1'.



Setting value	Option Value
Freezer Temp Display Panel Set Value	
0	130cc
1	140cc

TROUBLESHOOTING

9) For example, if you want to adjust the Cocktail Ice Maker's idle time of ice ejection, use number 3 or 4 button to set the option number to 33 as shown below. At this point, if you want to set the idle time to 75 minutes, press the number 5 or 6 button to set the value of the Freezer Display to '4'.



Setting value	Option Value
Freezer Temp Display Panel Set Value	
0	80min
1	67min
2	65min
3	73min
4	75min
5	77min
6	85min
7	90min
8	70min
9	70min
10	70min
11	70min
12	70min
13	70min
14	70min
15	70min

TROUBLESHOOTING

10) For example, if you want to adjust Cocktail Ice Maker's ice ejection temperature, use number 3 or 4 button to set the option number to 35 as shown below. At this point, if you want to set the temperature on -8.0°C , press the number 5 or 6 button to set the value of the Freezer Display to '3'.



Setting value	Option Value
0	-7.5°C
1	-7.0°C
2	-6.5°C
3	-8.0°C
4	-8.5°C
5	-9.0°C
6	-9.5°C
7	-10.0°C

TROUBLESHOOTING

4-2) Diagnostic method according to the trouble symptom (Flow Chart)

DATA1.Temperature table

Resistance value and MICOM port voltage of sensor according to the temperature

SENSOR CHIP : based on PX41C, PX41C, 502AT/ 103**(ICE MAKER SENSOR(MOLD)/FULL UP, 20Kohm (Actual measurement = value of the table below X 2)

°C	°F	Voltage	Resistance	°C	°F	Voltage	Resistance	°C	°F	Voltage	Resistance
-50	-58	4.694	153319	-5	23	3.107	16419	40	104	1.153	2997
-49	-56.2	4.677	144794	-4	24.8	3.057	15731	41	105.8	1.124	2899
-48	-54.4	4.659	136798	-3	26.6	3.006	15076	42	107.6	1.095	2805
-47	-52.6	4.641	129294	-2	28.4	2.955	14452	43	109.4	1.068	2714
-46	-50.8	4.622	122248	-1	30.2	2.904	13857	44	111.2	1.040	2627
-45	-49	4.602	115631	0	32	2.853	13290	45	113	1.014	2543
-44	-47.2	4.581	109413	1	33.8	2.802	12749	46	114.8	0.988	2462
-43	-45.4	4.560	103569	2	35.6	2.751	12233	47	116.6	0.963	2384
-42	-43.6	4.537	98073	3	37.4	2.700	11741	48	118.4	0.938	2309
-41	-41.8	4.514	92903	4	39.2	2.649	11271	49	120.2	0.914	2237
-40	-40	4.490	88037	5	41	2.599	10823	50	122	0.891	2167
-39	-38.2	4.465	83456	6	42.8	2.548	10395	51	123.8	0.868	2100
-38	-36.4	4.439	79142	7	44.6	2.498	9986	52	125.6	0.846	2036
-37	-34.6	4.412	75077	8	46.4	2.449	9596	53	127.4	0.824	1973
-36	-32.8	4.385	71246	9	48.2	2.399	9223	54	129.2	0.803	1913
-35	-31	4.356	67634	10	50	2.350	8867	55	131	0.783	1855
-34	-29.2	4.326	64227	11	51.8	2.301	8526	56	132.8	0.762	1799
-33	-27.4	4.296	61012	12	53.6	2.253	8200	57	134.6	0.743	1745
-32	-25.6	4.264	57977	13	55.4	2.205	7888	58	136.4	0.724	1693
-31	-23.8	4.232	55112	14	57.2	2.158	7590	59	138.2	0.706	1642
-30	-22	4.199	52406	15	59	2.111	7305	60	140	0.688	1594
-29	-20.2	4.165	49848	16	60.8	2.064	7032	61	141.8	0.670	1547
-28	-18.4	4.129	47431	17	62.6	2.019	6771	62	143.6	0.653	1502
-27	-16.6	4.093	45146	18	64.4	1.974	6521	63	145.4	0.636	1458
-26	-14.8	4.056	42984	19	66.2	1.929	6281	64	147.2	0.620	1416
-25	-13	4.018	40938	20	68	1.885	6052	65	149	0.604	1375
-24	-11.2	3.980	39002	21	69.8	1.842	5832	66	150.8	0.589	1335
-23	-9.4	3.940	37169	22	71.6	1.799	5621	67	152.6	0.574	1297
-22	-7.6	3.899	35433	23	73.4	1.757	5419	68	154.4	0.560	1260
-21	-5.8	3.858	33788	24	75.2	1.716	5225	69	156.2	0.546	1225
-20	-4	3.816	32230	25	77	1.675	5039	70	158	0.532	1190
-19	-2.2	3.773	30752	26	78.8	1.636	4861	71	159.8	0.519	1157
-18	-0.4	3.729	29350	27	80.6	1.596	4690	72	161.6	0.506	1125
-17	1.4	3.685	28021	28	82.4	1.558	4526	73	163.4	0.493	1093
-16	3.2	3.640	26760	29	84.2	1.520	4369	74	165.2	0.481	1063
-15	5	3.594	25562	30	86	1.483	4218	75	167	0.469	1034
-14	6.8	3.548	24425	31	87.8	1.447	4072	76	168.8	0.457	1006
-13	8.6	3.501	23345	32	89.6	1.412	3933	77	170.6	0.446	978
-12	10.4	3.453	22320	33	91.4	1.377	3799	78	172.4	0.435	952
-11	12.2	3.405	21345	34	93.2	1.343	3670	79	174.2	0.424	926
-10	14	3.356	20418	35	95	1.309	3547	80	176	0.414	902
-9	15.8	3.307	19537	36	96.8	1.277	3428	81	177.8	0.404	877
-8	17.6	3.258	18698	37	98.6	1.253	3344	82	179.6	0.394	854
-7	19.4	3.208	17901	38	100.4	1.213	3204	83	181.4	0.384	832
-6	21.2	3.158	17142	39	102.2	1.183	3098	84	183.2	0.375	810

TROUBLESHOOTING

DATA2. Humidity Sensor table

- Voltage output table @23°..., 5Vdc --- HTG3515CH/HTG3535CH

RH(Temperature compensate) = RH (Relative Humidity) + (Temp(°C) °c 23°C) x 0.05

RH(%)	Output (mV)	A/D (10 bit)	A/D (12 bit)	RH(%)	Output (mV)	A/D (10 bit)	A/D (12 bit)	RH(%)	Output (mV)	A/D (10 bit)	A/D (12 bit)
0	909	186	744	46	2246	460	1839	92	3452	706	2827
1	943	193	772	47	2272	465	1861	93	3478	712	2848
2	977	200	800	48	2298	470	1882	94	3504	717	2870
3	1010	207	827	49	2324	475	1903	95	3530	722	2891
4	1043	213	854	50	2350	481	1925	96	3566	730	2920
5	1076	220	881	51	2376	486	1946	97	3595	735	2944
6	1109	227	908	52	2402	491	1967	98	3624	741	2968
7	1141	233	935	53	2428	497	1989	99	3653	747	2992
8	1173	240	961	54	2454	502	2010	100	3683	754	3016
9	1205	247	987	55	2480	507	2031				
10	1235	253	1011	56	2505	513	2052				
11	1266	259	1037	57	2530	518	2072				
12	1297	265	1062	58	2555	523	2093				
13	1328	272	1088	59	2580	528	2113				
14	1359	278	1113	60	2605	533	2133				
15	1390	284	1138	61	2630	538	2154				
16	1420	291	1163	62	2655	543	2174				
17	1450	297	1188	63	2680	548	2195				
18	1480	303	1212	64	2705	553	2215				
19	1510	309	1237	65	2730	559	2236				
20	1540	315	1261	66	2756	564	2257				
21	1569	321	1285	67	2782	569	2278				
22	1598	327	1309	68	2808	575	2300				
23	1627	333	1333	69	2834	580	2321				
24	1656	339	1356	70	2860	585	2342				
25	1685	345	1380	71	2886	590	2364				
26	1713	350	1403	72	2912	596	2385				
27	1741	356	1426	73	2938	601	2406				
28	1769	362	1449	74	2964	606	2428				
29	1797	368	1472	75	2990	612	2449				
30	1825	373	1495	76	3017	617	2471				
31	1852	379	1517	77	3044	623	2493				
32	1879	384	1539	78	3071	628	2515				
33	1906	390	1561	79	3098	634	2537				
34	1933	395	1583	80	3125	639	2559				
35	1960	401	1605	81	3152	645	2581				
36	1986	406	1627	82	3179	650	2604				
37	2012	412	1648	83	3206	656	2626				
38	2038	417	1669	84	3233	661	2648				
39	2064	422	1690	85	3260	667	2670				
40	2090	428	1712	86	3288	673	2693				
41	2116	433	1733	87	3316	678	2716				
42	2142	438	1754	88	3344	684	2739				
43	2168	444	1776	89	3372	690	2762				
44	2194	449	1797	90	3400	696	2785				
45	2220	454	1818	91	3426	701	2806				

TROUBLESHOOTING

4-3) Case Output Terminal

(The Main PCB and the Case Output Terminals are connected with wire connectors.)

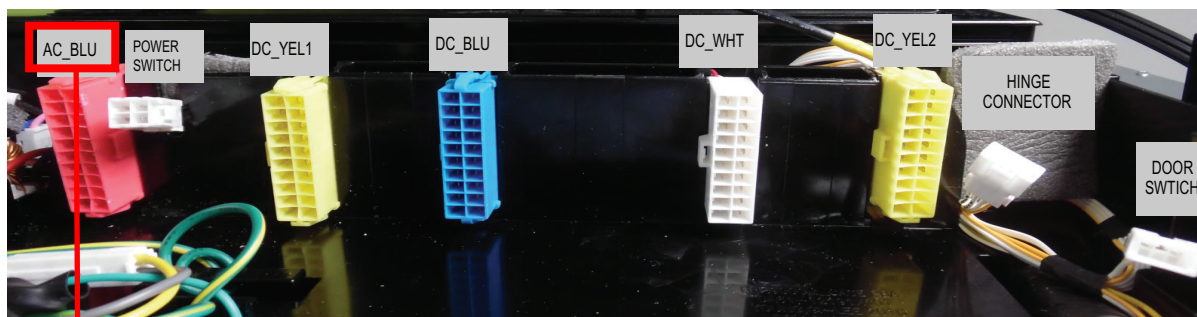

AC_RED

*Test the terminals on the PCB Case to check for voltage of operation related errors concerning BUILT-IN PJT. The terminal composition is shown in the diagram. If an error is found while testing

The above terminals and the housing connectors, check the inside of the PCB Case.
=>The following descriptions are based on the PCB Case.

Ref. PIN NUMBER

10	20
9	19
8	18
7	17
6	16
5	15
4	14
3	13
2	12
1	11

TROUBLESHOOTING

(PLATE FIXER HOUSING PIN MAPPING)

POWER SWITCH

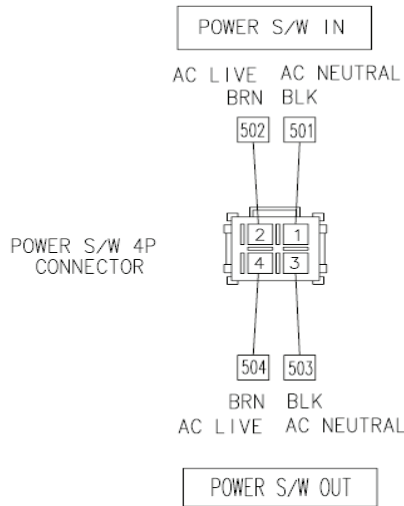

AC RED

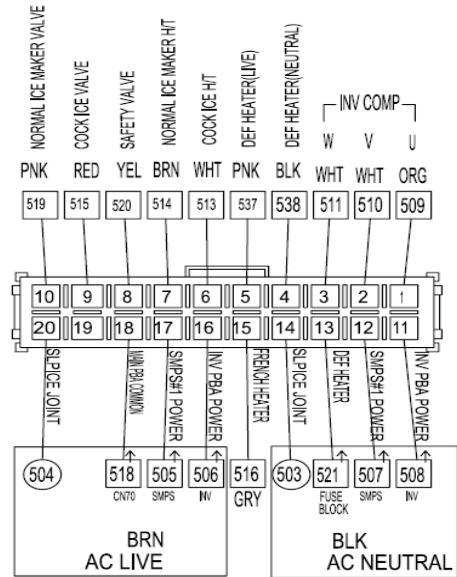

DC BLU

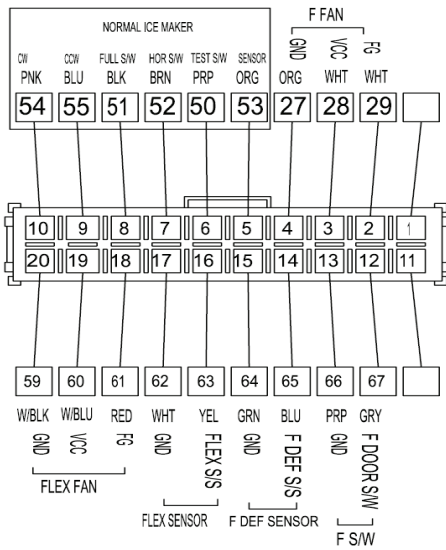

DC YEL1

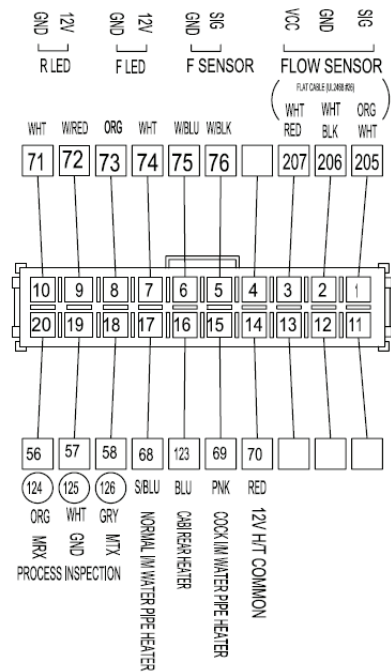

TROUBLESHOOTING

(PLATE FIXER HOUSING PIN MAPPING)

DC YEL2

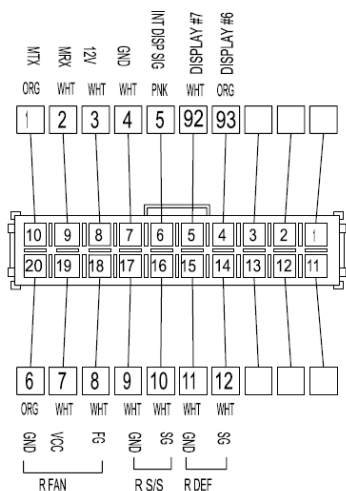

DC WHT

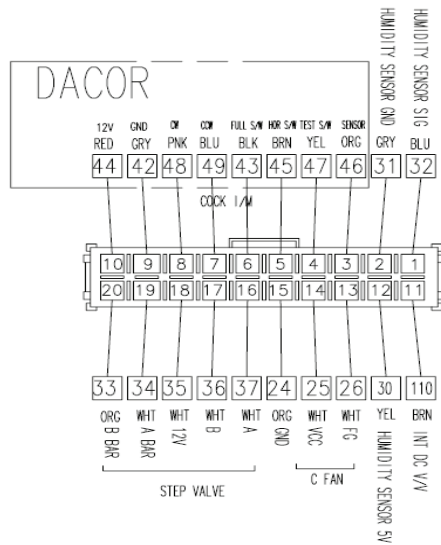

DOOR SWITCH

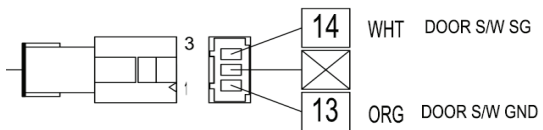

HINGE CONNECTOR

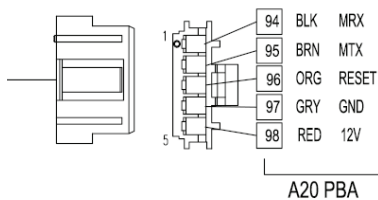
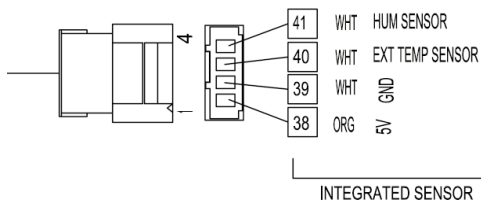

TROUBLESHOOTING

4-4) How to Enter the Test Mode

1) When there is no Power (SMPS PCB)

CAUTION There are AC input voltage running on Power switch connector. So, be cautious when repairing the unit or measuring values.

SMPS PCB CHECK Using Multimeter

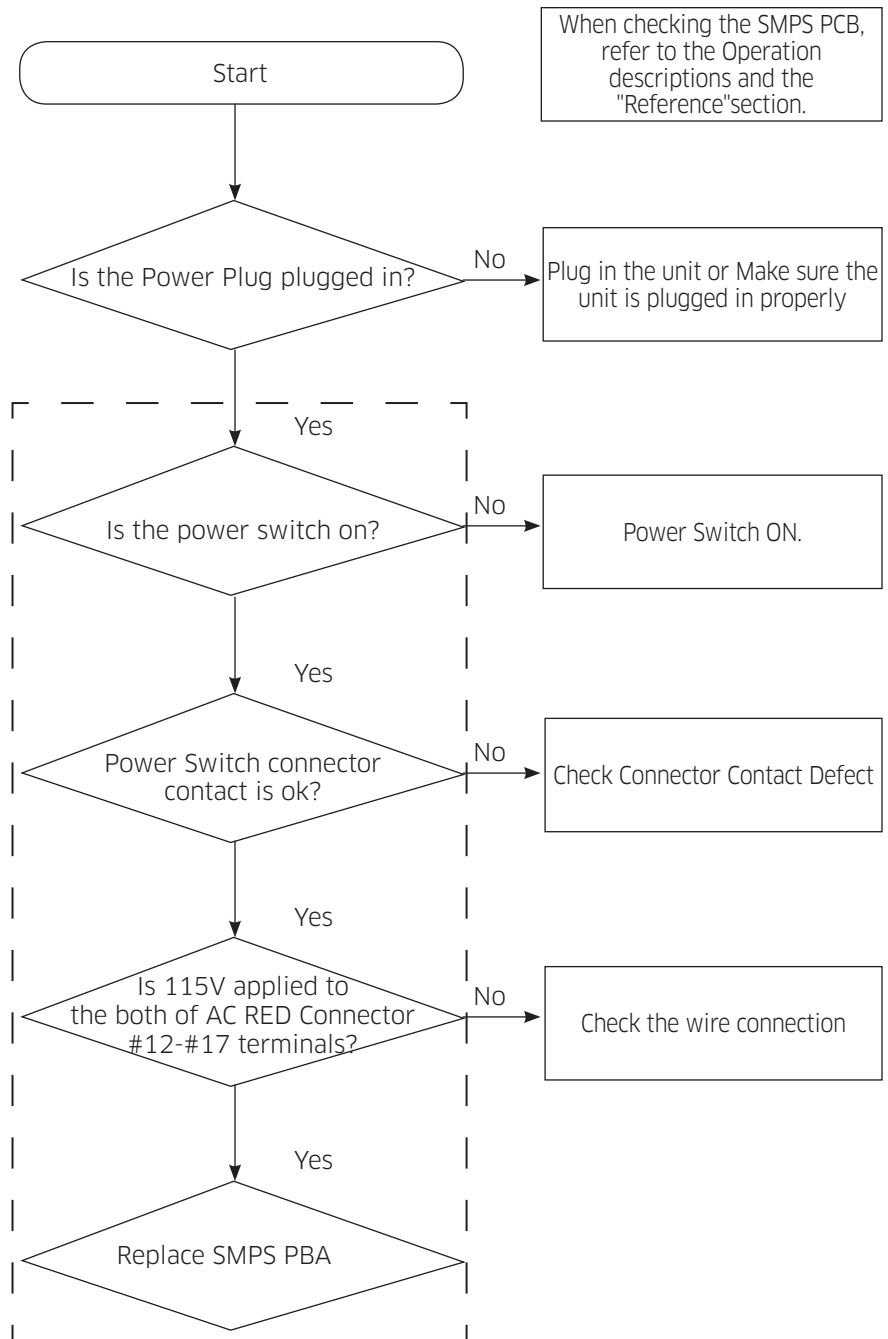
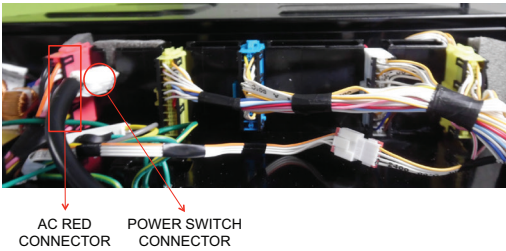

TROUBLESHOOTING

2) When the compressor does not operate (Inverter Comp)

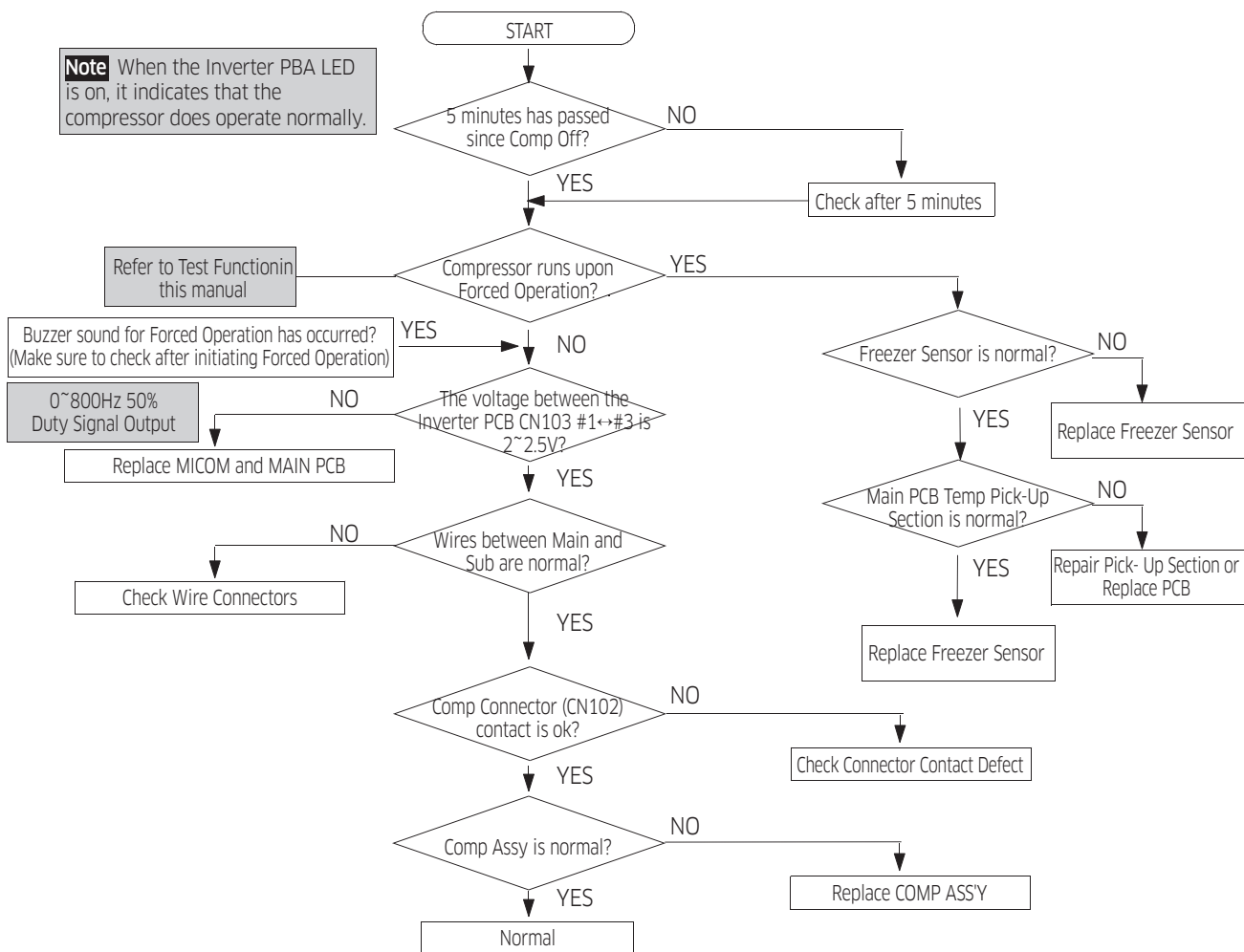







TROUBLESHOOTING

3) Troubleshooting based on LED Blinking Frequency

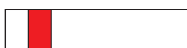
When failure is detected by the Inverter PCB, the Compressor will immediately stop if the Compressor is running and there will be a 5 minute standby. During the 5 minute standby, RPM signals will be ignored.

That is, even though the Inverter PCB receives the RPM signals, the Compressor does not work.

It blinks every second and there is 2 second off at the end of each cycle.

LED Blinking Frequency	Protecting Functions	Remarks
	Normal Operation	N/A
	Starting Failure	1. Check the COMP terminals short(U,V,W) 2. Check IPM Pins short of Inverter PBA 3. Check IPM operating Voltage(under DC 13.5V) 4. Other cases, check the COMP, cycle, etc.
	IPM Fault	1. Check COMP wire connections(U,V,W) 2. Check PCB Bottom side soldering state 3. Other cases, check the COMP, cycle, etc.
	Abnormal Current Detection	1. Check COMP wire connections(U,V,W) 2. Check PCB Bottom side soldering state 3. Other cases, check the COMP, cycle, etc.
	Motor Locked / Over RPM	1. Check PCB Bottom side soldering state. 2. Check Input voltage oscillation 3. Other cases, check the COMP, cycle, etc.
	Under Voltage	1. Check input voltage under AC 53V(Input Power AC110 ~ 127V) or AC 106V(Input Power AC220 ~ 240V) 2. Check PCB Bottom side soldering sate.
	Over Voltage	1. Check input voltage over AC 155V(Input Power AC110 ~ 127V) or AC 310V(Input Power AC220 ~ 240V) 2. Check PCB Bottom side soldering sate.

TROUBLESHOOTING

4) When Defrost does not work

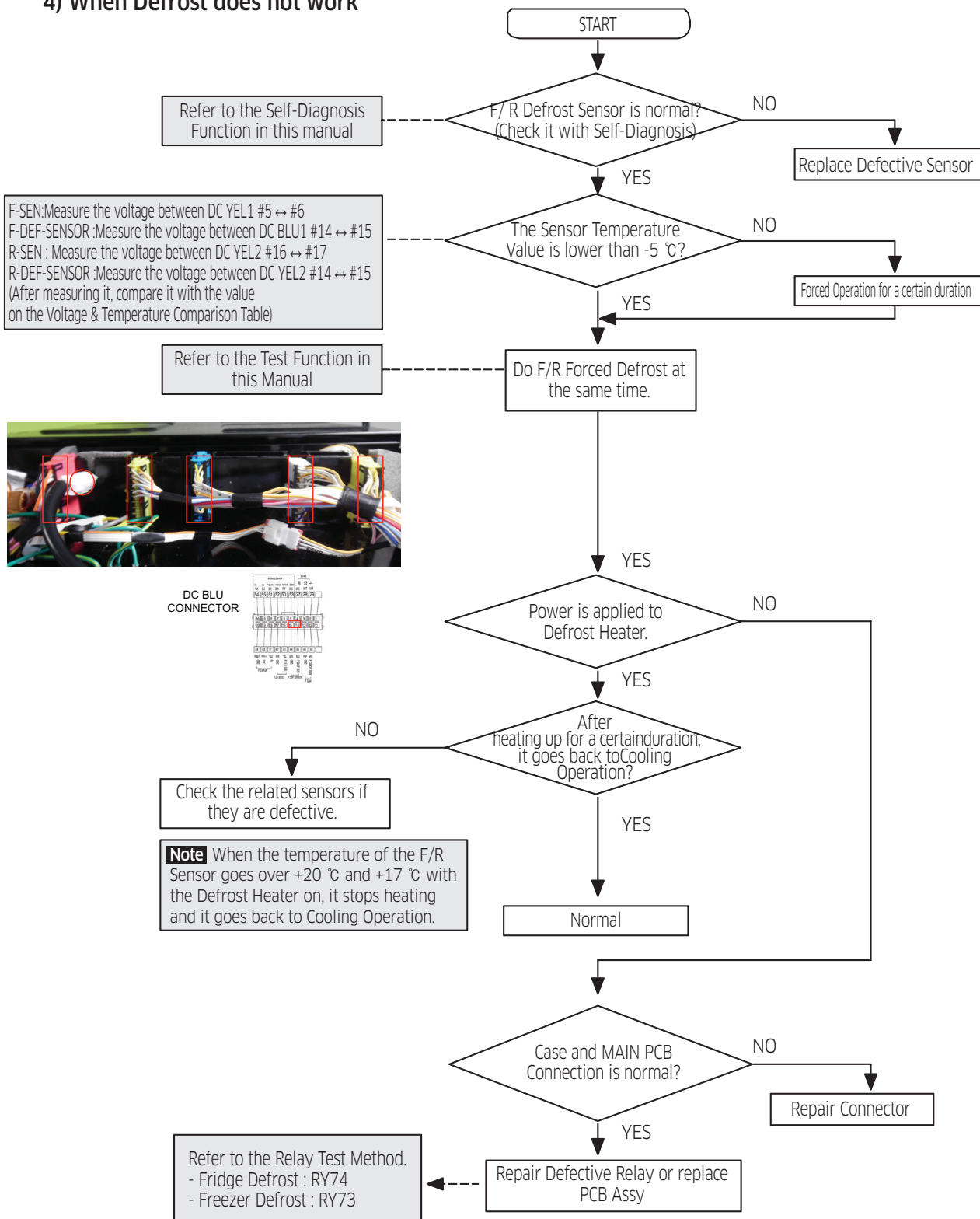

TROUBLESHOOTING

5) When there is Self-Diagnosis Error (with Defective Sensor)

- The error of sensor will be displayed on the front of display. when the error of sensor is detected at initial power ON, the appliance will not operated and the error message will be displayed.
- The appliance will not stop operating when the error of sensor is detected during operation of the appliance. But normal freezing might be not operated if the appliance is operated by the emergency operation mode. You would better to check the appliance according to the self-diagnosis of the manual.

- ① When R-Room Sensor error occurs (check the other sensors in the same procedure)
 -. Measure with PCB Case as a base

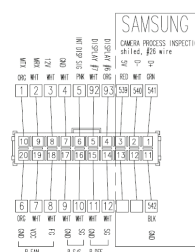
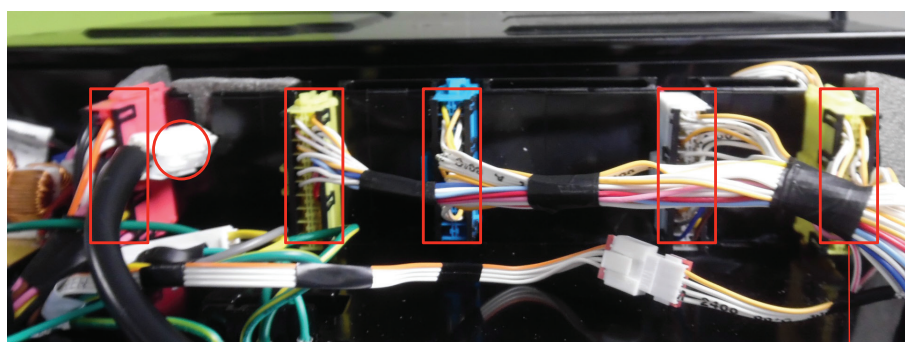
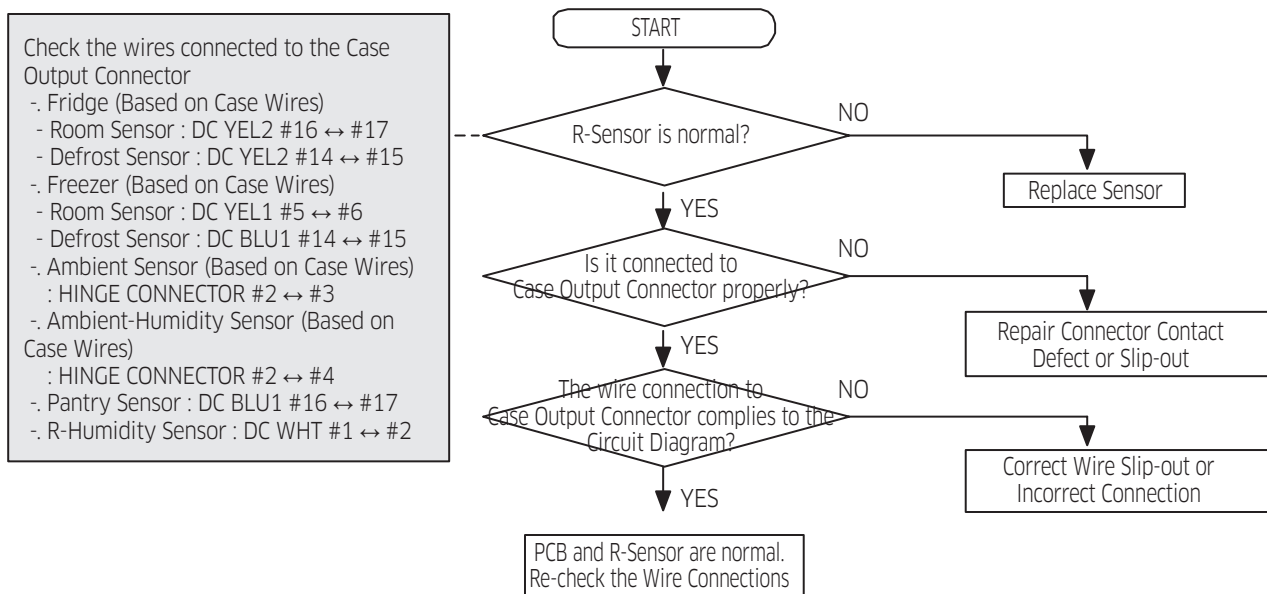

DC YEL 2 CONNECTOR

TROUBLESHOOTING

6) When the alarm sound will not turn off.

① When Door Open "Sound" keeps alarming

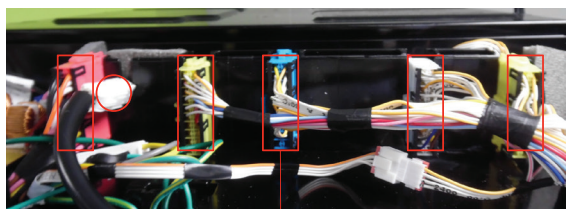

Freezer Door SW : DC BLUE CONNECTOR



Freezer Door : DC BLU1 Connector #12-#13
 Fridge Door : DOOR SWITCH #1-#3
 - Normal Voltage : Open 0V & Close 5V

When measuring the resistance of the Door S/W, check if it shifts $0\Omega \leftrightarrow \infty\Omega$ as turning on and off the Door S/W.

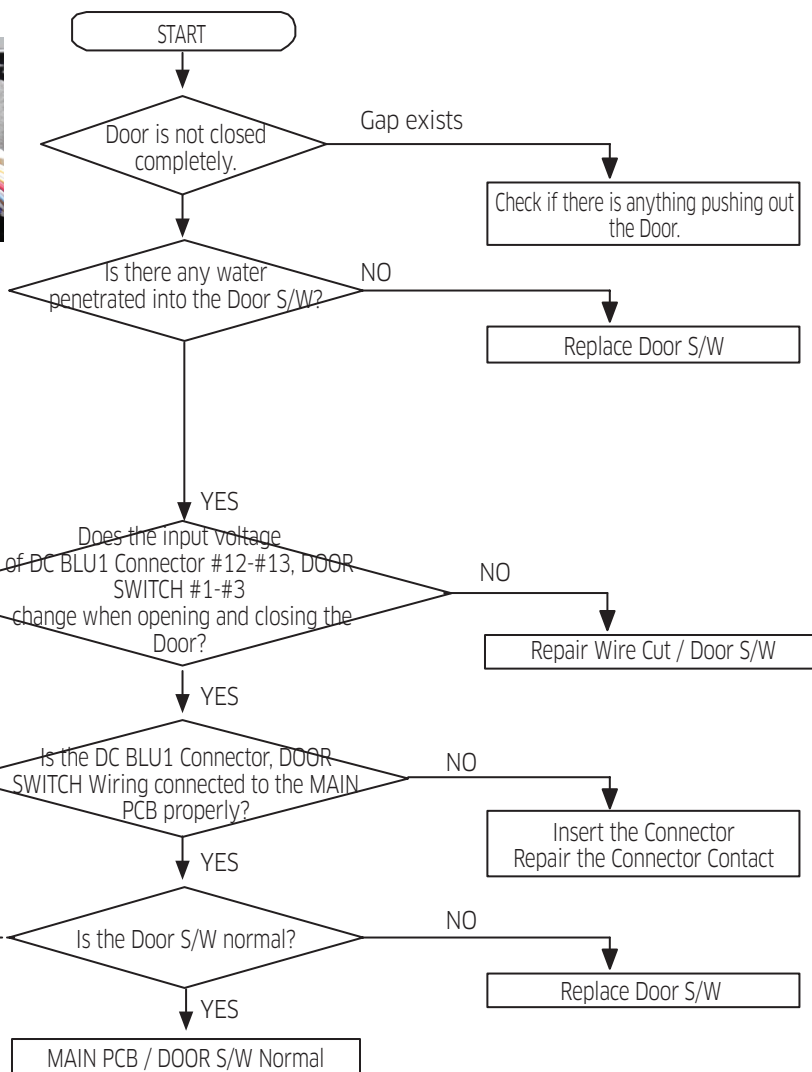

② When alarm sound "Beep" continues

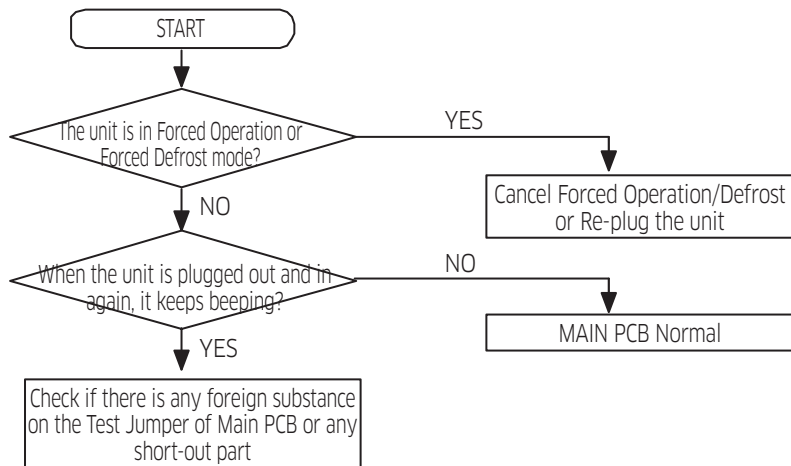

TROUBLESHOOTING

7) When the Display is defective or there is Communication Error

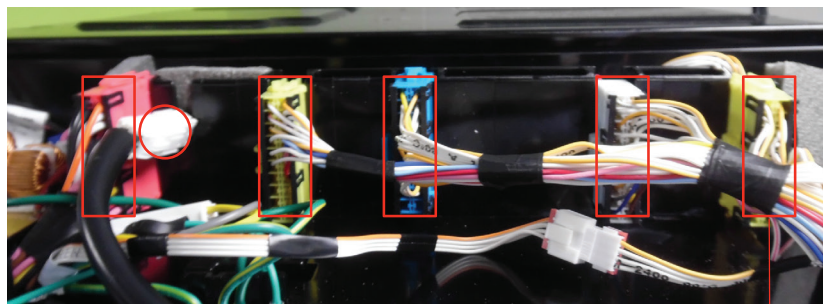
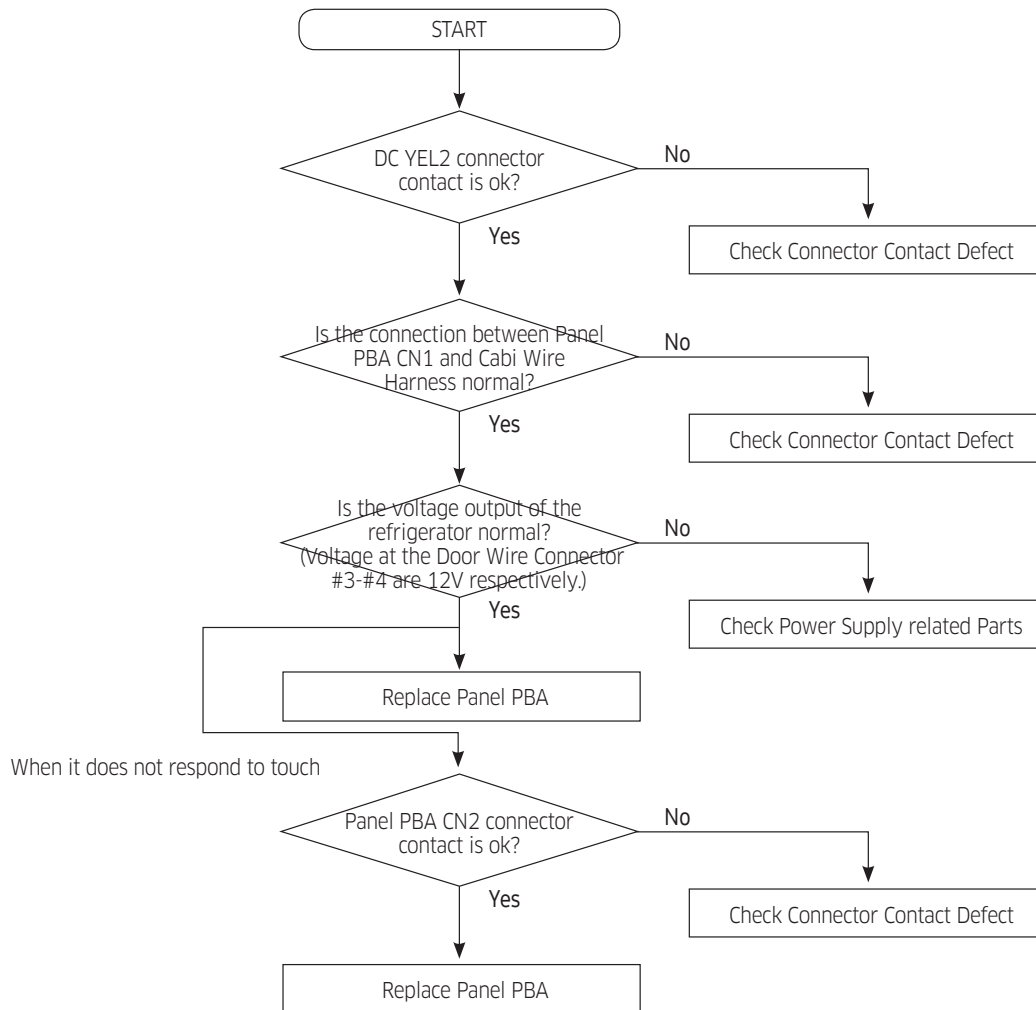

DC YEL 2 CONNECTOR

TROUBLESHOOTING

8) When Fan does not operate

- This refrigerator uses the BLDC Fan Motor. The BLDC Motor operates with DC 7~12V.
- Under Comp On conditions, the F-Fan operates generally. But, the F-Fan Motor may not work due to various conditions (such as the operating condition of Cool Select Pantry, etc) and when the ambient temperature is high or when you open and close the Door once, it operates after one minute delay. So, don't get misled by it. It is normal.
- Also, when the Fridge Door is open, the Freezer Fan Motor stops together with the Fridge Fan Motor (for the purpose of performance improvement).

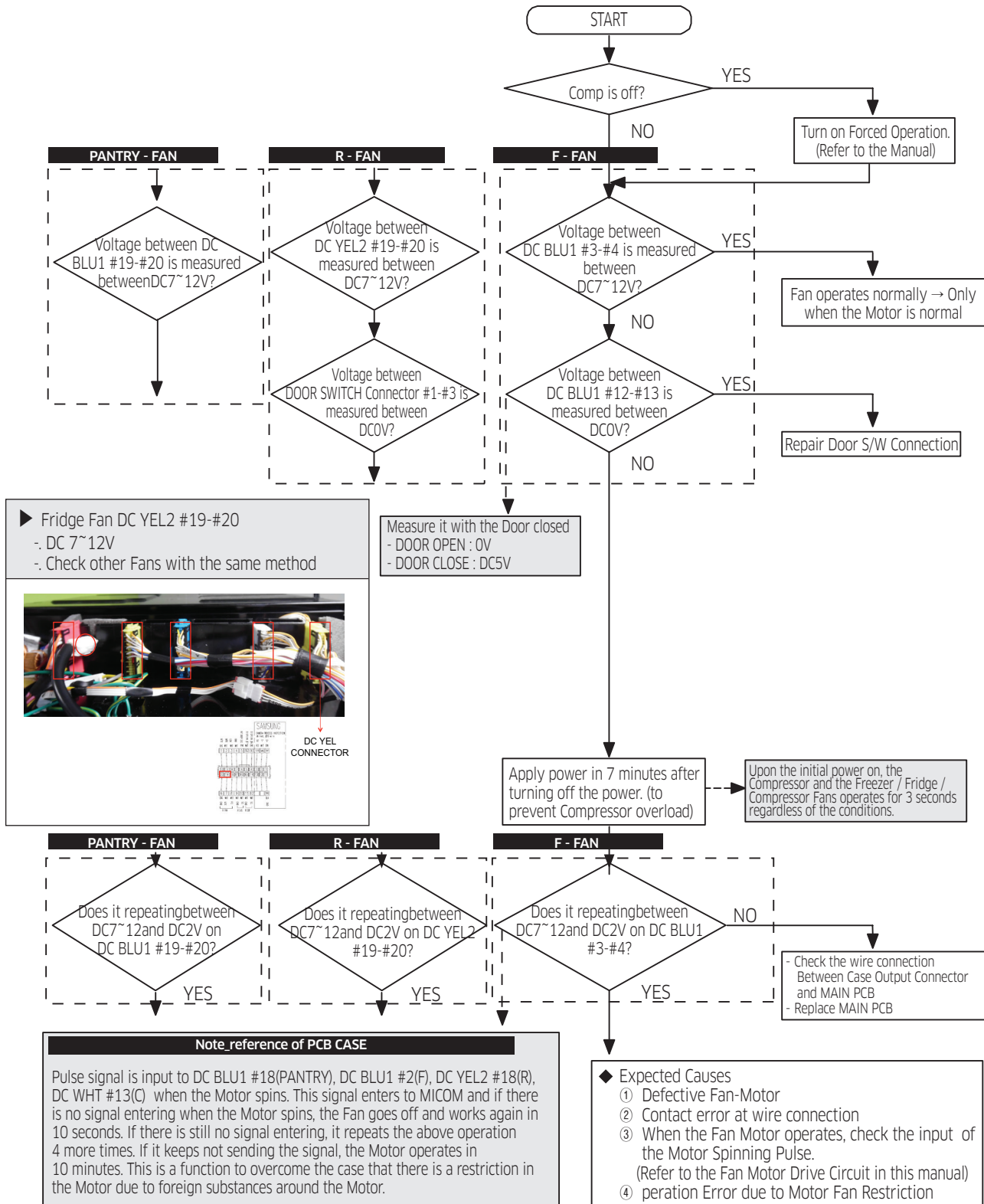

TROUBLESHOOTING

9) When the Freezer / Fridge Lamp does not light up

CAUTION

1. When replacing the Freezer Lamp, be sure to turn off the power to prevent electric shock.
2. LED lamps are used in the both of the Fridge and the Freezer compartments of this model.

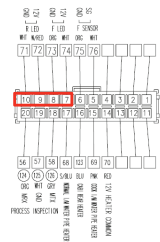
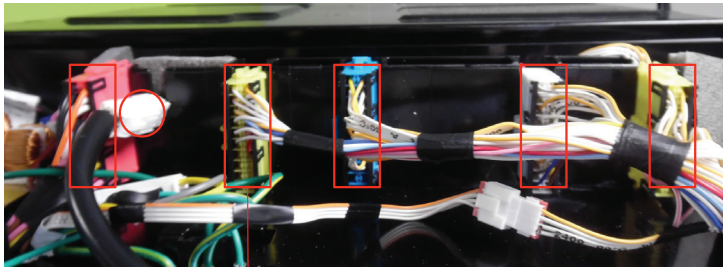
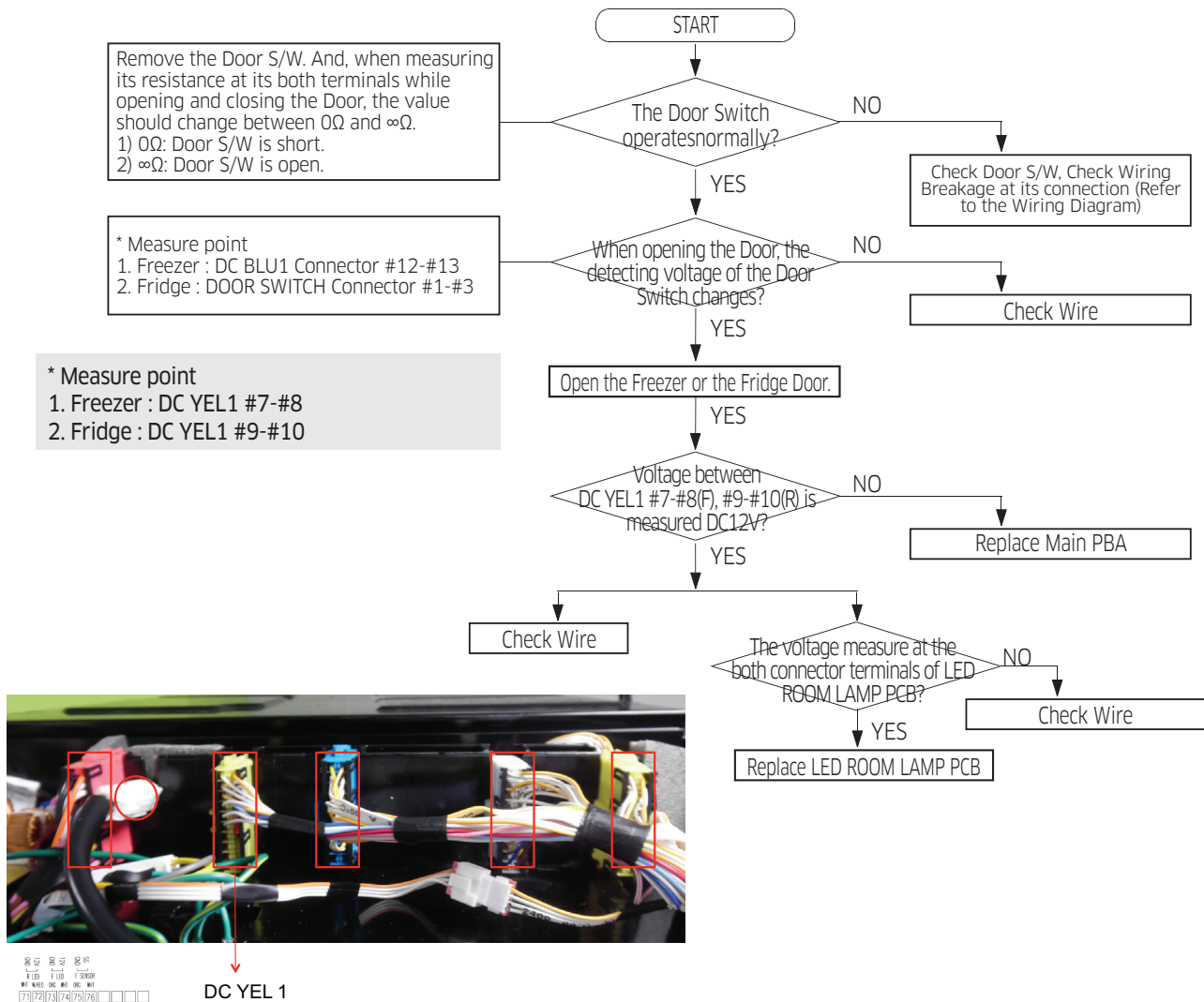

* Voltage Values by Door Status

Location Case Output Connector	Freezer	Fridge
	DC BLU1 Connector #12-#13	DOOR SWITCH
OPEN	0V	0V
CLOSE	5V	5V

TROUBLESHOOTING

10) When there is problem in the sound function

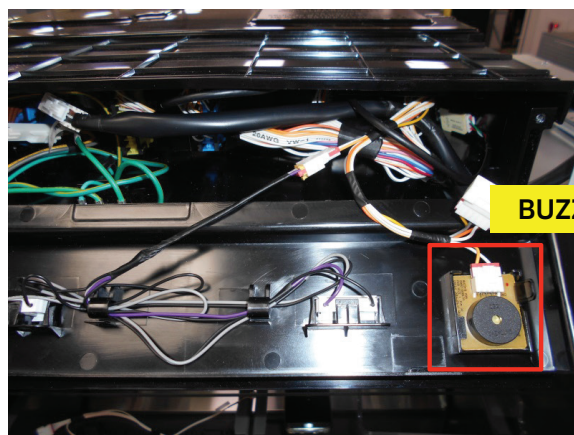
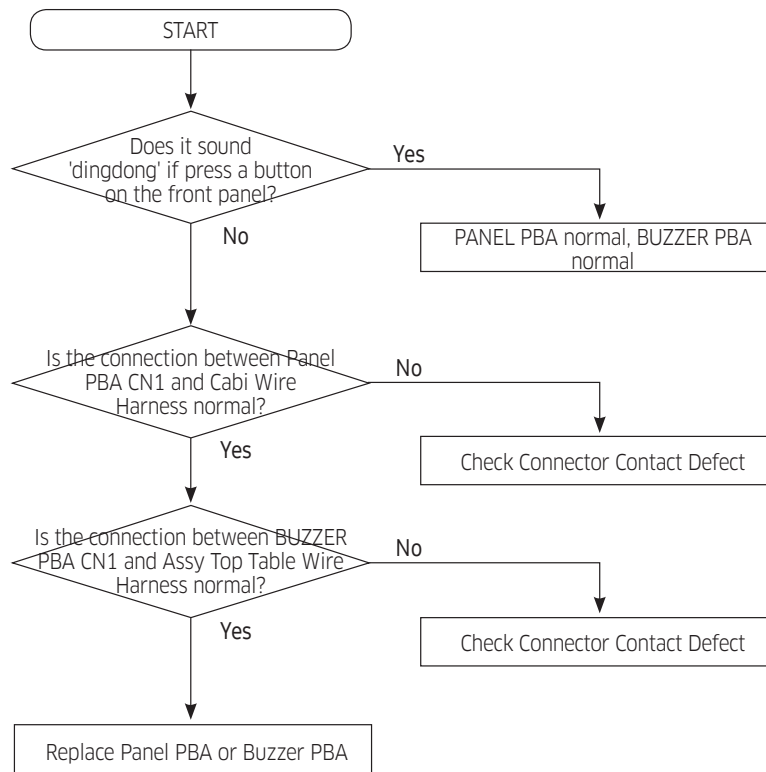

TROUBLESHOOTING

12) When the Water Valve does not work

Pre-checking

1. Water is directly supplied to the Water Valve. So, make sure to cut off the water before doing repairs.
2. There is electricity flowing in the wire. So, take extra care not to get electric shock.

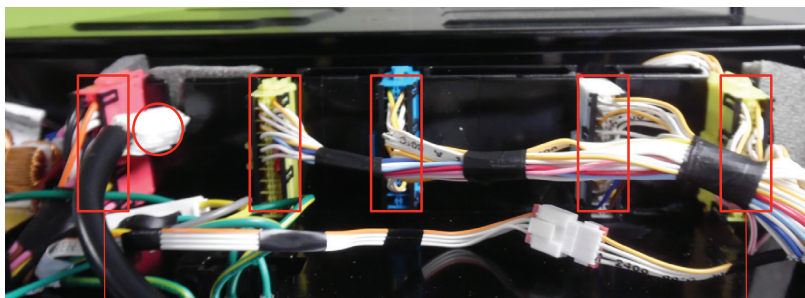
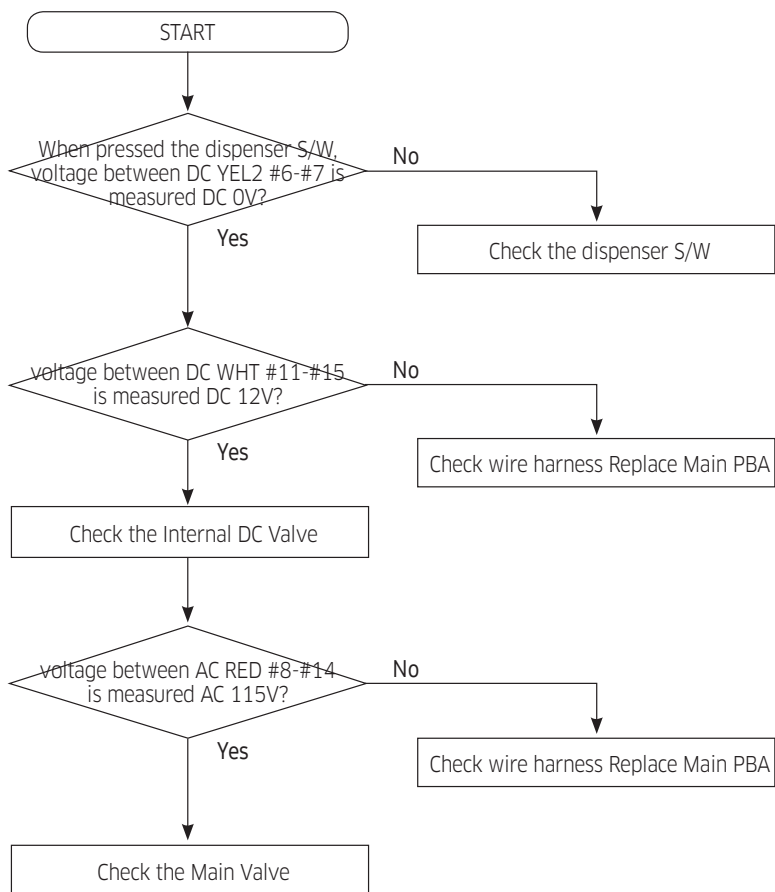

AC RED CONNECTOR

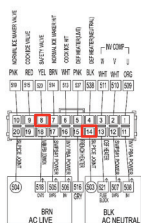

DC YEL CONNECTOR

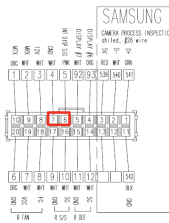

TROUBLESHOOTING

13) When ICE MAKER(Cocktail, Standard) does not operate

1. Water will be automatically supplied to the Ice Maker depending on temperature & time conditions, and ice will be produced to dispense.
2. Power is applied to one end of the wires. So, make sure to refer to its Exploded View whenever doing the disassembly.
3. The operation of the Ice Maker shall be done after pressing the Ice Maker Test Button.
(Fridge Ice Maker) It is not possible to check when the power is off.
4. Since both of the PCB and the Ice Maker are located at the front and the back each other, make sure to have two people check them.
5. It may cause burn when the Ice Maker Heater heats up. So, please take an extra caution.
6. The Ice Maker has a counter-clockwise rotation function. So, its counter-clockwise rotation is normal.

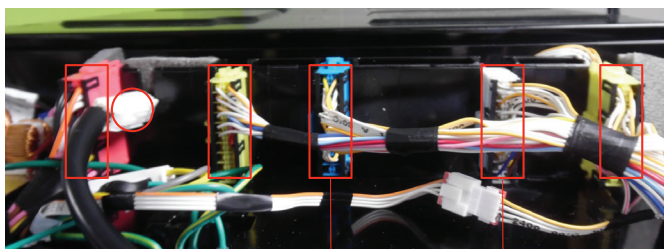
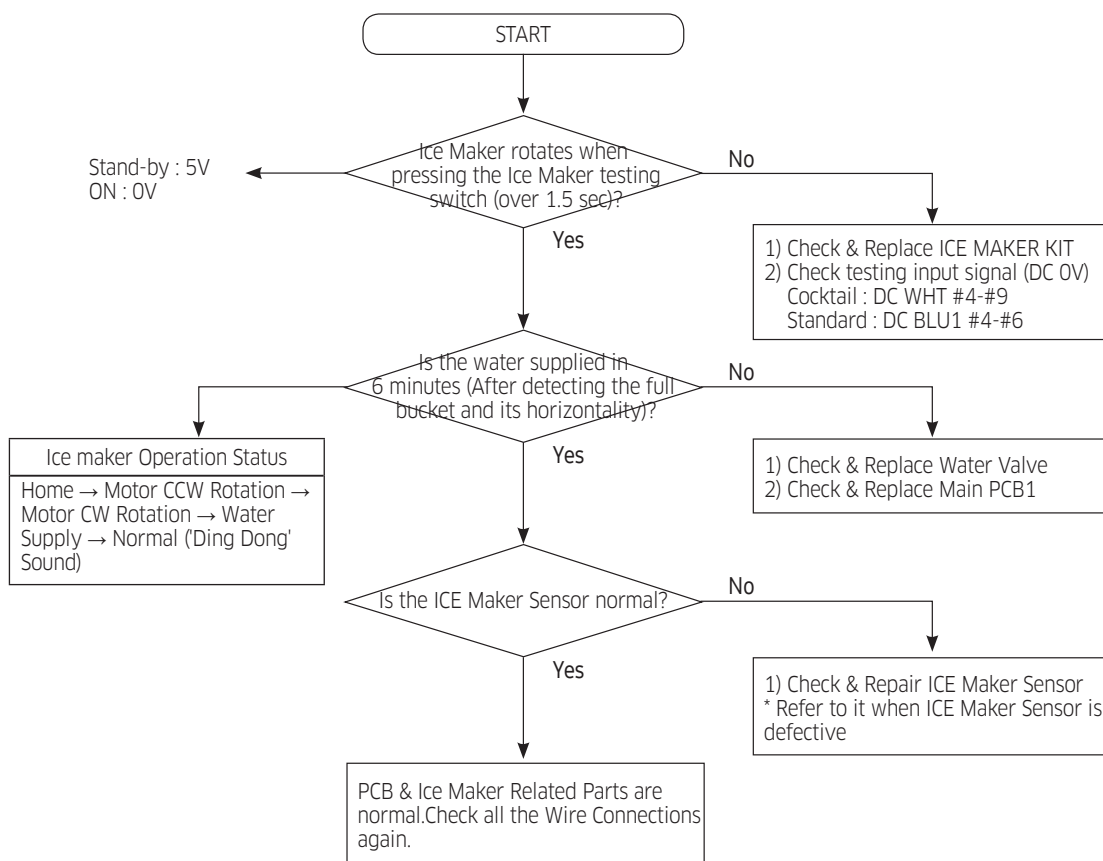

DC BLU CONNECTOR

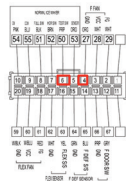

DC WHT CONNECTOR

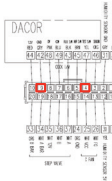

TROUBLESHOOTING

14) When Wi-Fi does not operate properly

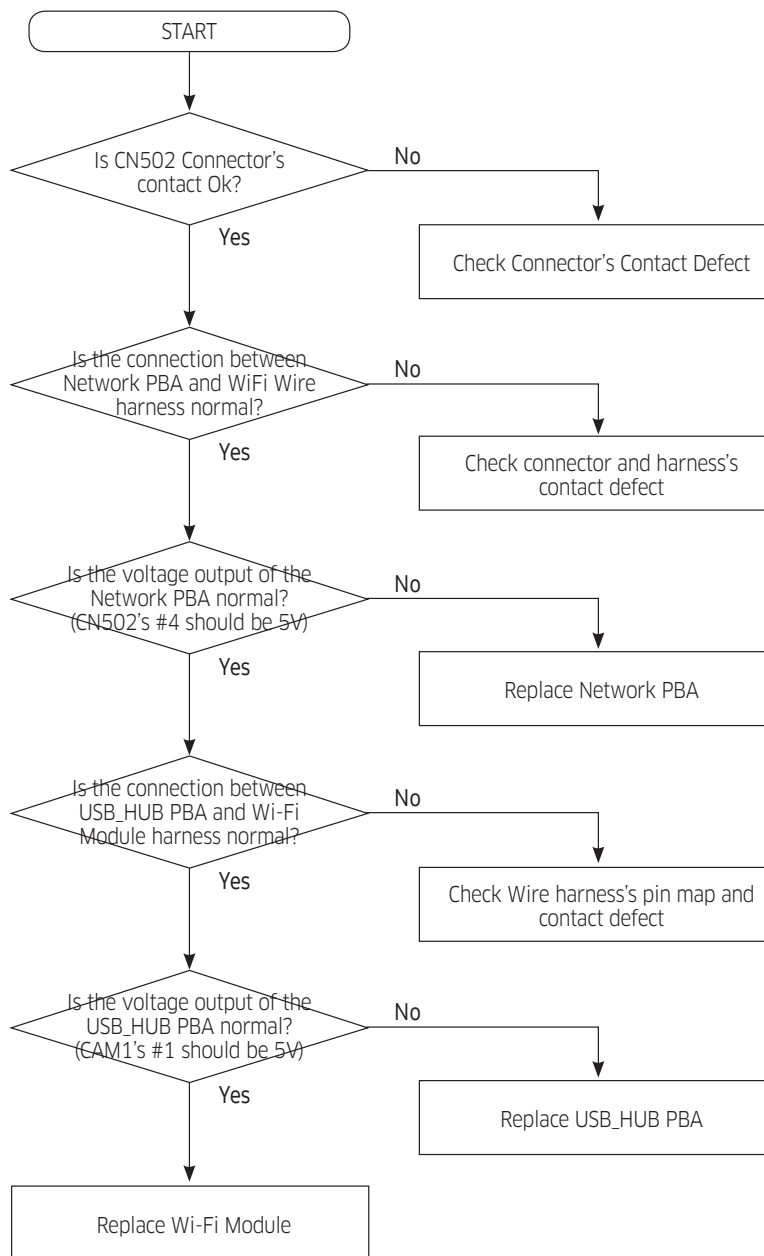

5. PCB DIAGRAM

5-1) PBA Layout with part position

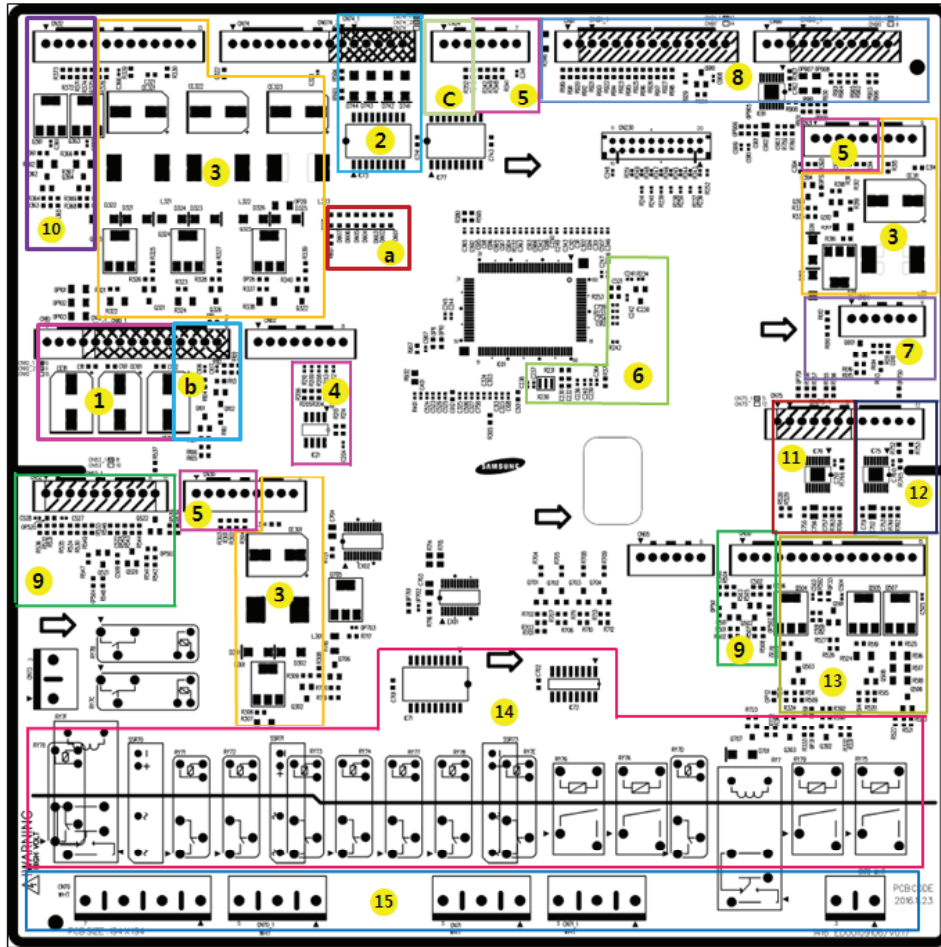

1. DC12V, 5V, GND supplied from SMPS PCB (Not Used)
2. Circuit for controlling Step-Valve (3-Way Valve) * Option
3. FAN MOTOR control part : To supply the power from 7V ~ 12V according to the motor types. (F,R,C,ICE)
4. EEPROM : Save and record every kinds of data.
5. Transmit inputted signals from every sensor into MICOM after eliminate the noise.
6. Micom : control the refrigerator Ceramic resonator : generate the basic frequency of Micom operation. Reset IC : make Micom reset if input voltage of Micom is detected less than the specified voltage
7. PLC input/output- PLC (Power Line communication) * Option (PLC module is not inserted unless specified occasion)
8. Operate ICE-MAKER, supply power to MOTOR, and sense the variation of switch.
9. Main Micom ↔ Panel Micom serial communication circuit - Dispenser option input part (Water & Cover Ice route switch)
10. Auto Fill control part
11. Control Mid drawer Room damper & Damper heater
12. Water Tank Heater Controls (also controls other options)
13. LED LAMP Control Circuit (F,R room Lamp)
14. Relay parts that controls AC load and receives Micom operating signal through Sink IC.
15. Connector with AC loads. Diode option setting area. Inverter COMP controlling signal c. Flow Sensor controlling signal

PCB DIAGRAM

5-2) Connector Layout & Descriptions of Inverter Controller Board

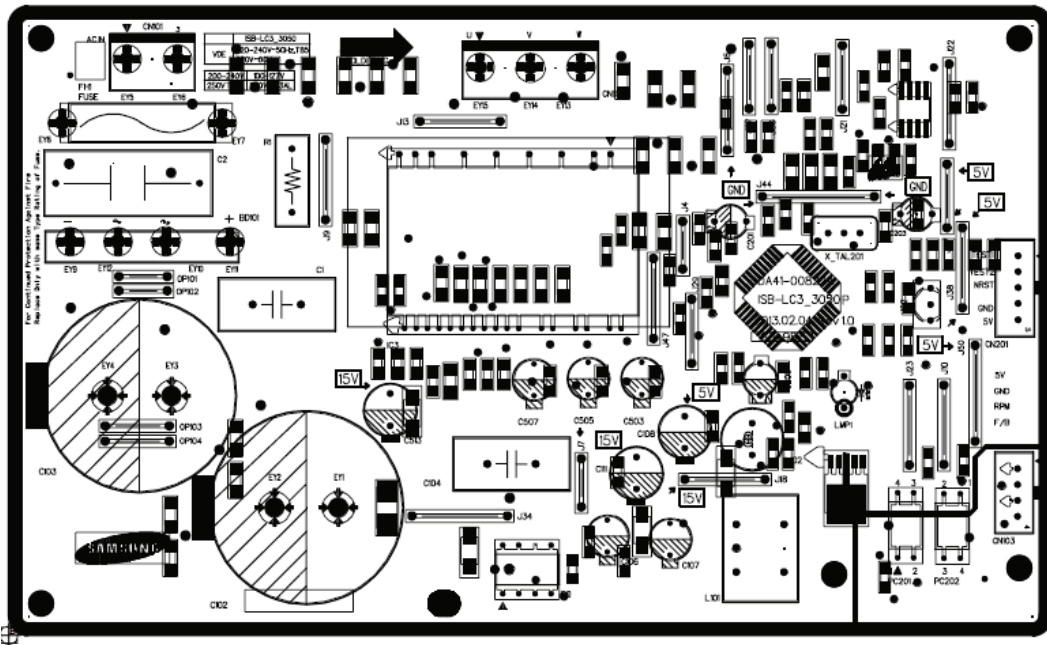

- PCB Power Supply : From the AC Input Voltage(115V), it supplies DC 15V and 5V to the Inverter circuit for the Compressor control.
- COMP Driving / Feedback Circuit It receives the COMP operation signals from the Main PBA and feedbacks the inverter errors to the Main PBA.
- Micom (MN103SFC2D)
- BOOTSTRAP Charger : It is an independent power circuit for the driving of the IMP High-Phase IGBT.
- Current Pickup Circuit : It pickups the currents taken by the Shunt resistance and does the PWM DUTY control.
- IPM (FNB40560)
- Micom (MN103SFC2D)

PCB DIAGRAM

5-3) Connector Layout with part position (Main Board)

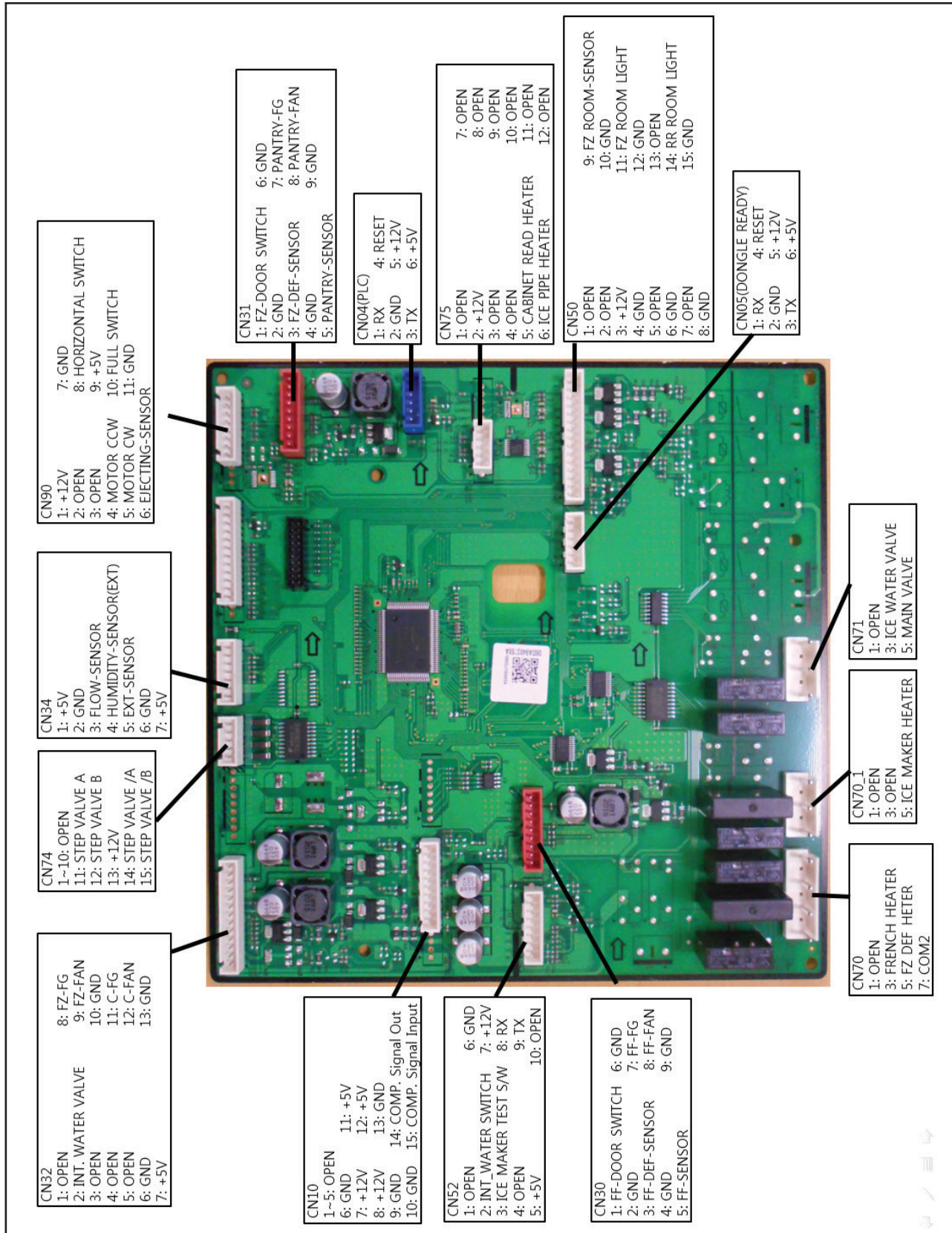

PCB DIAGRAM

5-4) Connector Layout with part position (Inverter PBA, SMPS PBA)

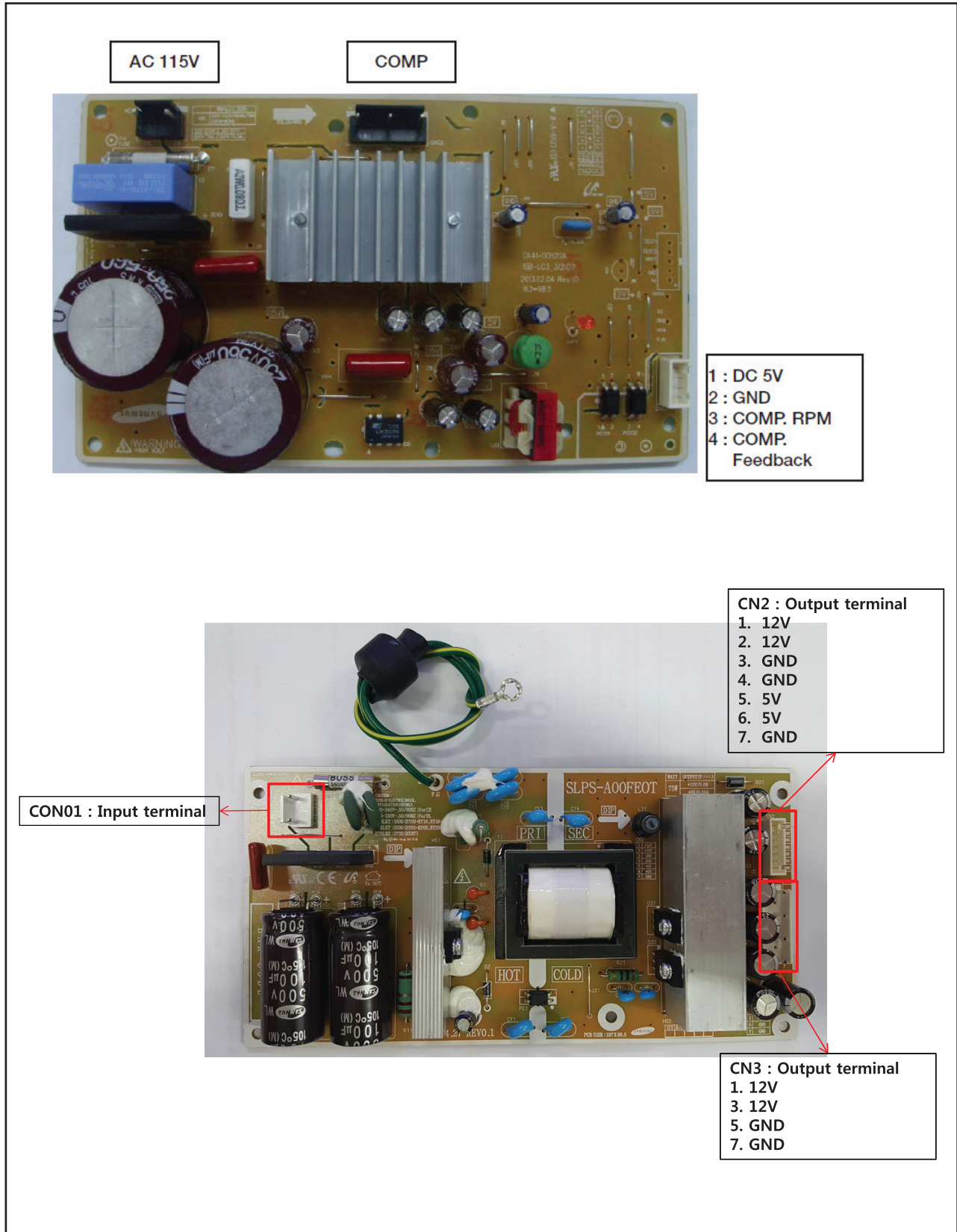

PCB DIAGRAM

5-5) Network PBA(DA92-00960A)'s Pin assignment

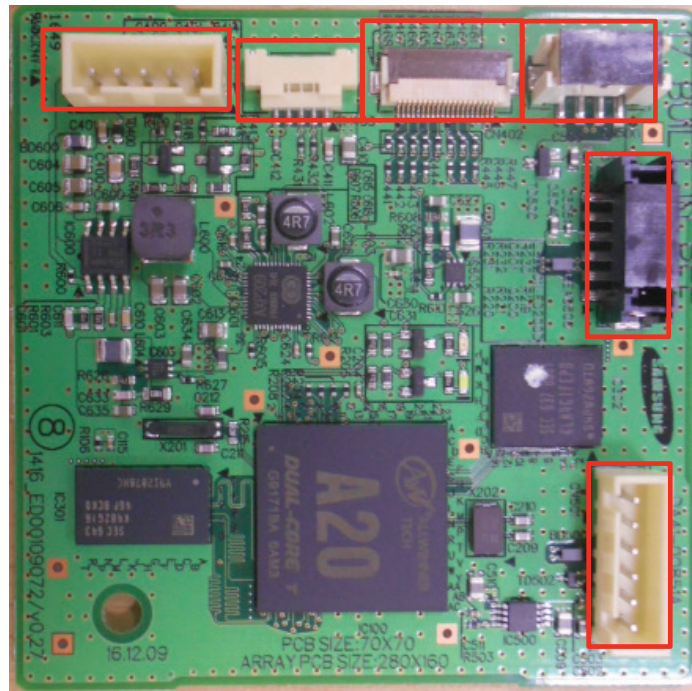

CN401: MAIN PBA <-> A20 Connection
 #1: UART TX / #2: UART RX / #3: RESET / #4:
 GND / #5: 12V

CN403: Debug Con(Not-populated for MP)
 #1: 12V / #2: UART TX / #3: UART RX / #4:
 GND / #5: 3.3V

CN402: SD Con(SW Update)
 #1: GND / #2: 3.3V / #3: GND / #4: NC / #5: GND / #6: SD_WP / #7: GND / #8:
 SD_DAT1 / #9: GND / #10: SD_DAT0 / #11: GND / #12: SD_CLK / #13: GND /
 #14: SD_CMD / #15: GND
 #16: SD_DAT3 / #17: GND / #18: SD_DAT2 / #19: SD_CD / #20: GND

CN500: MP Line Function Test
 #1: +5V / #2: D+ / #3: D- / #4: GND

CN502: Wi-Fi/LTE Module
 #1: GND / #2: D+ / #3: D- /
 #4: 5V / #5: NC / #6: GND

CN501: Camera Module
 #1: 5V / #2: 5V / #3: D- / #4: D+ /
 #5: GND / #6: GND

PCB DIAGRAM

5-6) Wi-Fi Module(4709-002331)'s Pin Assignment



CN1: Network PBA <-> Wi-Fi Module
#1: GND / #2: D+ / #3: D- / #4: 5V / #5: NC / #6: NC

5-7) USB_HUB PBA(DA92-00961A)'s Pin Assignment

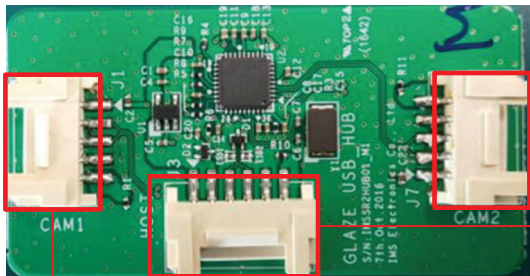

J2(CAM2): Wi-Fi Module
#1: 5V / #2: D- / #3: D+ / #4: GND / #5: GND

J3(HOST): USB_HUB PBA <-> Network PBA
#1: 5V / #2: 5V / #3: D- / #4: D+ / #5: GND / #6: GND

J1(CAM1): LTE Gender
#1: 5V / #2: D- / #3: D+ / #4: GND / #5: GND

6. BLOCK DIAGRAM

6-1) Whole block diagram

MAIN BLOCK

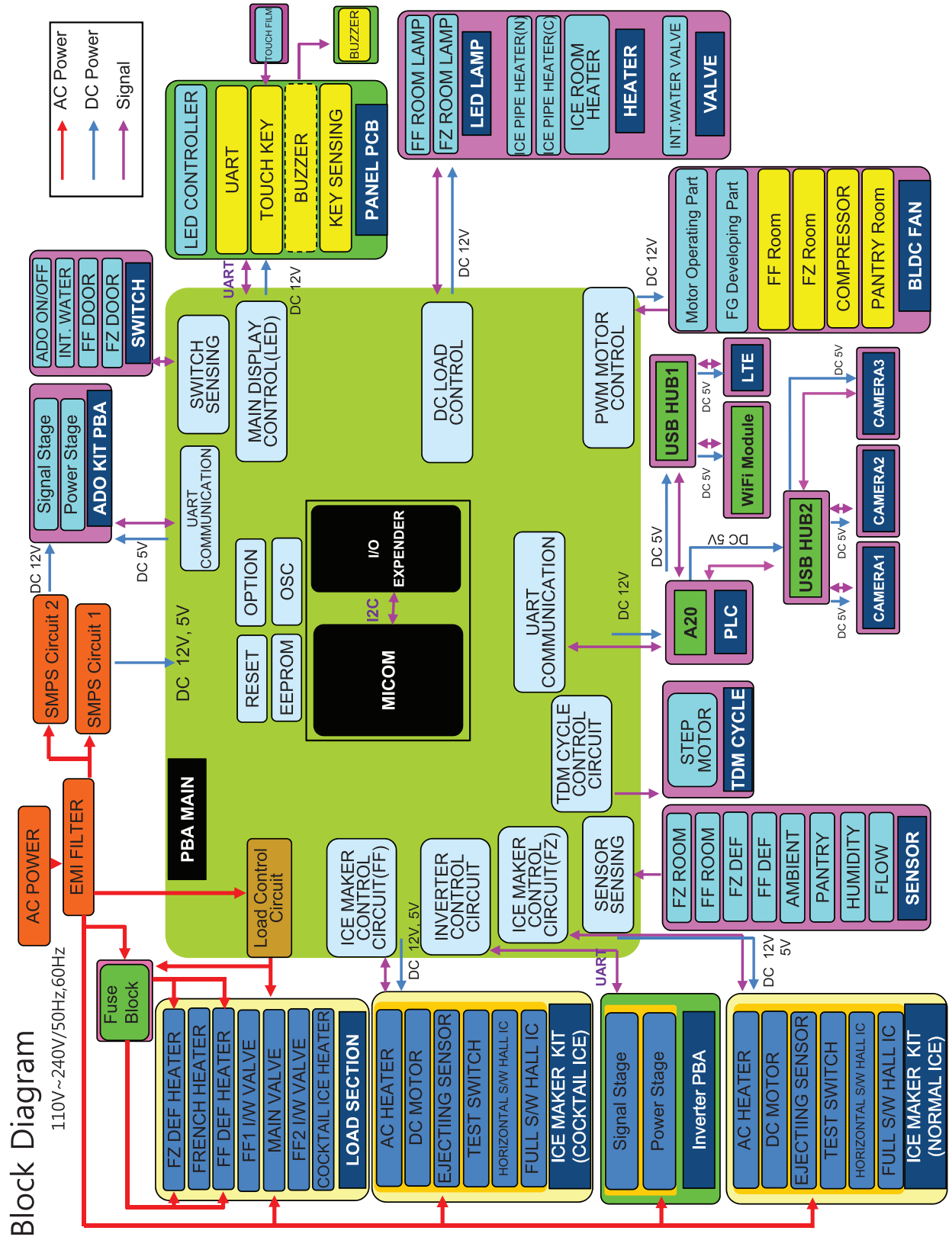

7. REFERENCE INFORMATION

7-1) Trouble Shooting

PROBLEM	SOLUTION
<p>The Refrigerator does not work at all or it does not chill sufficiently.</p>	<ul style="list-style-type: none"> • Check that the power plug is properly connected.
	<ul style="list-style-type: none"> • Check the set temperature on the digital display is warmer than freezer or fridge inner temperature.
	<ul style="list-style-type: none"> • Try setting it to a lower temperature.
	<ul style="list-style-type: none"> • Is the Refrigerator in direct sunlight or located near a heat source?
<p>The food in the Refrigerator is frozen.</p>	<ul style="list-style-type: none"> • Check the set temperature on the digital display is too low.
	<ul style="list-style-type: none"> • Try setting it to a warmer temperature.
	<ul style="list-style-type: none"> • Is the temperature in the room too low? Try setting it to a warmer temperature.
	<ul style="list-style-type: none"> • Did you store the food which is juicy in the coldest part of the Refrigerator? Try moving those items on the other shelves in fridge instead of keeping them in the Cool Select Pantry™.
<p>You hear unusual noise or sounds.</p>	<ul style="list-style-type: none"> • Check that the Refrigerator is level and stable.
	<ul style="list-style-type: none"> • Was anything dropped behind or under the Refrigerator?
	<ul style="list-style-type: none"> • A “ticking” sound is heard from inside the Refrigerator. It is normal and occurs because various accessories are contracting or expanding according to the temperature of the Refrigerator interior.
<p>The front corners and vertical hinged section of the appliance are hot and condensation is occurring.</p>	<ul style="list-style-type: none"> • Some heat is normal as anti-condensators are installed in the vertical hinged section of the Refrigerator to prevent condensation.
	<ul style="list-style-type: none"> • Is the Refrigerator door ajar? Condensation can occur when you leave the door open for a long time.
	<ul style="list-style-type: none"> • If a sound that hit something is heard from inside the refrigerator, it is normal and occurs because ice dropping make a sound by periods.

REFERENCE INFORMATION

PROBLEM	SOLUTION
Ice Maker is not producing ice.	<ul style="list-style-type: none"> • Did you wait for 12 hours after installation of the water supply line before making ice?
	<ul style="list-style-type: none"> • Is the water line connected and the shut-off valve opened?
	<ul style="list-style-type: none"> • Is the Freezer temperature too warm? Try setting the Freezer temperature lower.
You can hear water bubbling in the Refrigerator.	<ul style="list-style-type: none"> • This is normal. The bubbling comes from the Refrigerator coolant liquid circulating through the Refrigerator.
There is a bad smell in the Refrigerator.	<ul style="list-style-type: none"> • Check for spoiled food.
	<ul style="list-style-type: none"> • Foods with strong odors(for example, fish) should be tightly covered.
	<ul style="list-style-type: none"> • Clean out your Freezer periodically and throw away any spoiled or suspicious food.
Frost forms on the walls of the Freezer	<ul style="list-style-type: none"> • Is the air vent blocked? Remove any obstructions so air can circulate freely.
	<ul style="list-style-type: none"> • Allow sufficient space between the foods stored for efficient air circulation.
	<ul style="list-style-type: none"> • Is the Freezer drawer closed properly?
Water dispenser is not functioning.	<ul style="list-style-type: none"> • Is the water line connected and the shut-off valve opened?
	<ul style="list-style-type: none"> • Has the water supply line tubing been crushed or kinked? Make sure the tubing is free and clear of any obstruction.
	<ul style="list-style-type: none"> • Is the water tank frozen because the Refrigerator temperature is too low? Try selecting a warmer setting on the Digital display.

REFERENCE INFORMATION

7-2) Q&A

Descriptions of symptoms	Check Points	Corrective Measures
<p>► Noise (resonance) problems keep on even though the noise generating BLDC motors for both of the compartments are replaced several times. What does generate the resonance and how can it be settled down?</p>	<p>When the BLDC fan motor rotates in low RPM, The friction with air is quite high and it generates “grinding” noises.</p>	<p>If you replace the ambient thermistor with a 2.7K resistance (detecting 109.4 °F), the BLDC fan motor rotates in high RPM, which reduces friction with air resulting in reduction of the “grinding” resonance.</p>
<p>► What causes the “knocking” noises? How to solve it?</p>	<p>It makes “knocking” or “branch breaking” noises when the liner and the shelves hit each other due to the fluctuation of the inside air pressure upon door open/close. Also, these noises occur when the liners and the shelves hit each other as the liners expand and contract due to the temperature change in both of the compartments.</p>	<p>Check the clearance between the selves and the liners.</p> <p>① Freezer Shelves: Remove the trim shelves already attached and replace them with those supplied for service.</p> <p>② Fridge Shelves: Because noise-preventing trim selves are not attached, it needs attaching.</p>
<p>► What is the solution if the same problem occurs even though the counter action in the service bulletin has been implemented already for the “knocking” noises?</p>	<p>Check if the selves wobble. If they do, have shelves sit firmly on their places.</p>	
<p>► What causes the liquid passing noises from the back of the refrigerator?</p>	<p>Refrigerant goes into the evaporator via the capillary tube in which the refrigerant expands as it circulates the cooling cycle. At this time, the refrigerant is in its liquid state and it starts evaporating as it reaches at the inlet of the evaporator with a bigger diameter, which causes the refrigerant noises. And, it gets worse when the refrigerant does not flow freely.</p>	

REFERENCE INFORMATION

Descriptions of symptoms	Check Points	Corrective Measures
<p>► What is the solution for the compressor noises?</p>	For new refrigerators	
	Check if the refrigerator is leveled.	Check if the refrigerator wobbles by shaking with hands.
	Check if there is enough clearance at the back of the refrigerator for the ventilation of the machine compartment.	If there is not enough clearance or it is blocked by things such as newspaper, there could be resonance noises.
	Required clearance around the product.	More than 2 inches from the back, 12 inches from the top and 4 inches from its sides.
<p>► What is the solution for the compressor noises?</p>	For old refrigerators	
	Dust could get built-up in the machine compartment. Then, its ventilation would get restricted which makes the refrigerator overheated resulting in the increase of the noise level.	Explain it to customers and let them clean dust or any other foreign substances in the machine compartment.
	As the vibration proof rubbers get hardened, noises generate during the comp operation. (The noise level is quite high.) → Replace the vibration proof rubbers.	The compressor is dislocated due to impact during its transportation such as moving-in. → Check if it's dislocated when it is more noisy after moving-in.
<p>► During the comp start-up, iron friction noises occur. What causes them?</p>	The reciprocation piston could get worn out or inner components could get dislocated.	
<p>► What can be checked when the unit sends out noises?</p>	<ol style="list-style-type: none"> 1. Check its symptoms and patterns. 2. Check if the unit is installed on a firm and leveled floor. 3. Check if the unit is installed close to the customer's living area. 4. Check if the panel on the machine compartment hits on the rear wall and the unit has enough clearance with the rear wall. 5. Check if the refrigerant pipes are shaped as normal. 	

REFERENCE INFORMATION

Descriptions of symptoms	Check Points	Corrective Measures
<p>▶ Why is the fridge compartment not cool? (Not a defect)</p>	<p>Advise customers to adjust its temperature level to one or two step higher. For example, when the ambient temperature is low such as in winter (especially, when you use it in the morning with the door not being opened or closed during the night), the compartment temperature could get increased by 33.8~35.6 °F. So, advise customers to shift its temperature level and explain to them that it does not affect its power consumption that much when its temperature setting is adjusted to one or two step lower.</p>	
<p>▶ Why is the food melt even though the display of the freezer compartment shows -4 °F?</p>	<p>Check the compartment temperature with a thermometer.</p>	<p>If it is considered to be low cooling, When the BLDC motor fan does not rotate because its restriction is not picked up. When the evaporator is frozen-up (defrost it) Temp detection error according to the characteristic change of the thermistor (set the compartment temperature or replace the thermoistor)</p>
<p>▶ What is the reason that vegetables get frozen even though the fridge compartment is set to MIN?</p>	<p>Replace the fridge thermistor because it could be faulty. 1st: Check if the thermistor works after referring to the self-diagnosis checklist on the MAIN-PCB cover. If the over-cooling keeps on even though there is no problem with the above, replace it.</p>	
<p>▶ What can be done when frozen food gets melt in the freezer compartment or it does not cool down?</p>	<p>Defrost it by using hot water and check the defrost system for any fault. And then, eliminate the root causes so as to prevent it from reoccurring.</p>	
<p>▶ Why doesn't the compressor operate upon power supply?</p>	<p>Upon the initial power on, the compressor starts operating after a five minute delay to protect the compressor. So, please wait until it starts operating.</p>	
<p>▶ Why does it send out "Ding Dong" or alarm sounds with the doors closed?</p>	<p>Check if the food sticks out preventing the doors from closing properly. If it send out the above sounds with the door closed well, the door switch may not have been pressed down completely. So, make sure for the door switches to be pressed completely. Still, if it does not stop going off, check the wiring connections because the door switch signals may not be inputted into the PCB. And, when the door switch is faulty or it is not pressed down completely, the fan does not rotate and it causes low-cooling advancing to a defrost problem.</p> <p>Note : When it comes to automatic models, the fan motor does not operate right on with the door closed after being opened. The fan motor for dual-evaporator refrigerators starts after a 50 °F~second delay and when the ambient temperature is higher than 91.4°F, it starts after a minute.</p>	

REFERENCE INFORMATION

Descriptions of symptoms	Check Points	Corrective Measures
<p>► What can be done when it sends out much smell in the fridge and the freezer compartments after 2 months?</p>	<p>When the stored food sends out much smell.</p> <ul style="list-style-type: none"> ☞ Check if there is any food sending out sustaining smells. Dried squid, dried laver : Hold on them Pounded garlic : Put it in an airtight container Medical herbs : Make sure they are packed airtight. Replace the old packing or wrap with a new one. Others : Check if the container is sealed or the food is packed airtight. <ul style="list-style-type: none"> ☞ Check if the compartment temperature is normal and the food is contaminated. ☞ Check if there are any overflow of side dishes on the shelves or the bottom of the compartments. ☞ Put the food sending out much smell in an airtight bag or container. ☞ Open the door and ventilate it. Also, clean liners, shelves, containers and door bins. 	
<p>► What is the cause and its counter action for chemical smells with new products?</p>	<p>During its delivery to customers, chemical smells from various components could build up inside of the compartments. So, please let the doors open for some time to use the unit.</p>	<p>Precautions : Smells tend to get soaked into the liners or other components. If food generating much smell is stored inside, it would stick onto the liners and other components and it is so difficult to remove the smell. Especially, customers should take care in storing smelly food properly with its sealing being tight during the early period of the product's use.</p>
<p>► What can be done when the smell keeps on even though the deodorizers are cleaned?</p>	<ol style="list-style-type: none"> 1) Turn off the refrigerator (unplug the unit) and remain the door opened. 2) Take out the food stored in the refrigerator. And then, take out all the shelves, door bins and containers, and put them in warm water. After cleaning them by using dish detergents and drying them, put them back to their locations. 3) Remove the deodorizer and soak it in warm water more than 4 hours. After drying it in sunlight, put it back to its location. 4) Throw away the smell-soaked plastic bags and put the food in new ones. 	
<p>► What causes the funny smell in water?</p>	<p>When it tastes and smells funny</p> <ul style="list-style-type: none"> ☞ It tastes funny even though it does not smell funny. 	<p>It could happen when remnants of the water filter or organics have been built up in the water tank. So, replace the water filter and the water tank together. If there is no replacement part and the water tank need cleaning, use dish detergents and make sure to clean the inside without any detergents remaining inside.</p>

dacor[®]

Printed in Korea