

**SAMSUNG**

# REFRIGERATOR

**BUILT IN REFRIGERATOR**

**BASIC MODEL : BRF425200AP/AA**

**MODEL CODE : DRF425300AP/DA**

# ***SERVICE*** Manual

## REFRIGERATOR



## CONTENTS

- 1. PRECAUTIONS (SAFETY WARNINGS) .....5
- 2. PRODUCT SPECIFICATIONS .....9
- 3. FULL DISASSEMBLY AND ASSEMBLY..... 15
- 4. TROUBLESHOOTING ..... 40
- 5. PCB DIAGRAM ..... 89
- 6. WIRING DIAGRAM..... 94
- 7. BLOCK DIAGRAM ..... 96
- 8. REFERENCE INFORMATION..... 97



## **WARNING**

### **IMPORTANT SAFETY NOTICE**

The service guide is for service technicians with sufficient background in electrical, electronic and mechanical engineering.

Any attempt to repair the appliance yourself may result in personal injury and property damage.

The manufacturer or dealer will not be held responsible for the interpretation of this information.

All rights reserved. This service guide may not be reproduced in whole or as a part in any form whatsoever without the written permission of the SAMSUNG ELECTRONICS Company.

# Contents

<b>1. Precautions (safety warnings).....</b>	<b>5</b>
<b>2. Product specifications .....</b>	<b>9</b>
2-1) Product Specifications.....	9
2-2) Dimensions of Refrigerator (Inches).....	11
2-3) Refrigeration Cycle.....	12
2-3-1. Cold Air Circulation .....	13
2-4) Interior Overview.....	14
<b>3. Full disassembly and assembly.....</b>	<b>15</b>
3-1) PRECAUTION .....	15
3-2) Internal Dispenser.....	17
3-3) Bin & Shelf & Drawer .....	19
3-4) Ice Maker .....	20
3-5) DAMPER.....	21
3-6) Case Water Filter .....	26
3-7) HINGE COVER.....	27
3-8) Door.....	28
3-9) Unit.....	30
3-10) Case water filter & Water valve.....	32
3-11) PCB Box.....	33
3-12) Procedure of Service lokring .....	35
3-13) Evap.....	36
3-14) COMPRESSOR .....	37
3-15) FRENCH .....	38
3-16) COVER LAMP .....	39
<b>4. Troubleshooting .....</b>	<b>40</b>
4-1) Function for failure diagnosis.....	40
4-1-1. Test Function (Forced Operation/ Forced Defrost Function).....	40
4-1-2. Self-diagnosis function.....	44
4-1-3. Load Condition Display functions.....	52
4-1-4. Operation Condition Restore Function For Blackout .....	55
4-1-5. Cooling Off Setting Function.....	55
4-1-6. Display function of Communication error .....	56
4-1-7. Entering AP Mode and Samsung Connect Product Registration.....	56
4-1-8. MAC Address Display Mode.....	57
4-1-9. Option Setting Function .....	58
4-2) Diagnostic method according to the trouble symptom (Flow Chart).....	68
4-3) Case Output Terminal .....	70
4-4) How to Enter the Test Mode .....	76

# Contents

<b>5. PCB Diagram .....</b>	<b>89</b>
5-1) PBA Layout with part position .....	89
5-2) Connector Layout & Descriptions of Inverter Controller Board.....	90
5-3) Connector Layout with part position (Main Board) .....	91
5-4) Connector Layout with part position (Inverter PBA, SMPS PBA) .....	92
5-5) Wi-Fi Module(4709-002829)'s Pin Assignment .....	93
<b>6. Wiring Diagram.....</b>	<b>94</b>
<b>7. Block Diagram .....</b>	<b>96</b>
<b>8. Reference information.....</b>	<b>97</b>
8-1) Trouble Shooting .....	97
8-2) Q&A.....	99

# 1. PRECAUTIONS (SAFETY WARNINGS)

- Unplug the appliance before replacing or repairing electrical parts.
  - Be careful to avoid electric shock.
- Always use only the correct replacement parts. Check the model name, rating voltage, rating current, running temperature symbols.
- When troubleshooting, verify that wiring harnesses are connected securely. Make sure the connectors are not separated when power is supplied.
- Check for visible traces of water on electrical parts. Replace or secure any part that may have come in contact with water.
- Check the status of parts after replacement or troubleshooting.
  - All parts must be reinstalled properly.
- Check the location where the refrigerator will be used. If the refrigerator will be used in a damp or wet space, or if installation will be unstable, the unit should be relocated.
- The refrigerator must be grounded properly. An earth ground should be used if there is a risk of high humidity or wetness.
- The refrigerator should be plugged into a dedicated outlet. Make sure the power cord is not damaged, crushed, squeezed or burned. If the plug is damaged it should be replaced.
  - If the socket is damaged, it should not be used.
- Consumers must not try to repair the refrigerator.
- Nothing should be stored in the refrigerator except food. Drugs requiring precise temperatures should not be stored in the refrigerator.
  - Flammable substances (alcohol, benzene, ether, LP gas, etc.) carry risk of explosion and should not be stored in the refrigerator.







# PRECAUTIONS (SAFETY WARNINGS)





**Read all instructions before repairing the product and keep to the instructions in order to prevent danger or property damage.**

## CAUTION/WARNING SYMBOLS DISPLAYED

 <b>Warning</b>	Indicates that a danger of death or serious injury exists.
 <b>Caution</b>	Indicates that a risk of personal injury or material damage exists.









## SYMBOLS

	means "Prohibited".
	means "Do not disassemble".
	means "No contact".
	means "The things to be followed".
	means "Unplug the unit before performing service"
	means "Earth or Ground".

 <p><b>Unplug to exchange the interior lamp.</b></p> <ul style="list-style-type: none"> <li>• It may cause electric shock.</li> </ul>	 <p><b>Unplug Use the rated components on the replacement.</b></p> <ul style="list-style-type: none"> <li>• Check the correct model, rated voltage, rated current, operating temperature and so on. On repair, make sure that the all wiring harnesses are reconnected.</li> <li>• Wiring harnesses should be connected tightly and kept dry.</li> <li>• Bundle tightly wires in order not to be detached by the external force and then not to be wetted.</li> </ul>	
 <p><b>On repair, Make sure that all parts and wires are free of dust and debris.</b></p> <ul style="list-style-type: none"> <li>• Cleaning parts could help prevent fire or shorting.</li> </ul>	 <p><b>Check the status of parts after replacement or troubleshooting.</b></p> <ul style="list-style-type: none"> <li>• All parts must be reinstalled properly.</li> </ul>	 <p><b>Check for visible traces of water on electrical parts.</b></p> <ul style="list-style-type: none"> <li>• Replace or secure any part that may have come in contact with water.</li> </ul>

# PRECAUTIONS (SAFETY WARNINGS)

※ Please let users know following warnings & cautions in detail.

 <p>Customers should not store glass bottles of liquid in the freezer section. Frozen bottles could explode and cause injury.</p>	 <p>Customers should not store narrow or long bottles or food in a small door shelf.</p> <ul style="list-style-type: none"><li>• <i>These items could fall when the door is opened, causing injury to the customer.</i></li></ul>	 <p>Drugs requiring precise temperatures should not be stored in the refrigerator.</p>
 <p>The refrigerator should be plugged into a dedicated outlet.</p> <ul style="list-style-type: none"><li>• <i>Multiple plugs in the outlet could cause excessive heat or fire.</i></li></ul>	 <p>Consumers must not try to repair the refrigerator.</p> <ul style="list-style-type: none"><li>• <i>Electrical and mechanical parts could injure the consumer.</i></li></ul>	 <p>Make sure the power cord is not damaged or crushed.</p> <ul style="list-style-type: none"><li>• <i>A damaged cord could cause excessive heat or fire.</i></li></ul>
 <p>Articles on the product.</p> <ul style="list-style-type: none"><li>• <i>Opening or closing the door may cause things to fall down, which may cause injury.</i></li></ul>	 <p>Check the location where the refrigerator will be used.</p> <ul style="list-style-type: none"><li>• <i>If the refrigerator will be used in a damp or wet space, or if installation will be unstable, the unit should be relocated.</i></li></ul>	 <p>The refrigerator must be grounded properly.</p> <ul style="list-style-type: none"><li>• <i>An earth ground should be used if there is a risk of high humidity or wetness.</i></li></ul>

## PRECAUTIONS (SAFETY WARNINGS)

### WARNING

Be careful, otherwise people who are helping may be injured or the appliance may be damaged. The appliance is very heavy.

1. Transport the appliance to a suitable installation location with suitable means of transportation (trolley, lifting truck or hand).
2. Secure the appliance during transportation to prevent it from tipping.
3. Move and install with a minimum of two persons.
4. Be very careful to avoid floor damage. Delicate flooring should be protected with plywood, hard cardboard, or similar material
5. Before transporting the appliance, check access to the location where it will be installed (door size, maneuvering space in stairwells, etc.).

\* **TIP OVER HAZARD:** This appliance is large, heavy and tips easily when not installed. Always transport in an erect position if possible. If this is not possible, transport laying on the back side. Keep doors taped shut during transport.



## 2. PRODUCT SPECIFICATIONS

### 2-1) Product Specifications

Model		Basic model		New model	
		BRF425200AP/AA		DRF425300AP/DA	
Type		T-Type			
Region		North America			
Brand		Samsung		Dacor	
Series		CHEF			
Basic	W x H x D (inch)		42x84x24		
	Energy		E-Star		
Exterior	Installation Option		Integrated		
	Door Panel		Panel Ready		
	Handle Design (OPT)		CHEF		
Fridge	Cabi	Display		Gray Glass, Blue LED	Gray Glass, White LED
		Lighting		3 sided LED	
	Precise Cooling		○		
	Door	Door Bin Material /EA		SAN (Gray) / 6EA	
Freezer	Cabi	Lighting		TOP LED	
		Ice Maker	Standard	○	
			Cocktail	X	
	Precise Cooling		○		
Smart	Wifi Module		A20 NETWORK PBA + WIDT30Q (USB)	TP2X	
	Smart Camera		○	X	
Cycle	Refrigerant	Freezer		R600a / 53g	
		Refrigerator		R600a / 43g	
	Cycle	Freezer		TDM (CV/F)	
		Refrigerator		Mono	
	Comp	Freezer		NF54K9151AM (F5)	
		Refrigerator		NN35J9602AP (M3)	
	Evap.	Freezer		F/CV:Fin-Tube	
				T0.8Xø8.0XL5.0 , 0.60m <sup>2</sup>	
				CV : No Accum	
		Refrigerator		F : Accum 105mm	
				No Sleeve	
				Fin-Tube	
	Cond.	Condenser		R: PFC B Type, 0.90m <sup>2</sup>	
				F: PFC B Type, 0.90m <sup>2</sup>	
		Hot Pipe	Freezer	T0.7Xø4.0XL5,702	
			Refrigerator	T0.7Xø4.0XL5,928	
	Suction Pipe	Freezer		T0.45*ø7.94*L2,923	
				SLHX 2,500	
		Refrigerator		T0.45*ø7.94*L2,506	
	Capillary	Freezer		SLHX 2,100	
F: ø0.75XL3,600					
Refrigerator		CV: ø0.75XL3,600			
		ø0.85XL3,700			

# PRODUCT SPECIFICATIONS

Model		Basic model		New model	
		BRF425200AP/AA		DRF425300AP/DA	
Type		T-Type			
Region		North America			
Brand		Samsung		Dacor	
Series		CHEF			
Cycle	Extra.	Valve		R: 2-Way, F: 3-way	
		Humidity sensor		○	
Electric	Motor & Fan	REF, FRE, CV		BLDC(AIO Q7), ø120 11Wing, DC12V	
				BLDC(C160), ø160, 3Wing, DC12V	
		Flex Zone		BLDC BOX Fan 92mm, DC12V	
	Heater	F-Evap.		Metal Sheath Heater	
		CV-Evap.		Metal Sheath Heater	
		French		AC Cord Heater, 120V 12W	
		Water Pipe (Cabi Rear)		DC Cord Heater, DC12V 2W	
		Ice maker (Standard)		AC 120V 145W , AL	
		Water Pipe (Standard)		DC12V, 2.3W	
		Ice maker (Cocktail)		-	
	PCB	MAIN		194mm*194mm, FR4	
		SMPS		85W * 1EA	
		Invertor		LC3 3050_V2	
		DISPLAY		LED TYPE, Touch Button	
	Heater Protect	FRE, CV		Bimetal-Thermo [Off60℃,On40℃]	
	Lamp	FRE / CV(TOP)		Lens Type, FR-4, DC12V, 3535PKG	
		REF	TOP	Lens Type, FR-4, DC12V, 3535PKG	
			Side	Lens Type, FR-4, DC12V, 5630PKG	
	Step Valve	4Way		DC 12V, 700mA,9.8W Step Motor	
	Switch	Power Switch		AC 250V 16A	
Sensor	Defrost		DK(ST1329GW)		
	Humidity		DK(SHT20P)		

# PRODUCT SPECIFICATIONS

## 2-2) Dimensions of Refrigerator (Inches)

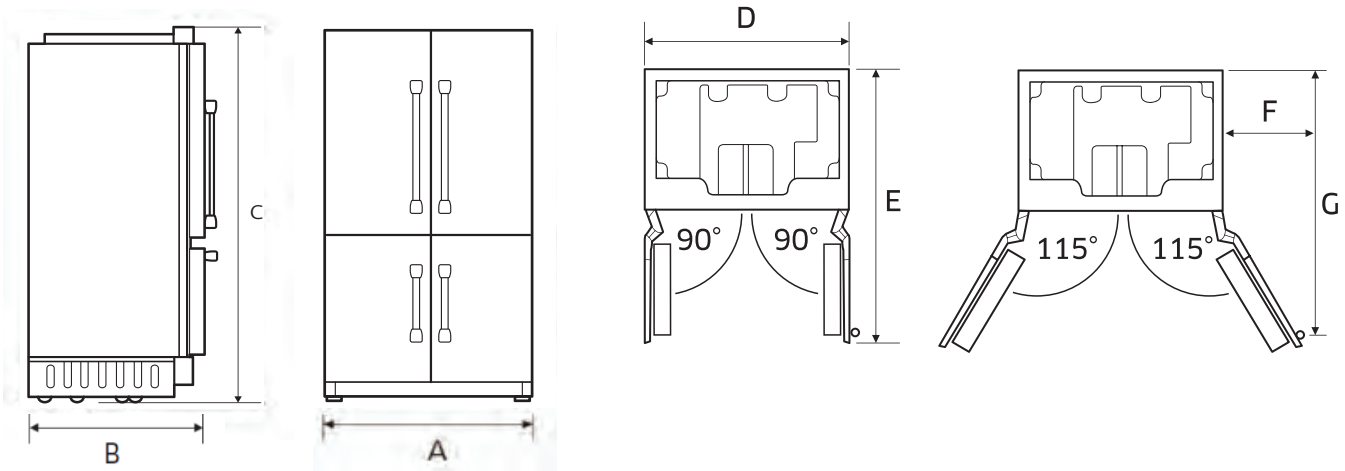

Callout	42"
A (Width)	41 3/4" (1060 mm)
B (Depth)	24 11/16" (627 mm)
C (Height)	83 3/8" (2118 mm)
D	41 1/4" (1048 mm)
E	48 1/2" (1232 mm)
F	22 7/16" (570 mm)
G	47 5/8" (1210 mm)

# PRODUCT SPECIFICATIONS

## 2-3) Refrigeration Cycle

1. Freezer : Compressor → Immerging Pipe → Condenser → Hot Pipe → Dryer → 3-Way Valve → Cool Select Room Capillary Tube → Cool Select Room Evaporator  
↓  
Suction Pipe → Compressor  
↑  
Freezer Capillary Tube → Ice-maker → Freezer Evaporator

2. Fridge : Compressor → Immerging Pipe → Condenser → Hot Pipe → Dryer → 2-Way Valve → Fridge Capillary Tube → Fridge Evaporator → Suction Pipe → Compressor

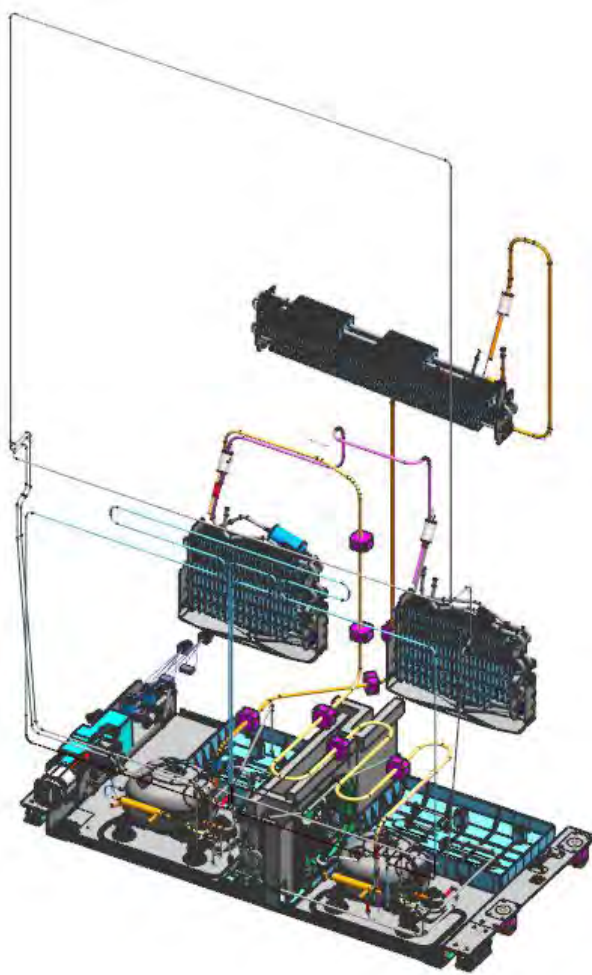

[FRONT-SIDE VIEW]

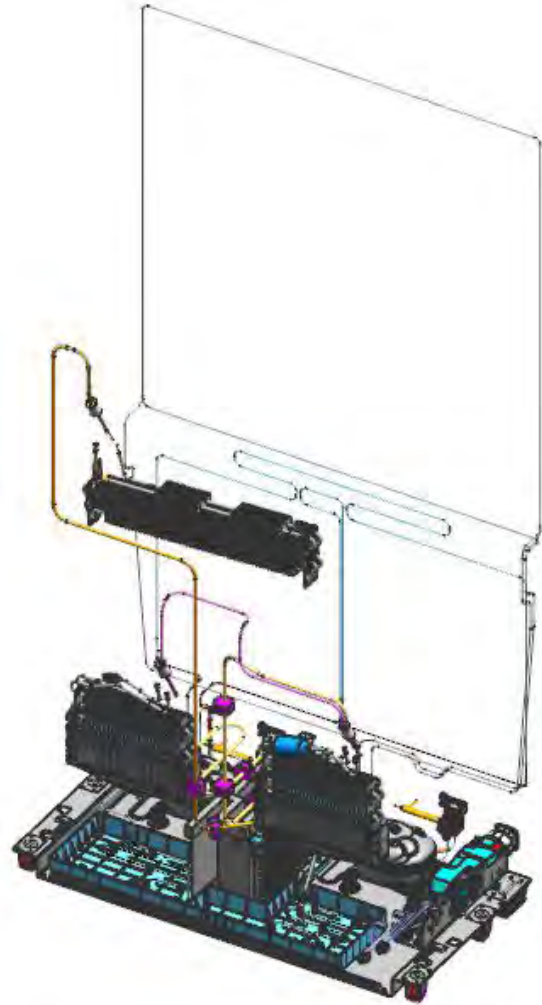

[ REAR-SIDE VIEW]

# PRODUCT SPECIFICATIONS

## 2-3-1. Cold Air Circulation

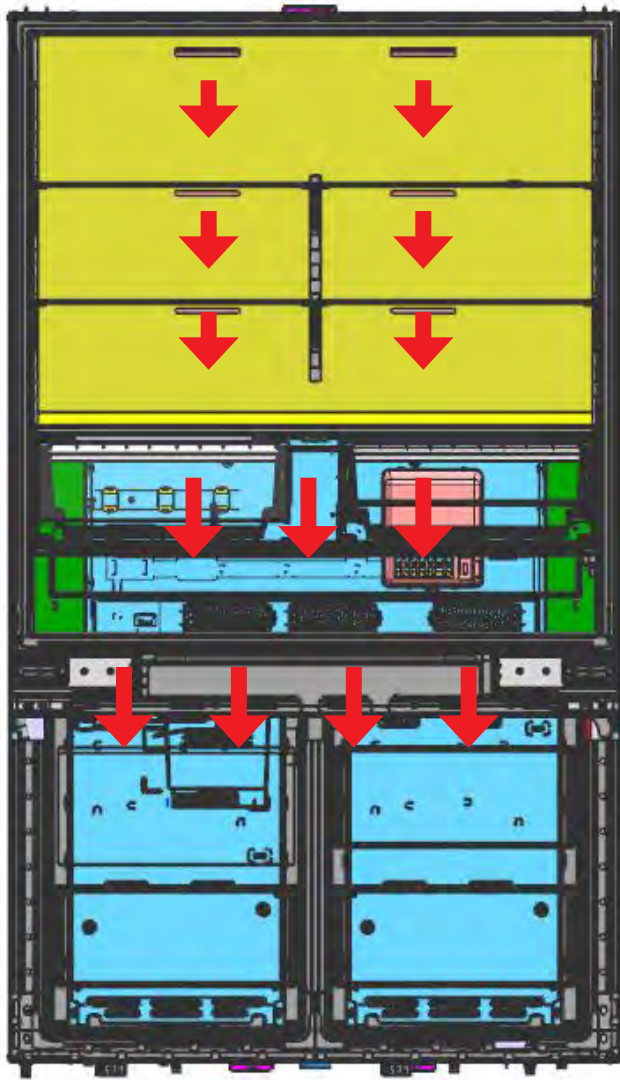

FRONT

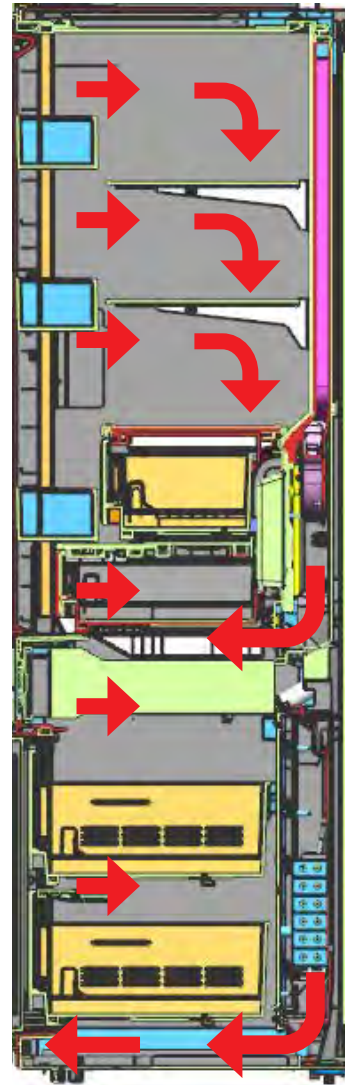

SIDE

# PRODUCT SPECIFICATIONS

## 2-4) Interior Overview

### Inside Parts, Storage, and Shelving

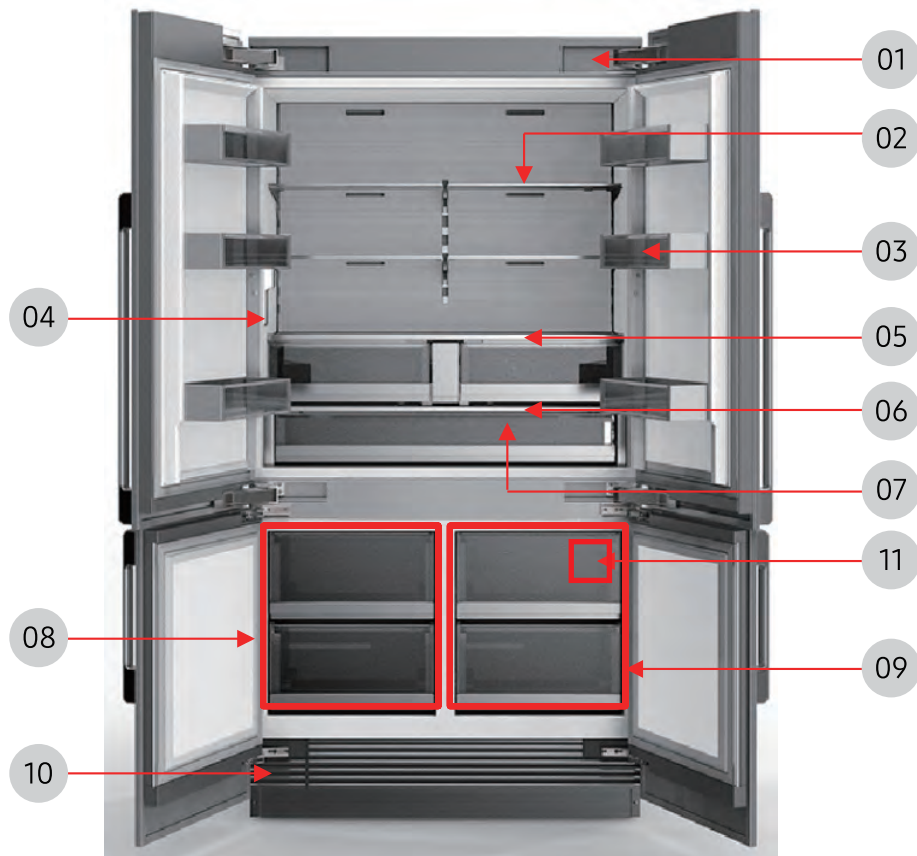

- 01 Power switch
- 03 Door bins
- 05 Metal/ceramic shelf
- 07 FreshZone
- 09 FreshZone+
- 11 Serial Number (on the FreshZone+ wall)

- 02 Glass shelves
- 04 Water dispenser
- 06 Control panel
- 08 Freezer
- 10 Water filter (cover)











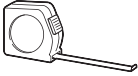
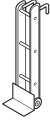

## 3. FULL DISASSEMBLY AND ASSEMBLY

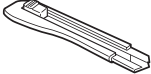
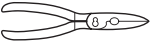
### 3-1) PRECAUTION

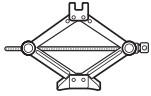
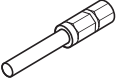
- Unplug the refrigerator before cleaning and making repairs.
- Do not disassemble or repair the refrigerator by yourself.
  - It may cause risk of causing a fire, malfunction and/or personal injury.
- Remove any foreign matter or dust from the power plug pins.
  - Otherwise there is a risk of fire.
- Do not use a cord that shows cracks or abrasion damage along its length or at either end.
- Do not plug several appliances into the same multiple power board. The refrigerator should always be plugged into its own individual electrical which has a voltage rating that matched the rating plate.
  - This provides the best performance and also prevents overloading house wiring circuits, which could cause a fire hazard from overheated wires.
- Do not install the refrigerator in a damp place or place where it may come in contact with water.
  - Deteriorated insulation of electrical parts may cause an electric shock or fire.
- The refrigerator must be grounded.
  - You must ground the refrigerator to prevent any power leakages or electric shocks caused by current leakage from the refrigerator.
- Do not put bottles or glass containers in the freezer.
  - When the contents freeze, the glass may break and cause personal injury.
- Do not store volatile or flammable substances in the refrigerator.
  - The storage of benzene, thinner, alcohol, ether, LP gas and other such products may cause explosions.

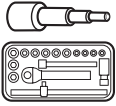
# FULL DISASSEMBLY AND ASSEMBLY

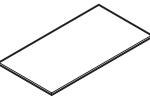



## - Tools required

NO	Tool		NO	Tool	
1		Electric Screwdriver	9		Stepladder
2		Measuring Tape	10		Appliance Dolly
3		Flat/Slot Head Screwdriver	11		Cutter
4		Cutter (Scissors)	12		Level
5		Adjustable Wrench	13		Jack
6		Phillips Head Screwdriver	14		Combination Wrench 3/8" (10 mm), 1/2" (13 mm)
7		Ratchet 3/8" (10 mm), 1/2" (13 mm)	15		SVC LOKRING TOOL KIT
8		Protective Floor Mat	16		UV LAMP





# FULL DISASSEMBLY AND ASSEMBLY

## 3-2) Internal Dispenser

Part Name	How To Do	Descriptive Picture
<b>Internal Dispenser</b>	1. Remove the CAP DISPENSER with a flat-head screwdriver.	
	2. Unscrew one screw.	 
	3. Put a flat-head screwdriver under the ASSY, and lift it up as shown in the picture.	

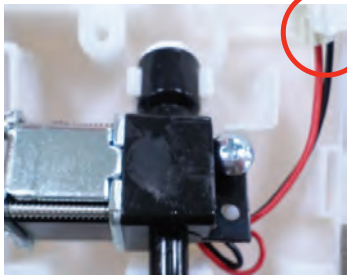
# FULL DISASSEMBLY AND ASSEMBLY

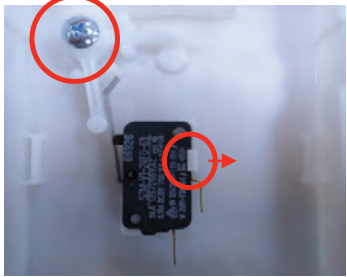
Part Name	How To Do	Descriptive Picture
<b>Internal Dispenser</b>	4. Pull the VALVE wire down, and disconnect the cable.	
	5. Unscrew 1 SCREW using a cross-head screwdriver.	
	6. Detach LINK using a cross-head screwdriver  7. Push the holder towards the direction of the arrow and remove the SWITCH.	



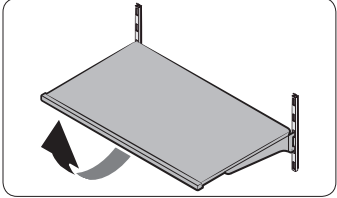
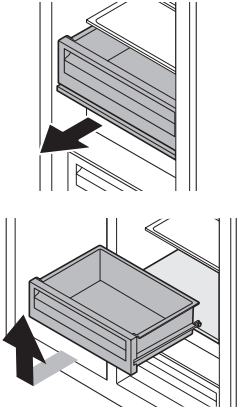

# FULL DISASSEMBLY AND ASSEMBLY

## 3-3) Bin & Shelf & Drawer

Part Name	How To Do	Descriptive Picture
<b>Bin</b>	1. After lifting up the Door Bin, Push it towards the chest and disassemble the Door Bin. After lifting up the door bin, push it forward and disassemble.	
<b>Shelf (Common to R- and F-Room)</b>	1. Hold the shelf with one hand and lift the rear up with the other hand, and pull it forward.	
<b>Drawer (Common to R- and F-Room)</b>	1. To remove, gently lift up the front of the drawer and slide out. We recommend that you remove the door bins before removing the drawer. This is to prevent damage to the door bins.	



# FULL DISASSEMBLY AND ASSEMBLY

## 3-4) Ice Maker



Part Name	How To Do	Descriptive Picture
Ice Maker	1. Remove the drawer from the freezer.	
	2. Remove 2 ice maker cover screw.	
	3. Detach the cover by pulling it forward.	
	4. Remove 2 ice maker screw.	
	5. Remove the Ice-Maker by separating the housing.	

# FULL DISASSEMBLY AND ASSEMBLY

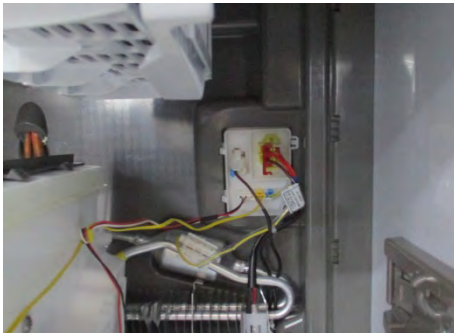

## 3-5) DAMPER

Part Name	How To Do	Descriptive Picture
<b>ASSY COVER EVAP Free zer (FRE)</b>	1. Remove The left and right screws.	
	2. Pull out the bottom.	
	3. Remove the right upper housing.  <b>NOTE</b> When reassembling, inserted it into the upper groove and press the hook.	

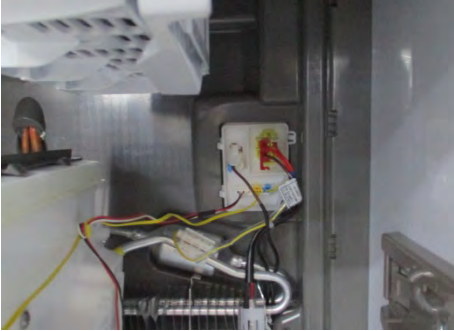
# FULL DISASSEMBLY AND ASSEMBLY

Part Name	How To Do	Descriptive Picture
<b>ASSY COVER EVAP Conversion (FRE)</b>	1. Remove The left and right screws.	
	2. Pull out the bottom.	
	3. Remove the right upper housing.  <b>NOTE</b> When reassembling, inserted it into the upper groove and press the hook.	

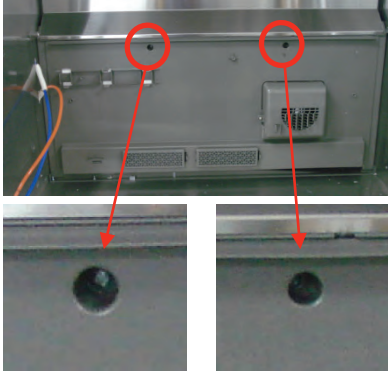
# FULL DISASSEMBLY AND ASSEMBLY

Part Name	How To Do	Descriptive Picture
<b>ASSY COVER EVAP Fridge(REF)</b>	1. Remove the top two screws.	
	2. Pull out the bottom.	
	3. Remove the left two housing.  <b>NOTE</b> When reassembling, set it in the lower drain groove, and then assemble it by pressing the side hook and upper.	

# FULL DISASSEMBLY AND ASSEMBLY

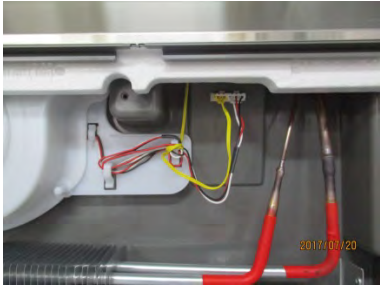
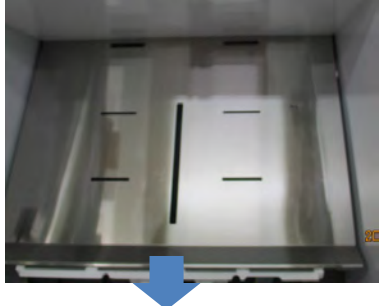
Part Name	How To Do	Descriptive Picture
<b>ASSY COVER EVAP Fridge(REF)</b>	1. Remove The right bottom housing.	
	2. Pull out the bottom.  <b>NOTE</b> When reassembling, inserted it into the upper groove and press the hook.	

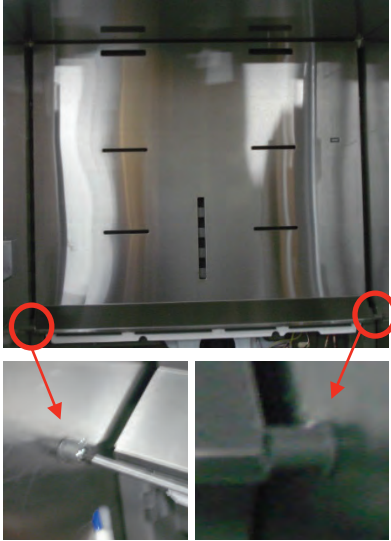
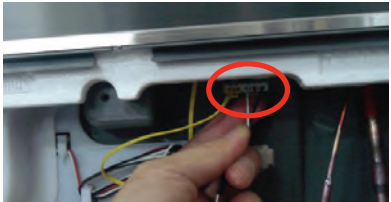
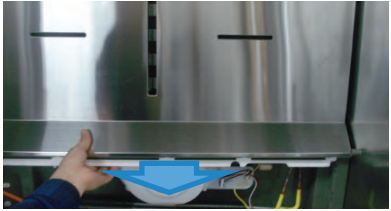

# FULL DISASSEMBLY AND ASSEMBLY

Part Name	How To Do	Descriptive Picture
<b>ASSY COVER MULTI Fridge (REF)</b>	1. Remove both bosses supporting the drawer shelf.	
	2. Remove the right bottom housing.	
	3. Pull out the bottom.  <b>NOTE</b> When reassembling, inserted it into the upper groove and press the hook.	



# FULL DISASSEMBLY AND ASSEMBLY

## 3-6) Case Water Filter

Part Name	How To Do	Descriptive Picture
<p><b>Case Water Filter</b></p>	<p>① Open the filter on the lower part of the product.</p> <p>② Remove 2 Screws on the left side of the filter.</p> <p>③ Detach the front cover of the machine room.</p> <p>④ Remove 2 filter set screws.</p> <p>⑤ Remove water supply hose fitting1.</p> <p>⑥ Remove the filter case.</p> <p>⑦ Remove water valve housing.</p>	



# FULL DISASSEMBLY AND ASSEMBLY

## 3-7) HINGE COVER

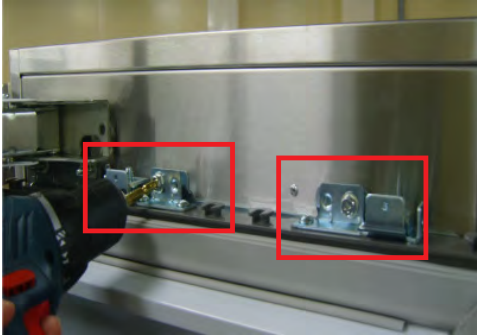

Part Name	How To Do	Descriptive Picture
<b>HINGE COVER</b>	1. Put a (-) screwdriver in between the cover and the hinge and then lift the cover.	
	2. Hold the cover hinge by hand, pull it off.	

# FULL DISASSEMBLY AND ASSEMBLY

## 3-8) Door

Part Name	How To Do	Descriptive Picture
<b>DOOR (REF)</b>	1. Open the fridge door. Disassemble the cap door up and low to pull arrow direction.	
	2. Remove bolts and nuts on Door top and bottom.	
	3. Lift and disassemble the custom panel.	
	4. Remove hinge bolts on Door top and bottom.	

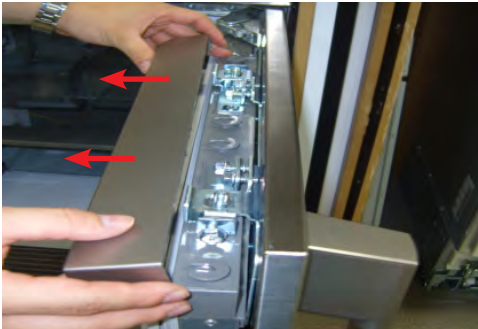
# FULL DISASSEMBLY AND ASSEMBLY

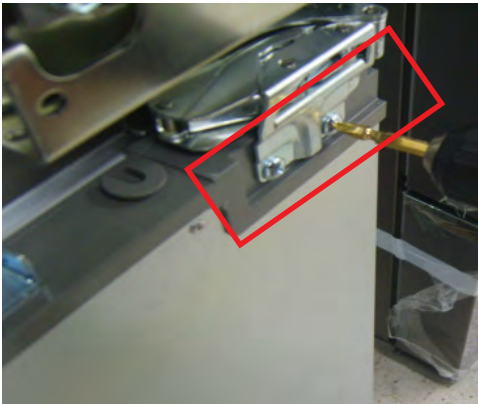
Part Name	How To Do	Descriptive Picture
<b>DOOR (FRE)</b>	1. Open the freezer door. Disassemble the cap door up and low to pull arrow direction.	
	2. Remove bolts and nuts on Door top and bottom.	
	3. Lift and disassemble the custom panel.	
	4. Remove hinge bolts on Door top and bottom.	

# FULL DISASSEMBLY AND ASSEMBLY

## 3-9) Unit

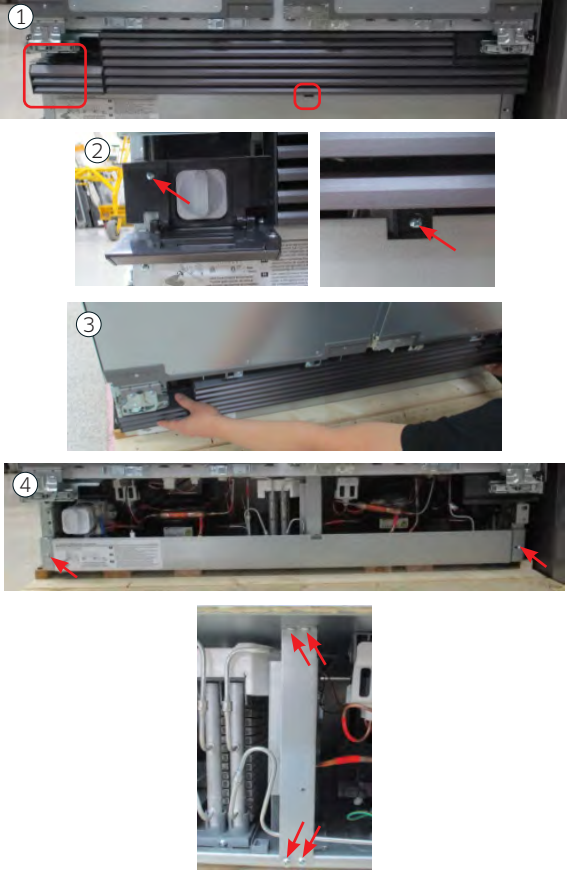
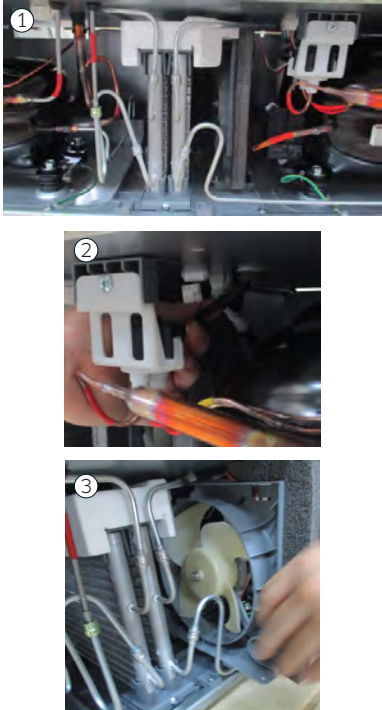
Part Name	How To Do	Descriptive Picture
<p><b>Unit</b></p>	<ol style="list-style-type: none"> <li>① Open the door.</li> <li>② open the cover of the grille and remove two screws indicated with arrow mark.</li> <li>③ Pull left and right side of the grille. Then the grille will be removed.</li> <li>④ Remove two screws of the cover (kick plate) indicated with the arrow mark.</li> </ol>	
<p><b>CONDENSER FAN MOTOR</b></p>	<ol style="list-style-type: none"> <li>① Remove the screw indicated with arrow mark.</li> <li>② Disassemble the housing of the fan from the loop.</li> <li>③ Pull the fan from the unit.</li> </ol>	



# FULL DISASSEMBLY AND ASSEMBLY

Part Name	How To Do	Descriptive Picture
<b>COVER RELAY</b>	<ol style="list-style-type: none"> <li>① Remove the Screw and Pull out Assy case filter(you should prepare plate to spill some water in the filter)</li> <li>② Remove the screw of Step valve and move Step valve to right(Prevent the break of Pipe)</li> <li>③ Disassemble the Cover Relay from Compressor</li> </ol>	
<b>TRAY DRAIN WATER</b>	<p>To replace the tray, the refrigerator set must be serviced separately from the built-in furniture shelf.</p>	

# FULL DISASSEMBLY AND ASSEMBLY







## 3-10) Case water filter & Water valve

Part Name	How To Do	Descriptive Picture
<p><b>CASE WATER FILTER &amp; WATER VALVE</b></p>	<ol style="list-style-type: none"> <li>① Open the filter on the lower part of the product.</li> <li>② Remove 2 Screws on the left side of the filter.</li> <li>③ Detach the front cover of the machine room.</li> <li>④ Remove 2 filter set screws.</li> <li>⑤ Remove water supply hose fitting1.</li> <li>⑥ Remove the filter case.</li> <li>⑦ Remove water valve housing.</li> </ol>	

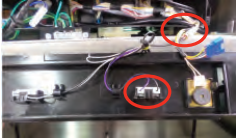
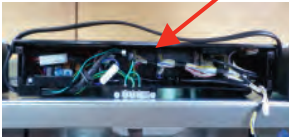

# FULL DISASSEMBLY AND ASSEMBLY

## 3-11) PCB Box

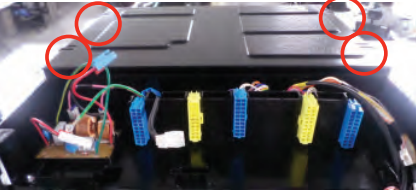
Part Name	How To Do	Descriptive Picture
<b>Top-table</b>	① Disassemble the Top-Table	① 
	② Unscrew Cover-Front screws (4 units) ③ Disassemble the Reed switch / buzzer connector	②  ③ 
	④ Disassemble the Cover-Front Up	④ 
<b>Pcb Box</b>	⑤ Disassemble the connector	⑤ 
	⑥ Remove and unscrew Earths (3 units) and Screws (2 units)	⑥ 
	⑦ Disassemble the PCB box	⑦ 
	⑧ Unscrew the setscrews of the PCB box (4 units)	⑧ 

# FULL DISASSEMBLY AND ASSEMBLY

Part Name	How To Do	Descriptive Picture
<b>WIFI MODULE Box</b>	① Unscrew Cover screw. (1 unit)	
	② Disassemble Cover.	

# FULL DISASSEMBLY AND ASSEMBLY

## 3-12) Procedure of Service lokring

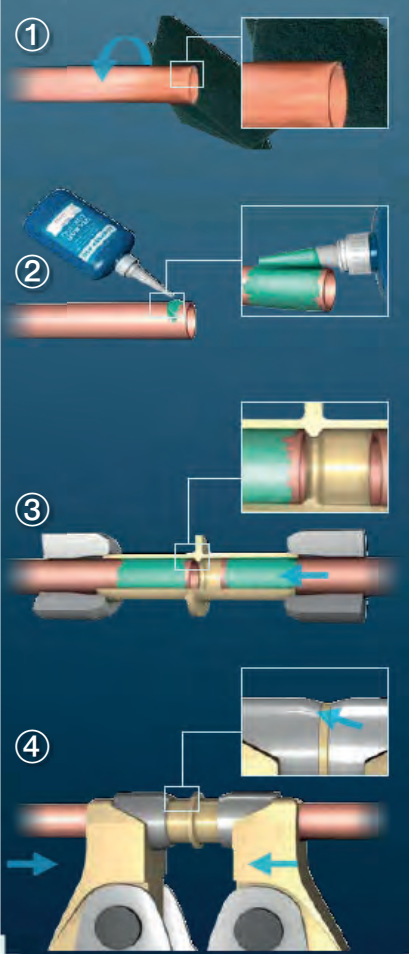
Part Name	How To Do	Descriptive Picture
<b>Procedure of Service lokring</b>	<ol style="list-style-type: none"><li>① Use sand paper to remove foreign matter from the area to be bonded.</li><li>② Apply Lokprep evenly over the joint. (The required amount is about 1 g)</li><li>③ Use the SVC Lokring that meets the pipe standard, and push the pipe to the end.</li><li>④ Using the hand tool, slide the ring to the side where the center of the ring is abutted.</li></ol>	 <p>The diagram illustrates the four steps of the service lokring procedure. Step 1 shows a pipe being sanded with a green sandpaper. Step 2 shows a blue applicator applying a green adhesive (Lokprep) to the pipe's end. Step 3 shows the pipe being pushed into a sleeve, with a yellow Lokring being positioned at the joint. Step 4 shows a yellow hand tool being used to slide the Lokring to the side, where the center of the ring is abutted against the pipe.</p>

# FULL DISASSEMBLY AND ASSEMBLY

## 3-13) Evap

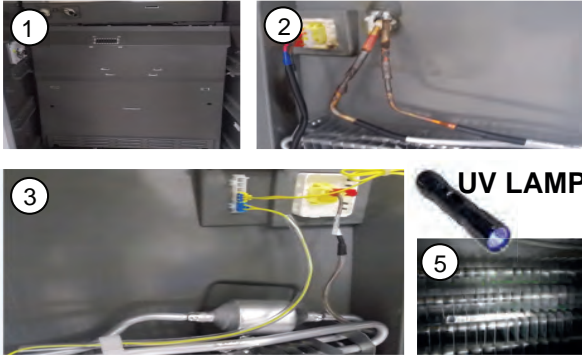
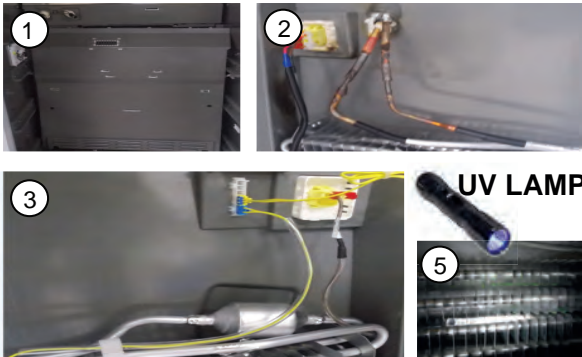
Part Name	How To Do	Descriptive Picture
<p><b>Freezer</b></p>	<ol style="list-style-type: none"> <li>① Open Duct first</li> <li>② Remove Harness and Cut The pipe</li> <li>③ Remove harness of Heater and sensor from Liner.</li> <li>④ Change the Evap and connect pipe with SVC LOKRING</li> <li>⑤ After operating the refrigerator, use the UV lamp to check for leaks.</li> </ol>	 <p>The descriptive picture for the freezer section consists of five numbered images. Image 1 shows the duct being opened. Image 2 shows the harness being removed and the pipe cut. Image 3 shows the heater and sensor harness being removed from the liner. Image 4 shows the new evaporator pipe being connected to the SVC LOKRING. Image 5 shows a UV lamp being used to inspect for leaks.</p>
<p><b>Fridge (Refrigerator)</b></p>	<ol style="list-style-type: none"> <li>① Open Duct first</li> <li>② Remove Harness and Cut The pipe</li> <li>③ Remove harness of Heater and sensor from Liner.</li> <li>④ Change the Evap and connect pipe with SVC LOKRING</li> <li>⑤ After operating the refrigerator, use the UV lamp to check for leaks.</li> </ol>	 <p>The descriptive picture for the fridge section consists of five numbered images. Image 1 shows the duct being opened. Image 2 shows the harness being removed and the pipe cut. Image 3 shows the heater and sensor harness being removed from the liner. Image 4 shows the new evaporator pipe being connected to the SVC LOKRING. Image 5 shows a UV lamp being used to inspect for leaks.</p>

# FULL DISASSEMBLY AND ASSEMBLY

## 3-14) COMPRESSOR

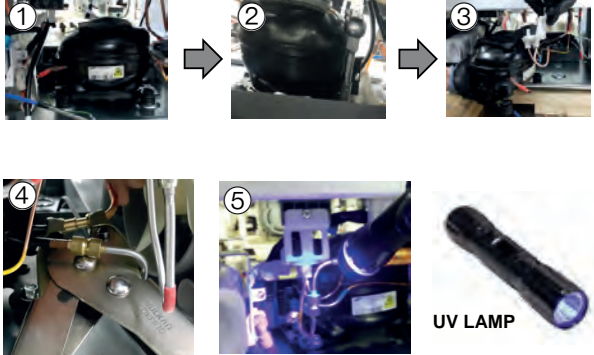
Part Name	How To Do	Descriptive Picture
compressor	<ul style="list-style-type: none"> <li>① Relay cover disassembly</li> <li>② Using wrench bolt</li> <li>③ Replace comp after removing valve</li> <li>④ Connect pipe with SVC lokring</li> <li>⑤ After operating the refrigerator, use the UV lamp to check for leaks.</li> </ul>	 <p>The descriptive picture consists of five numbered steps: 1. A close-up of the relay cover being removed. 2. A wrench being used to turn a bolt. 3. The compressor unit being swapped out. 4. A pipe being connected to a new component using a lokring. 5. A UV lamp being used to illuminate the system for leak detection. A separate image of a black UV lamp is labeled 'UV LAMP'.</p>

<p>※ <b>Notice</b></p>	<p>When Lokring(Welding) service, smell may be transferred to water, so do not detach the filter, remove the entire assembly and service.</p>
------------------------	---



# FULL DISASSEMBLY AND ASSEMBLY

## 3-15) FRENCH

Part Name	How To Do	Descriptive Picture
French	<p>① Separate the screw that has fixed the french.</p> <p>② Hold the French with both hands and put it in a vertical direction.</p> <p>③ Separate the housing connected to the French.</p> <p><b>NOTE</b> The French here refers to the part that looks like a long stick between the left and right fridge doors. (It prevents cold from escaping through the gap between the left and right doors.)</p>	 <p>The descriptive picture consists of three numbered photographs. Photo 1 shows a close-up of a screw being removed from the top of the French door seal. Photo 2 shows a person holding the French door seal vertically. Photo 3 shows a person separating the housing connected to the French door seal.</p>

# FULL DISASSEMBLY AND ASSEMBLY

## 3-16) COVER LAMP

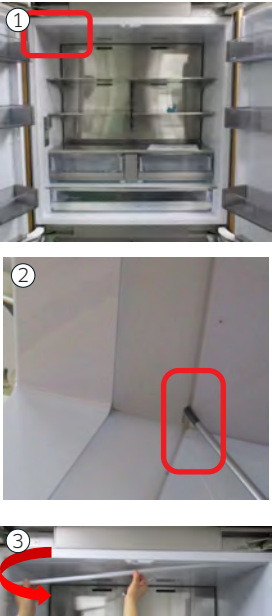
Part Name	How To Do	Descriptive Picture
<p><b>Cover Lamp Side</b></p>	<p>① Separate the COVER LAMP UP.</p> <p>② Separates side COVER LAMP by pulling to direction of an arrow using 'ㄱ' wrench.</p>  <p>③ Assembly order is to assemble at the side first and then to assemble at the top.</p> <p>※ Assembly method is equal to COVER LAMP method at the top.</p>	
<p><b>Cover Lamp Upper</b></p>	<p>① Separates to direction of an arrow by putting '-' driver in separation groove of upper side COVER LAMP UP.</p> <p>※ Separation groove is located in SET upper left back sides.</p> <p>※ Be careful injection molding SCRATCH when separating using 'ㄱ' wrench.</p> <p>② Separates COVER LAMP by pulling with hand slowly to direction of an arrow.</p> <p>③ After set the rib of cover lamp to the left end of the cover lamp, insert it into the internal mounting groove and then assemble it by pushing it to the right.</p>	

# 4. TROUBLESHOOTING

## 4-1) Function for failure diagnosis

### 4-1-1. Test Function (Forced Operation/ Forced Defrost Function)

1. When pressing both the "Control Lock" and "Freezer" keys for more than 5 seconds on PANEL PCB, the PANEL DISPLAY will be ALL ON/OFF at an interval of 0.5 sec. By leaving "control Lock" KEY and "Freezer" KEY and selecting "Control Lock" KEY at this moment, TEST MODE will be activated.
2. In the TEST MODE, every key on the Panel will function as a TEST KEY TEST MODE.
3. TEST Function changes as the TEST KEY is pressed in the following order: Forced Operation1 (FF) → Forced Operation (Fr) → Forced Operation 3(FF F) → Forced Operation 4(FF C) → Forced Operation 5(FF A) → Forced Defrost(Fd) → Cancel (Normal Operation) → Forced Operation1(FF) ...
4. The recommended way to cancel the TEST Function while running the function is to turn the power off and on.

#### (1) Test Mode Entering Process

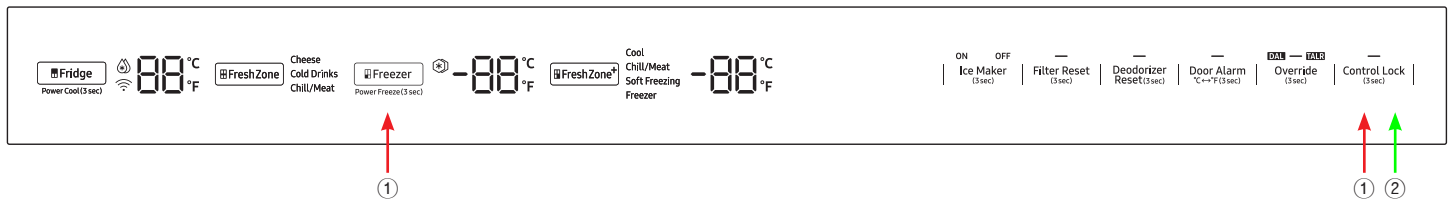

#### (2) Test Mode Function Explanation

##### 1) Forced Operation1



- 1-1) Pressing any KEY once in the TEST MODE will activate the Forced Operation1 function. When the Forced Operation function is activated, PANEL DISPLAY will show 'FF' on the 7-segment to indicate the Forced Operation status. At this moment, BUZZER will BEEP as an alarm.
- 1-2) When Forced Operation1 is selected, the F-COMP. operates instantly without any delay in any Operation MODE. If defrosting, Defrost will be stopped instantly, and Forced Operation will be activated. (Attention: If Forced Operation is activated immediately after COMP OFF time, it may cause OVER-LOAD)

DISPLAY	Operating Time	Operation				
		F-Valve	CV-Valve	F-Fan (Freezer)	CV-Fan (FreshZone+)	R-Fan (Fridge)
FF	24 hours	Swing	Swing	Continuous operation	- Freezer: Continuous operation - else: The temperature is controlled	The temperature is controlled

- \* When the Forced Operation is selected, the freezer compartment will select -23°C(-8°F) automatically.
- \* When Forced Operation is activated, Power Freeze function does not work. (Every KEY is entered normally)  
When the Power Function is selected, the selected Power Function will turn off in ten seconds automatically
- \* When Forced Defrost or Test Cancellation is selected within a minute after Forced Operation is selected, The set temperature will return to the previous set temperature.
- \* The beep sounds of Forced Operation continue until the Operation is complete. There is no deactivate function.



# TROUBLESHOOTING

## 2) Forced Operation2



- 2-1) Pressing any KEY twice in the TEST MODE will activate Forced Operation2 function. When the Forced Operation function is activated, PANEL DISPLAY will show 'Fr' on the 7-segment to indicate the Forced Operation status. At this moment, BUZZER will BEEP as an alarm.
- 2-2) When Forced Operation2 is selected, the F & R-COMP. operates instantly without any delay in any Operation MODE. If defrosting, Defrost will be stopped instantly, and Forced Operation will be activated. (Attention: If Forced Operation is activated immediately after COMP OFF time, it may cause OVER-LOAD)

DISPLAY	Operating Time	Operation				
		F-Valve	CV-Valve	F-Fan (Freezer)	CV-Fan (FreshZone+)	R-Fan (Fridge)
Fr	24 hours	Swing	Swing	Continuous operation	- Freezer : Continuous operation - else : The temperature is controlled	Continuous operation

## 3) Forced Operation3

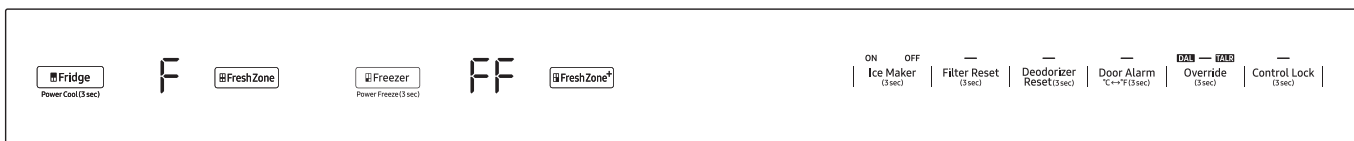

- 3-1) Pressing any KEY three times in the TEST MODE will activate Forced Operation3 function. When the Forced Operation function is activated, PANEL DISPLAY will show 'FF F' on the 7-segment to indicate the Forced Operation status. At this moment, BUZZER will BEEP as an alarm.
- 3-2) When Forced Operation3 is selected, the F-COMP. operates instantly without any delay in any Operation MODE. If defrosting, Defrost will be stopped instantly, and Forced Operation will be activated. (Attention: If Forced Operation is activated immediately after COMP OFF time, it may cause OVER-LOAD)

DISPLAY	Operating Time	Operation				
		F-Valve	CV-Valve	F-Fan (Freezer)	CV-Fan (FreshZone+)	R-Fan (Fridge)
FF F	24 hours	OPEN	CLOSE	Continuous operation	OFF	The temperature is controlled

# TROUBLESHOOTING

## 4) Forced Operation4

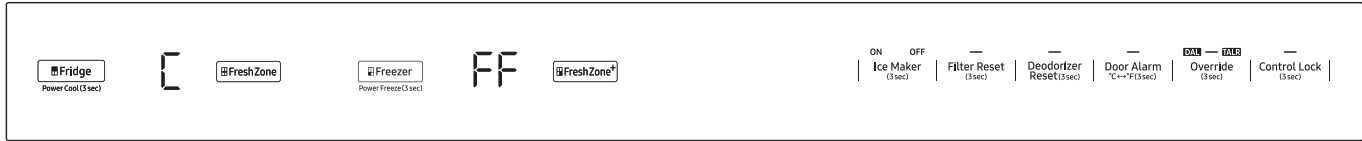

- 4-1) Pressing any KEY four times in the TEST MODE will activate Forced Operation4 function. When the Forced Operation function is activated, PANEL DISPLAY will show 'FF C' on the 7-segment to indicate the Forced Operation status. At this moment, BUZZER will BEEP as an alarm.
- 4-2) When Forced Operation4 is selected, the F-COMP. operates instantly without any delay in any Operation MODE. If defrosting, Defrost will be stopped instantly, and Forced Operation will be activated. (Attention: If Forced Operation is activated immediately after COMP OFF time, it may cause OVER-LOAD)

DISPLAY	Operating Time	Operation				
		F-Valve	CV-Valve	F-Fan (Freezer)	CV-Fan (FreshZone+)	R-Fan (Fridge)
FF C	24 hours	CLOSE	OPEN	OFF	Continuous operation	The temperature is controlled

## 5) Forced Operation5



- 5-1) Pressing any KEY five times in the TEST MODE will activate Forced Operation5 function. When the Forced Operation function is activated, PANEL DISPLAY will show 'FF A' on the 7-segment to indicate the Forced Operation status. At this moment, BUZZER will BEEP as an alarm.
- 5-2) When Forced Operation5 is selected, the F-COMP. operates instantly without any delay in any Operation MODE. If defrosting, Defrost will be stopped instantly, and Forced Operation will be activated. (Attention: If Forced Operation is activated immediately after COMP OFF time, it may cause OVER-LOAD)

DISPLAY	Operating Time	Operation				
		F-Valve	CV-Valve	F-Fan (Freezer)	CV-Fan (FreshZone+)	R-Fan (Fridge)
FF A	24 hours	OPEN	OPEN	Continuous operation	Continuous operation	The temperature is controlled

# TROUBLESHOOTING

## 6) Forced Defrost Function



- 6-1) If any Key is pressed when Forced Operation 5 is activated, Forced Operation 5 will immediately deactivate and switch to Forced Defrost function.  
When the Forced Defrost function is activated, PANEL DISPLAY will show 'Fd' to indicate the Forced Defrost status.  
When Forced Defrost is activated, the alarm will BEEP for 3 seconds.  
After the first three seconds, during Forced Defrost Function, the alarm will BEEP continuously (0.5sec ON/ 0.5sec OFF).

## 7) Test Cancellation Mode.

- 7-1) When the Forced Defrost is activated, if DISPLAY PANEL is switched into the TEST MODE and TEST button is pressed one more time, Forced Defrost will be canceled and will return to the normal operation.  
Or, all the TEST functions will be canceled by turning the MAIN POWER OFF and ON.

# TROUBLESHOOTING

## 4-1-2. Self-diagnosis function

### 1) Self-diagnosis function with the initial POWER ON

- 1-1) When the refrigerator is powered on for the first time, MICOM internally operates a selfdiagnosis function to check the temperature sensors in a few seconds.
- 1-2) If a defective sensor is detected, "all the relevant DISPLAY LED" will blink at intervals of 0.5 sec. There will be no beep sound at this moment. (Refer to the self-diagnose CHECK LIST)
- 1-3) When the self-diagnostic error message is displayed due to a defective sensor, only the selfdiagnose button will be recognized and Display will not operate normally while temperature control will be controlled under the emergency operation.
- 1-4) When a self-diagnosis indicates an ERROR, either fix the defective sensor, or press the Freezer KEY and Control Lock KEY for 10 seconds to automatically deactivate the initial self-diagnose function.





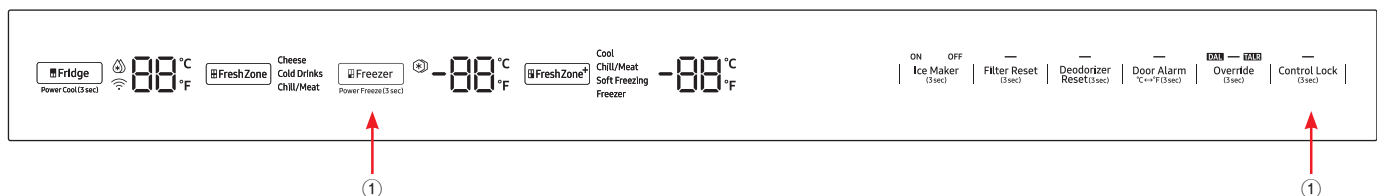











### 2) Self-diagnosis function during normal operation

- 2-1) If the Freezer KEY and Control Lock KEY are pressed for 10 seconds during normal operation, the Self-diagnosis function will be selected with a beep sound.
- 2-2) When initiating the self-diagnosis function, the entire LED will turn off. If there is an error, the indication of the error will be displayed for 60 seconds and then restored to the normal status whether the error is fixed or not. (Refer to the Self-Diagnosis Checklist below)
- 2-3) During the self-diagnosis, button input will not be recognized.













# TROUBLESHOOTING







## ※ Self-diagnosis CHECK LIST

Error	Freezer Display	Fridge Display	Trouble contents	Diagnostic method	Picture
F-Sensor Error	1		C Slipped out Sensor Housing, Wire-Cut, Wire-Short, When the sensor pickup temp is over +50 °C or under -50 °C, Error occurs.	The voltage between Case Connector DC YEL1 #5 ↔ #6 should be within 4.5V~1.0V	 
R-Sensor Error	2			The voltage between Case Connector DC YEL2 #16 ↔ #17 should be within 4.5V~1.0V	 
F-Def Sensor Error	4			The voltage between Case Connector DC BLU1 #14 ↔ #15 should be within 4.5V~1.0V	 
R-Def Sensor Error	5			The voltage between Case Connector DC YEL2 #14 ↔ #15 should be within 4.5V~1.0V	 
Ambient Sensor Error	6			The voltage between HINGE CONNECTOR #2 ↔ #3 should be within 4.5V~1.0V	 
Pantry Sensor Error	7			The voltage between Case Connector DC BLU1 #16 ↔ #17 should be within 4.5V~1.0V	 
Ice Maker Sensor Error	8			The voltage between Case Connector DC BLU1 #4 ↔ #5 should be within 4.5V~1.0V	 
CV-Sensor Error	9				 

# TROUBLESHOOTING



Error	Freezer Display	Fridge Display	Trouble contents	Diagnostic method	Picture	
CV-Def Sensor Error	11	C	Slipped out Sensor Housing, Wire-Cut, Wire-Short, When the sensor pickup temp is over +50 °C or under -50 °C, Error occurs.			
Ambient-Humidity Sensor Error	13				The voltage between HINGE CONNECTOR #2 ↔ #4 should be within 4.5V~1.0V	
R-Humidity Sensor Error	16		Slipped out Sensor Housing, Wire-Cut, Wire-Short, When the sensor pickup temp is over +50 °C or under -50 °C, Error occurs.	The voltage between Case Connector DC WHT #1 ↔ #2 should be within 4.5V~1.0V		
F-Fan Error	21			The voltage between Case Connector DC BLU1 #3 ↔ #4 should be within 7V~12V		
R-Fan Error	22		When the related Fan Motor operates, it occurs if the contact of the Feed Back Signal Wire is defective, the Motor Wire is slipped out or the Motor is defective	The voltage between Case Connector DC YEL2 #19 ↔ #20 should be within 7V~12V		
C-Fan Error	23			The voltage between Case Connector DC WHT #14 ↔ #15 should be within 7V~12V		

# TROUBLESHOOTING

Error	Freezer Display	Fridge Display	Trouble contents	Diagnostic method	Picture
F-Defrost Error	24	C	Separation of freezer compartment defrost heater housing part, contact error, disconnection, short circuit or temperature fuse error. Display error : the defrosting does not finish though freezer compartment defrost is heating continuously for more than 120 minutes.	After separating AC RED connector, resistance value between AC RED 4 ↔ 5 shall be 63(230) ohm ± 7%. (Resistance value is varied by input power) 0 ohm : heater short, ∞ ohm : wire/ bimetal open (Must power off)	 
Ice Maker Function Error	26		When the Ice Maker error occurs more than 3 times, the error will be displayed.	After changing the Ice Maker(R), plug the refrigerator power code again, and check the operation.	 
CV-Defrost Error	29		The separation of the FreshZone+ compartment defrosting heater housing part, contact error, disconnection, short circuit or temperature fuse error. One of these error codes is displayed if the defrosting operation of the FreshZone+ does not finish even after the continuous heating operation has been performed for 120 minutes.		 



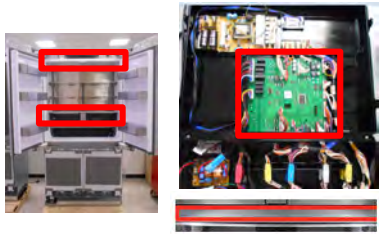
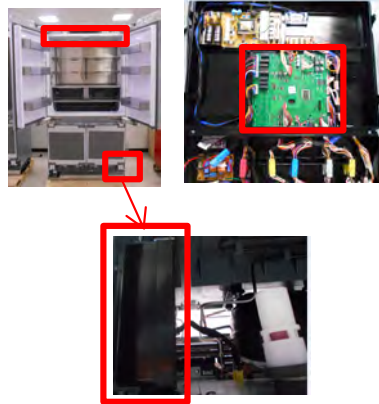
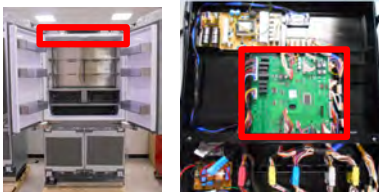

# TROUBLESHOOTING

Error	Freezer Display	Fridge Display	Trouble contents	Diagnostic method	Picture
CV-Fan Error	31		When the related Fan Motor operates, it occurs if the contact of the Feed Back Signal Wire is defective, the Motor Wire is slipped out or the Motor is defective		
Ice Maker Ice Pipe Heater Error	33		Display error when open error is detected by Heater : separation of Ice Pipe Heater housing part, contact error, disconnection, short circuit.	After separating DC YEL1 Connector, resistance value between DC YEL1 14↔17 wire shall be 135 ohm± 7%. 0 ohm : heater short, ∞ Ohm : wire.	
Communication Error between Main ↔ Panel	41	C	When there is no communication between MICOM MAIN ↔ PANEL for more than 10 seconds, the MICOM MAIN ↔ PANEL Communication Error Window will show on the Display.	To check its defect, a Oscilloscope is needed. So, replace the MAIN PCB and check if the problem persists.	
Communication Error between Main ↔ F-Comp Inverter	44		Display 44Er in the panel : F-Inverter MICOM ↔ Main MICOM communication error.	Actually, If there is not a problem, it is desirable to replace Main and F-Comp Inverter PCB With the oscilloscope after a cable problem confirming.	
Communication Error between Main ↔ R-Comp Inverter	45		Display 45Er in the panel : R-Comp Inverter MICOM ↔ Main MICOM communication error.	Actually, If there is not a problem, it is desirable to replace Main and R-Comp inverter PCB With the oscilloscope after a cable problem confirming.	

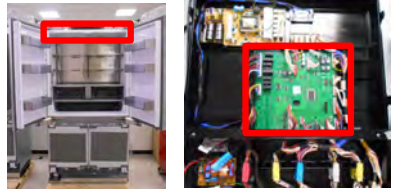

# TROUBLESHOOTING

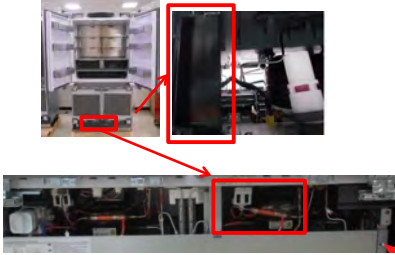
Error	Freezer Display	Fridge Display	Trouble contents	Diagnostic method	Picture
Communication Error between Main ↔ I/O Expander	46		Display 46Er in the panel : I/O Expander ↔ Main MICOM communication error.	It is desirable to replace Main PCB.	
FRESHZONE FAN Error	62		When the related Fan Motor operates, it occurs if the contact of the Feed Back Signal Wire is defective, the Motor Wire is slipped out or the Motor is defective.	The voltage between Case Connector DC BLU1 #19 ↔ #20 should be within 7V~12V	
Abnormal High Temperature of Freezer	71	C	The error occurs when the Freezer temperature rises abnormally or when the Freezer Door remains open for a while while the unit's inside temperature is high.	When its Door remains open for an extended time or high temperature food is stored, close the Door or take out the hot food. Then, after a while, the error will disappear.	
Abnormal High Temperature of Fridge	72		The error occurs when the Fridge temperature rises abnormally or when the Fridge Door remains open for a while while the unit's inside temperature is high.		
Abnormal High Temperature of FreshZone+	73		The error occurs when the FreshZone+ temperature rises abnormally or when the Fridge Door remains open for a while while the unit's inside temperature is high.	When its Door remains open for an extended time or high temperature food is stored, close the Door or take out the hot food. Then, after a while, the error will disappear.	

# TROUBLESHOOTING

Error	Freezer Display	Fridge Display	Trouble contents	Diagnostic method	Picture
F-Comp Startup Failure	81	C	When the Comp Startup Failure is detected	<ol style="list-style-type: none"> <li>1. Short between Comp. U/V/W (CN04)</li> <li>2. Short between IPM PIN (#1~26)</li> </ol>	
F-Comp IPM Fault Error	82		When the F-Comp IPM Fault is detected		
Abnormal Current Pick-Up at F-Comp	83		When the Abnormal Current is pick-up at the F-Comp	<ol style="list-style-type: none"> <li>1. Comp Connector Plugged Out (CN04)</li> <li>2. R1 Defect or Assembly Defect</li> <li>3. Check Comp and Cycle</li> </ol>	
F-Comp Motor Restriction	84		When the F-Comp Motor Restriction is detected	<ol style="list-style-type: none"> <li>1. When the Comp is restricted for more than 5 seconds</li> <li>2. When the Comp runs at lower than 1000RPM for over 5 seconds</li> <li>3. R1 Short</li> <li>4. Severe fluctuation of Input Voltage</li> <li>5. Check Comp and Cycle</li> </ol>	
F-Comp Low Voltage	85		When the Low Voltage is detected at the F-Comp	<ol style="list-style-type: none"> <li>1. Input AC Voltage 106V or lower</li> <li>2. When R312 is short (DC Link Resistor)</li> </ol>	
F-Comp High Voltage	86		When the High Voltage is detected at the F-Comp	<ol style="list-style-type: none"> <li>1. Input AC Voltage 310V or higher</li> <li>2. When R309, R310 or R311 is short (DC Link Resistor)</li> </ol>	

# TROUBLESHOOTING

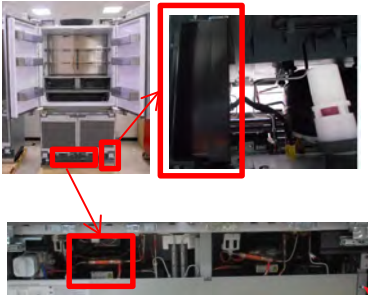
Error	Freezer Display	Fridge Display	Trouble contents	Diagnostic method	Picture
R-Comp Startup Failure	87	C	When the Comp Startup Failure is detected	1. Short between Comp. U/V/W (CN04) 2. Short between IPM PIN (#1~26)	
R-Comp IPM Fault Error	88		When the R-Comp IPM Fault is detected	3. IPM Operation Voltage Dropdown (Lower than DC13.5V) 4. Check Comp and Cycle	
Abnormal Current Pick-Up at R-Comp	89		When the Abnormal Current is pick-up at the R-Comp	1. Comp Connector Plugged Out (CN04) 2. R1 Defect or Assembly Defect 3. Check Comp and Cycle	
R-Comp Motor Restriction	90		When the R-Comp Motor Restriction is detected	1. When the Comp is restricted for more than 5 seconds 2. When the Comp runs at lower than 1000RPM for over 5 seconds 3. R1 Short 4. Severe fluctuation of Input Voltage 5. Check Comp and Cycle	
R-Comp Low Voltage	91		When the Low Voltage is detected at the R-Comp	1. Input AC Voltage 106V or lower 2. When R312 is short (DC Link Resistor)	
R-Comp High Voltage	92		When the High Voltage is detected at the R-Comp	1. Input AC Voltage 310V or higher 2. When R309, R310 or R311 is short (DC Link Resistor)	

# TROUBLESHOOTING

## 4-1-3. Load Condition Display functions

- 1) When the Freezer KEY and Control Lock KEY are simultaneously pressed for about six seconds, PANEL DISPLAY will be ALL ON/OFF at an interval of 0.5 sec. By leaving the Fridge KEY and Control Lock KEY and pressing Fridge KEY at this moment, the display will switch modes to the Load Condition Display Function.
- 2) The Load Condition Display MODE indicates what kind of load is outputting the MICOM signal. However, it only indicates that the MICOM signal is outputted, not whether the load is actually operating. That is, even if it displays that a load is operating. The actual load might not work due to a defective RELAY on PCB, defective load, etc. (Needs to be checked)
- 3) Load Condition Display Function only continues for 30 seconds, and restores the normal mode automatically.

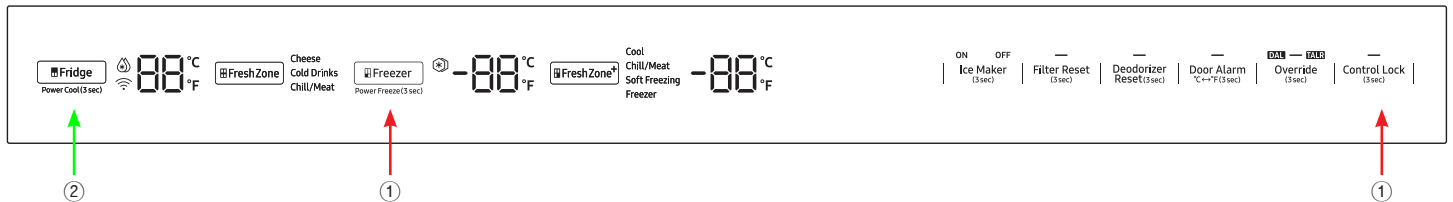

- 4) Relevant Display indication of Load Condition is as follows:

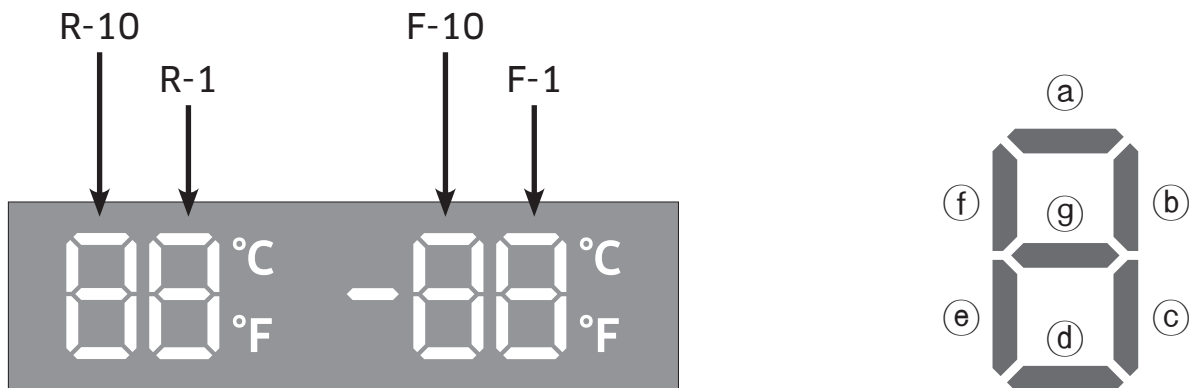

# TROUBLESHOOTING

## ※ Load Mode CHECK LIST

Load Item	DISPLAY LED	Description
R-FAN HIGHEST	R-compartment first letter "a", "b"	Relevant LED will BLINK when R-FAN HIGHEST operates
R-FAN HIGH	R-compartment first letter "a"	Relevant LED will BLINK when R-FAN HIGH operates
R-FAN LOW	R-compartment first letter "b"	Relevant LED will BLINK when R-FAN LOW operates
R-COMP	R-compartment first letter "d"	The relevant LED will BLINK when the R-COMP operates
Overload Condition	R-compartment first letter "e"	When ambient temperature is over 34°C(93.2°F), the relevant LED will BLINK
Low temperature condition	R-compartment first letter "f"	When ambient temperature is under 21°C(69.8°F), the relevant LED will BLINK
Normal condition	R-compartment first letter "e", "f"	When ambient temperature is between 22°C and 33°C, the relevant LED will BLINK
Exhibition Mode	R-compartment first letter "g"	The relevant LED will BLINK under exhibition mode
Ice-Maker heater	R-compartment second letter "c"	The LED BLINK when the Ice Maker heater is activated
Ice-Maker Full Ice Detection.	R-compartment second letter "d"	The LED BLINK when the Ice-maker is full
F-COMP	F-compartment first letter "a"	The relevant LED will BLINK when the F-COMP operates
F-FAN HIGHEST	F-compartment first letter "b", "c"	The relevant LED will BLINK when F-FAN HIGHEST operates
F-FAN HIGH	F-compartment first letter "b"	The relevant LED will BLINK when F-FAN HIGH operates
F-FAN LOW	F-compartment first letter "c"	The relevant LED will BLINK when F-FAN LOW operates
F-compartment defrost heater	F-compartment first letter "d"	The relevant LED will BLINK when F-compartment defrost heater operates
C-FAN HIGHEST	F-compartment first letter "e", "f"	The relevant LED will BLINK when C-FAN HIGHEST operates
C-FAN HIGH	F-compartment first letter "e"	Relevant LED will BLINK when C-FAN HIGH operates
C-FAN LOW	F-compartment first letter "f"	The relevant LED will BLINK when C-FAN LOW operates
F Valve	F-compartment second letter "b"	The relevant LED will BLINK when the F-Valve is open
CV Valve	F-compartment second letter "c"	The relevant LED will BLINK when the CV Valve is open
R Valve	F-compartment second letter "f"	The LED will BLINK when the R Valve is open
FreshZone FAN	F-compartment second first "d"	The LED BLINK when the FreshZone FAN is ON
French Heater	F-compartment second letter "g"	The LED BLINK when the French Heater operates

# TROUBLESHOOTING

Load Item	DISPLAY LED	Description
CV-FAN HIGHEST	"Freezer", "Soft Freeze" for the FreshZone+ compartment	In the case of the CV-FAN HIGHEST operation, the corresponding LED is turned on.
CV-FAN HIGH	"Freezer" for the FreshZone+ compartment	In the case of the CV-FAN HIGH operation, the corresponding LED is turned on.
CV-FAN LOW	"Soft Freeze" for the FreshZone+ compartment	In the case of the CV-FAN LOW operation, the corresponding LED is turned on.
CV compartment defrost heater	"Fridge" for the FreshZone+ compartment	When the CV compartment defrosting heater operates, the LED is turned on.
Wifi condition	Wifi Icon	When not connected to a router or Internet : Off
		When connected to the Internet LED ON

# TROUBLESHOOTING

## 4-1-4. Operation Condition Restore Function For Blackout

- 1) If PANEL DISPLAY is reset by a momentary blackout, consumer's NON-SENSE CALL may occur. To prevent this, when the power is restored, either initialization or Operation Condition Restore will be initiated, depending on the interior temperature.
- 2) With the initial POWER ON, interior temperature and the defrost sensor temperature are checked. If either of the two temperatures are under about +10°C (50°F), judging there was a momentary blackout, functions related to the PANEL DISPLAY (interior temperature settings, Door Alarm, Power Cool, Power Freeze, Ice On/Off setting, etc.) are restored.
- 3) On initial POWER ON, if both interior temperature and defrost sensor temperature are over +10°C (50°F), judging there was a long-term blackout, PANEL DISPLAY is initialized. (Automatically sets -19°C for F-compartment and 3°C for R-compartment.)

## 4-1-5. Cooling Off Setting Function

- 1) Cooling Off mode (also called Shop mode) is designed for use by retailers when they are displaying refrigerators on a retail floor. In Cooling Off mode, the fan motor and lights operate normally, but the compressors do not run so both the refrigerator and the freezer do not get cold.
- 2) To enter Cooling Off mode, press and hold Ice Maker, Filter Reset, and Control Lock simultaneously for 5 seconds. The refrigerator chime sounds and the temperature display flashes "OFF".
- 3) To exit Cooling Off mode, press and hold Ice Maker, Filter Reset, and Control Lock simultaneously for 5 seconds again.

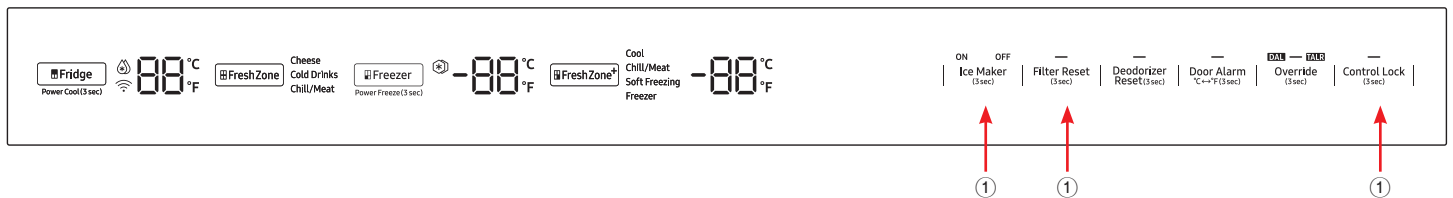

**NOTE** If the Control Lock indicator turns on, you must first deactivate Control Lock.

# TROUBLESHOOTING

## 4-1-6. Display function of Communication error



- 1) Display function when Panel ↔ MAIN MICOM communication has error.
  - 1-1) If there is no answer for 10 seconds after the panel micom received the requirement of communication, "PC" display on the panel PCB will be ON/OFF alternately until the communication error is canceled. (0.5 sec ALL ON, 0.5 sec ALL OFF alternately)
  - 1-2) "PC" display on the Panel Display will be ON/OFF alternately until the communication error is canceled. (0.5 sec ALL ON, 0.5 sec ALL OFF alternately)

## 4-1-7. Entering AP Mode and Samsung Connect Product Registration

- 1) Launch Samsung Connect app, press "+"(add device) button, and select Refrigerator from the product list.
- 2) Follow the directions on the screen, input information of the wire/wireless router to be connected, and press "Next" button. (This step is to connect to the wire/wireless router to register the product, follow the app instructions.)
- 3) Press [Fridge] button for more than five seconds on the display. (After three seconds, Power Cool will be activated, and after two more seconds, Power cool will be deactivated and AP will be displayed.)  
When "AP" is displayed on the temperature display panel, start Easy Connection
- ※ If Easy Connection does not proceed on the smartphone, please try this step again.
- 4) Easy Connection will automatically register the product. When product registration is finished, a refrigerator icon will appear on the app display. (If product registration fails, please try again from the first step.)
- 5) Select registered refrigerator icon.



## 4-1-8. MAC Address Display Mode

- 1) This function displays the MAC Address of the refrigerator Wi-Fi. The MAC address will be alternately displayed on the temperature display panel for a minute.
  - ① If the [Freezer] and [Fridge] buttons are pressed for more than 6 seconds, the Display will blink. Press [Freezer] button at this point, and it will initiate MAC Address Display Mode with a beep sound.
- 2) If MAC address is "11-22-33-44-55-66", it will display "--" → "11" → "22" → ... → "66" → "--" on the display panel for a minute. After a minute, MAC Address Display Function will be deactivated, and switched into the normal display mode.
  - ※ If the MAC address is invalid, or a Wi-Fi module is not connected, "--" will be displayed on the freezer compartment display panel for a minute.

# TROUBLESHOOTING

## 4-1-9. Option Setting Function

- 1) When pressing both the "Control Lock" and "Freezer" keys for more than 5 seconds on PANEL PCB, the PANEL DISPLAY will be ALL ON/OFF at an interval of 0.5 sec. By leaving "Control Lock" KEY and "Freezer" KEY and selecting "Freezer" KEY at this moment, it operates in Option setting mode.
- If there is no KEY input for 20 seconds in Option Setting Mode, it will switch into the normal DISPLAY.

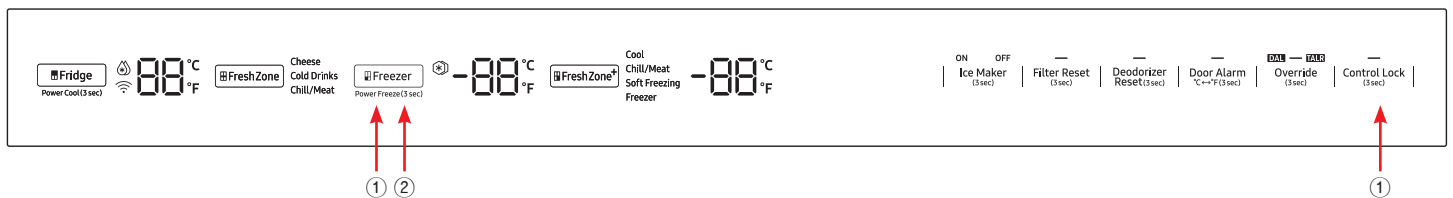

### Option Mode & Key operation Instructions

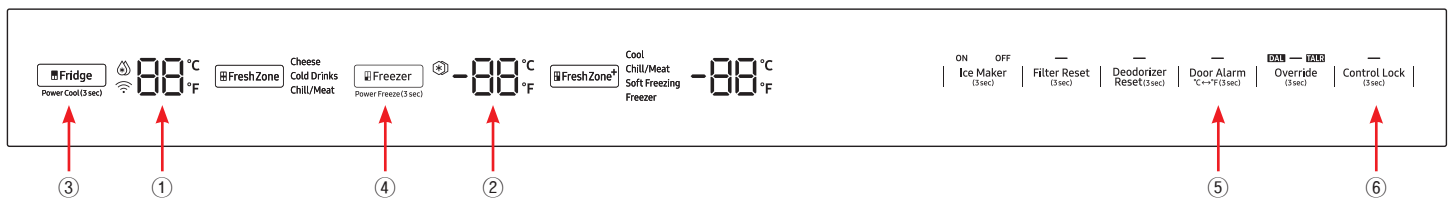

1. Displays selected Option number.
2. Displays the set value of the selected Option.
3. Increase Option number by one level.
4. Decrease the Option number by one level.
5. Increase Option setting value by one level.
6. Decrease Option setting value by one level.

# TROUBLESHOOTING

- When the DISPLAY is switched into the Option Setting MODE every LED except temperature DISPLAY and KEY DISPLAY will be OFF as below.



- 1) For example, if you want to SHIFT the reference temperature of F-compartment to  $-2^{\circ}\text{C}$  ( $-4^{\circ}\text{F}$ ) by changing the operating option, follow the below instructions.  
This function changes the reference temperature. If F-compartment reference temperature is  $-21^{\circ}\text{C}$  ( $-5.8^{\circ}\text{F}$ ), and lowered by  $-2^{\circ}\text{C}$  ( $-4^{\circ}\text{F}$ ) by the option, the reference temperature will be controlled at  $-23^{\circ}\text{C}$  ( $-9.4^{\circ}\text{F}$ ). That is, if you change the temperature setting, even if  $-21^{\circ}\text{C}$  ( $-5.8^{\circ}\text{F}$ ) is set on the panel, The appliance will internally be operated at  $-23^{\circ}\text{C}$  ( $-9.4^{\circ}\text{F}$ ).  
Therefore, it means that the reference temperature is controlled  $-2^{\circ}\text{C}$  ( $-4^{\circ}\text{F}$ ) lower than the set temperature displayed on the panel.

**NOTE** Fundamentally, Every data of the option function is cleared during the shipping process. In other words, every setting value is "0" during the shipping process. However, as some values may change for quality improvement during mass production, Always check quality information, and other related documents.

# TROUBLESHOOTING

2) When switched into the option mode, DISPLAY will show "0" for OPTION numbers and setting values. (Every setting value is supposed to be set to "0" during the shipping process, but the basic setting values may have changed for quality improvement during mass production.)

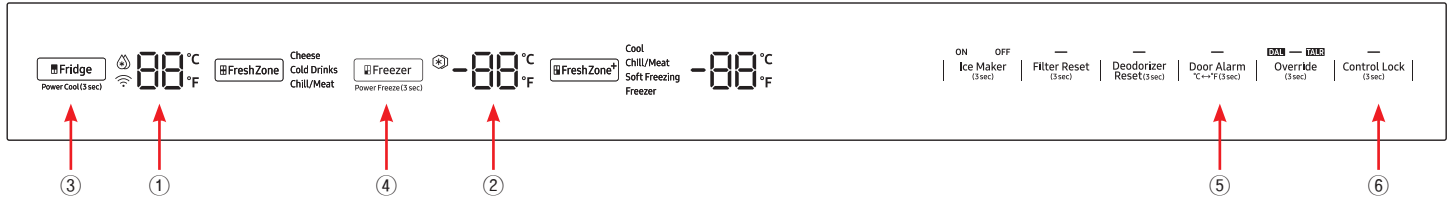

Press number 3 or 4 buttons to set the desired option number.

1) For example, if you want to SHIFT the reference temperature of F-compartment, use number 3 or 4 button to set the option number to 0 as shown below. At this point, if you want to shift  $-2^{\circ}\text{C}$  ( $-4^{\circ}\text{F}$ ), press the number 5 or 6 button to set the value of the Freezer Display to '4'.

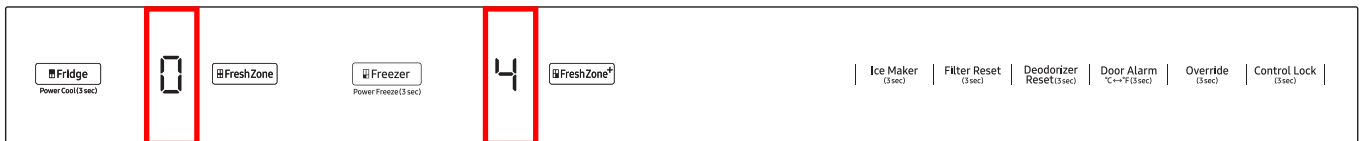

Setting value	Option Value
Freezer Temp Display Panel Set Value	Option Value
0	0.0°C (32.0°F)
1	-0.5°C (31.1°F)
2	-1.0°C (30.2°F)
3	-1.5°C (29.3°F)
4	-2.0°C (28.4°F)
5	-2.5°C (27.5°F)
6	-3.0°C (26.6°F)
7	-3.5°C (25.7°F)
8	+0.5°C (32.9°F)
9	+1.0°C (33.8°F)
10	+1.5°C (34.7°F)
11	+2.0°C (35.6°F)
12	+2.5°C (36.5°F)
13	+3.0°C (37.4°F)
14	+3.5°C (38.3°F)
15	+4.0°C (39.2°F)

# TROUBLESHOOTING

2) For example, if you want to SHIFT the reference temperature of R-compartment, use number 3 or 4 button to set the option number to 1 as shown below. At this point, if you want to shift +1.5°C, press the number 5 or 6 button to set the value of the Freezer Display to '10'.



Setting value	Option Value
Freezer Temp Display Panel Set Value	
0	0.0°C (32.0°F)
1	-0.5°C (31.1°F)
2	-1.0°C (30.2°F)
3	-1.5°C (29.3°F)
4	-2.0°C (28.4°F)
5	-2.5°C (27.5°F)
6	-3.0°C (26.6°F)
7	-3.5°C (25.7°F)
8	+0.5°C (32.9°F)
9	+1.0°C (33.8°F)
10	+1.5°C (34.7°F)
11	+2.0°C (35.6°F)
12	+2.5°C (36.5°F)
13	+3.0°C (37.4°F)
14	+3.5°C (38.3°F)
15	+4.0°C (39.2°F)

# TROUBLESHOOTING

3) For example, if you want to adjust the Ice Maker's water supply rate, use number 3 or 4 button to set the option number to 2 as shown below. At this point, if you want to set the water supply to 120cc, press the number 5 or 6 button to set the value of the Freezer Display to '1'.

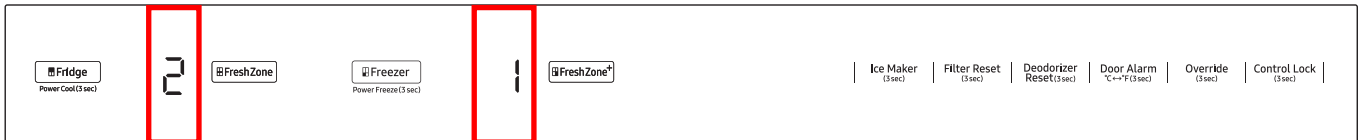

Setting value	Option Value
Freezer Temp Display Panel Set Value	
0	110cc
1	120cc

# TROUBLESHOOTING

4) For example, if you want to adjust Ice Maker's idle time of ice ejection, use number 3 or 4 button to set the option number to 3 as shown below. At this point, if you want to set the idle time to 55 minutes, press the number 5 or 6 button to set the value of the Freezer Display to '4'.



Setting value	Option Value
Freezer Temp Display Panel Set Value	
0	60min
1	47min
2	45min
3	53min
4	55min
5	57min
6	65min
7	70min
8	50min
9	50min
10	50min
11	50min
12	50min
13	50min
14	50min
15	50min

# TROUBLESHOOTING

5) For example, if you want to adjust Ice Maker's ice ejecting temperature, use number 3 or 4 button to set the option number to 4 as shown below. At this point, if you want to set the temperature to -8.0°C, press the number 5 or 6 button to set the value of the Freezer Display to '3'.



Setting value	Option Value
Freezer Temp Display Panel Set Value	
0	-7.5°C (18.5°F)
1	-7.0°C (19.4°F)
2	-6.5°C (20.3°F)
3	-8.0°C (17.6°F)
4	-8.5°C (16.7°F)
5	-9.0°C (15.8°F)
6	-9.5°C (14.9°F)
7	-10.0°C (14.0°F)



# TROUBLESHOOTING

6) For example, if you want to adjust Sub Heater's driving rate, use number 3 or 4 button to set the option number to 19 as shown below. At this point, if you want to add 20% more on the current driving rate, press the number 5 or 6 button to set the value of the Freezer Display to '1'.

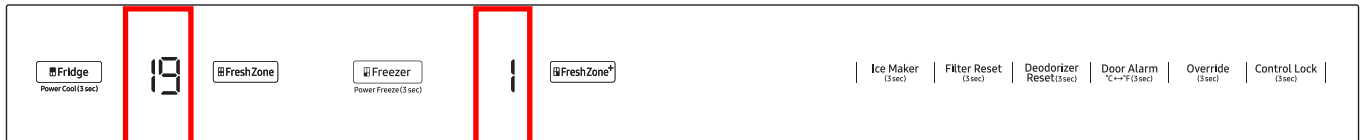

Setting value	Option Value
Freezer Temp Display Panel Set Value	
0	Keep the current control status
1	add 20 percent on the current control status (maximum 100 %)

# TROUBLESHOOTING

7) For example, if you want to SHIFT the reference temperature of FreshZone-compartment, use number 3 or 4 button to set the option number to 20 as shown below. At this point, if you want to shift -3.0°C, press the number 5 or 6 button to set the value of the Freezer Display to '3'.

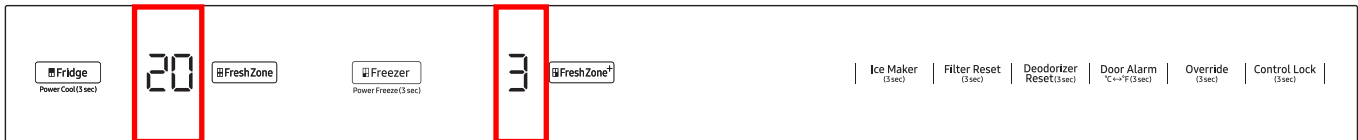

Setting value	Option Value
Freezer Temp Display Panel Set Value	
0	0.0°C (32.0°F)
1	-1.0°C (30.2°F)
2	-2.0°C (28.4°F)
3	-3.0°C (28.4°F)
4	-4.0°C (28.4°F)
5	+1.0°C (33.8°F)
6	+2.0°C (33.8°F)
7	+3.0°C (34.7°F)

# TROUBLESHOOTING

8) For example, if you want to SHIFT the reference temperature of CV-compartment, use number 3 or 4 button to set the option number to 34 as shown below. At this point, if you want to shift +1.5°C, press the number 5 or 6 button to set the value of the Freezer Display to '10'.

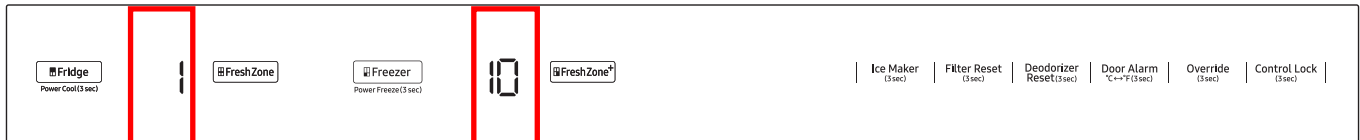

Setting value	Option Value
Freezer Temp Display Panel Set Value	
0	0.0°C (32.0°F)
1	-0.5°C (31.1°F)
2	-1.0°C (30.2°F)
3	-1.5°C (29.3°F)
4	-2.0°C (28.4°F)
5	-2.5°C (27.5°F)
6	-3.0°C (26.6°F)
7	-3.5°C (25.7°F)
8	+0.5°C (32.9°F)
9	+1.0°C (33.8°F)
10	+1.5°C (34.7°F)
11	+2.0°C (35.6°F)
12	+2.5°C (36.5°F)
13	+3.0°C (37.4°F)
14	+3.5°C (38.3°F)
15	+4.0°C (39.2°F)

# TROUBLESHOOTING

## 4-2) Diagnostic method according to the trouble symptom (Flow Chart)

DATA1.Temperature table

Resistance value and MICOM port voltage of sensor according to the temperature

SENSOR CHIP : based on PX41C, PX41C, 502AT/ 103\*\*(ICE MAKER SENSOR(MOLD)/FULL UP, 20Kohm ( Actual measurement = value of the table below X 2 )

°C	°F	Voltage	Resistance	°C	°F	Voltage	Resistance	°C	°F	Voltage	Resistance
-50	-58	4.694	153319	-5	23	3.107	16419	40	104	1.153	2997
-49	-56.2	4.677	144794	-4	24.8	3.057	15731	41	105.8	1.124	2899
-48	-54.4	4.659	136798	-3	26.6	3.006	15076	42	107.6	1.095	2805
-47	-52.6	4.641	129294	-2	28.4	2.955	14452	43	109.4	1.068	2714
-46	-50.8	4.622	122248	-1	30.2	2.904	13857	44	111.2	1.040	2627
-45	-49	4.602	115631	0	32	2.853	13290	45	113	1.014	2543
-44	-47.2	4.581	109413	1	33.8	2.802	12749	46	114.8	0.988	2462
-43	-45.4	4.560	103569	2	35.6	2.751	12233	47	116.6	0.963	2384
-42	-43.6	4.537	98073	3	37.4	2.700	11741	48	118.4	0.938	2309
-41	-41.8	4.514	92903	4	39.2	2.649	11271	49	120.2	0.914	2237
-40	-40	4.490	88037	5	41	2.599	10823	50	122	0.891	2167
-39	-38.2	4.465	83456	6	42.8	2.548	10395	51	123.8	0.868	2100
-38	-36.4	4.439	79142	7	44.6	2.498	9986	52	125.6	0.846	2036
-37	-34.6	4.412	75077	8	46.4	2.449	9596	53	127.4	0.824	1973
-36	-32.8	4.385	71246	9	48.2	2.399	9223	54	129.2	0.803	1913
-35	-31	4.356	67634	10	50	2.350	8867	55	131	0.783	1855
-34	-29.2	4.326	64227	11	51.8	2.301	8526	56	132.8	0.762	1799
-33	-27.4	4.296	61012	12	53.6	2.253	8200	57	134.6	0.743	1745
-32	-25.6	4.264	57977	13	55.4	2.205	7888	58	136.4	0.724	1693
-31	-23.8	4.232	55112	14	57.2	2.158	7590	59	138.2	0.706	1642
-30	-22	4.199	52406	15	59	2.111	7305	60	140	0.688	1594
-29	-20.2	4.165	49848	16	60.8	2.064	7032	61	141.8	0.670	1547
-28	-18.4	4.129	47431	17	62.6	2.019	6771	62	143.6	0.653	1502
-27	-16.6	4.093	45146	18	64.4	1.974	6521	63	145.4	0.636	1458
-26	-14.8	4.056	42984	19	66.2	1.929	6281	64	147.2	0.620	1416
-25	-13	4.018	40938	20	68	1.885	6052	65	149	0.604	1375
-24	-11.2	3.980	39002	21	69.8	1.842	5832	66	150.8	0.589	1335
-23	-9.4	3.940	37169	22	71.6	1.799	5621	67	152.6	0.574	1297
-22	-7.6	3.899	35433	23	73.4	1.757	5419	68	154.4	0.560	1260
-21	-5.8	3.858	33788	24	75.2	1.716	5225	69	156.2	0.546	1225
-20	-4	3.816	32230	25	77	1.675	5039	70	158	0.532	1190
-19	-2.2	3.773	30752	26	78.8	1.636	4861	71	159.8	0.519	1157
-18	-0.4	3.729	29350	27	80.6	1.596	4690	72	161.6	0.506	1125
-17	1.4	3.685	28021	28	82.4	1.558	4526	73	163.4	0.493	1093
-16	3.2	3.640	26760	29	84.2	1.520	4369	74	165.2	0.481	1063
-15	5	3.594	25562	30	86	1.483	4218	75	167	0.469	1034
-14	6.8	3.548	24425	31	87.8	1.447	4072	76	168.8	0.457	1006
-13	8.6	3.501	23345	32	89.6	1.412	3933	77	170.6	0.446	978
-12	10.4	3.453	22320	33	91.4	1.377	3799	78	172.4	0.435	952
-11	12.2	3.405	21345	34	93.2	1.343	3670	79	174.2	0.424	926
-10	14	3.356	20418	35	95	1.309	3547	80	176	0.414	902
-9	15.8	3.307	19537	36	96.8	1.277	3428	81	177.8	0.404	877
-8	17.6	3.258	18698	37	98.6	1.253	3344	82	179.6	0.394	854
-7	19.4	3.208	17901	38	100.4	1.213	3204	83	181.4	0.384	832
-6	21.2	3.158	17142	39	102.2	1.183	3098	84	183.2	0.375	810

# TROUBLESHOOTING

DATA2. Humidity Sensor table

- Voltage output table @23°..., 5Vdc --- HTG3515CH/HTG3535CH

RH(Temperature compensate) = RH (Relative Humidity) + (Temp(°C) °c 23°C) x 0.05

RH(%)	Output (mV)	A/D (10 bit)	A/D (12 bit)	RH(%)	Output (mV)	A/D (10 bit)	A/D (12 bit)	RH(%)	Output (mV)	A/D (10 bit)	A/D (12 bit)
0	909	186	744	46	2246	460	1839	92	3452	706	2827
1	943	193	772	47	2272	465	1861	93	3478	712	2848
2	977	200	800	48	2298	470	1882	94	3504	717	2870
3	1010	207	827	49	2324	475	1903	95	3530	722	2891
4	1043	213	854	50	2350	481	1925	96	3566	730	2920
5	1076	220	881	51	2376	486	1946	97	3595	735	2944
6	1109	227	908	52	2402	491	1967	98	3624	741	2968
7	1141	233	935	53	2428	497	1989	99	3653	747	2992
8	1173	240	961	54	2454	502	2010	100	3683	754	3016
9	1205	247	987	55	2480	507	2031				
10	1235	253	1011	56	2505	513	2052				
11	1266	259	1037	57	2530	518	2072				
12	1297	265	1062	58	2555	523	2093				
13	1328	272	1088	59	2580	528	2113				
14	1359	278	1113	60	2605	533	2133				
15	1390	284	1138	61	2630	538	2154				
16	1420	291	1163	62	2655	543	2174				
17	1450	297	1188	63	2680	548	2195				
18	1480	303	1212	64	2705	553	2215				
19	1510	309	1237	65	2730	559	2236				
20	1540	315	1261	66	2756	564	2257				
21	1569	321	1285	67	2782	569	2278				
22	1598	327	1309	68	2808	575	2300				
23	1627	333	1333	69	2834	580	2321				
24	1656	339	1356	70	2860	585	2342				
25	1685	345	1380	71	2886	590	2364				
26	1713	350	1403	72	2912	596	2385				
27	1741	356	1426	73	2938	601	2406				
28	1769	362	1449	74	2964	606	2428				
29	1797	368	1472	75	2990	612	2449				
30	1825	373	1495	76	3017	617	2471				
31	1852	379	1517	77	3044	623	2493				
32	1879	384	1539	78	3071	628	2515				
33	1906	390	1561	79	3098	634	2537				
34	1933	395	1583	80	3125	639	2559				
35	1960	401	1605	81	3152	645	2581				
36	1986	406	1627	82	3179	650	2604				
37	2012	412	1648	83	3206	656	2626				
38	2038	417	1669	84	3233	661	2648				
39	2064	422	1690	85	3260	667	2670				
40	2090	428	1712	86	3288	673	2693				
41	2116	433	1733	87	3316	678	2716				
42	2142	438	1754	88	3344	684	2739				
43	2168	444	1776	89	3372	690	2762				
44	2194	449	1797	90	3400	696	2785				
45	2220	454	1818	91	3426	701	2806				

# TROUBLESHOOTING

## 4-3) Case Output Terminal

(The Main PCB and the Case Output Terminals are connected with wire connectors.)

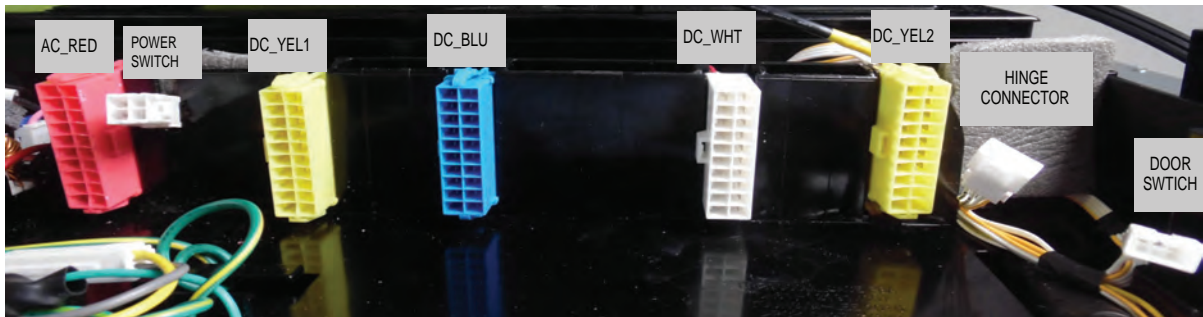

\* Test the terminals on the PCB Case to check for voltage of operation related errors concerning BUILT-IN PJT. The terminal composition is shown in the diagram. If an error is found while testing  
The above terminals and the housing connectors, check the inside of the PCB Case.  
=>The following descriptions are based on the PCB Case.



# TROUBLESHOOTING

## (PLATE FIXER HOUSING PIN MAPPING)

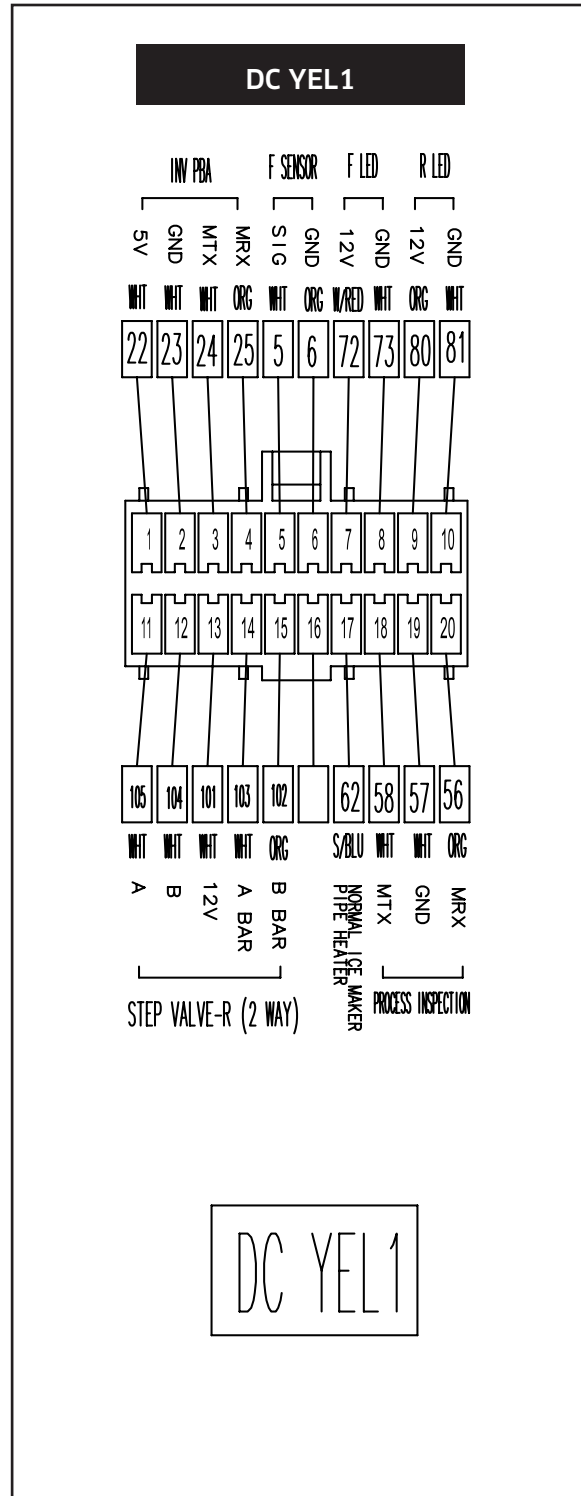
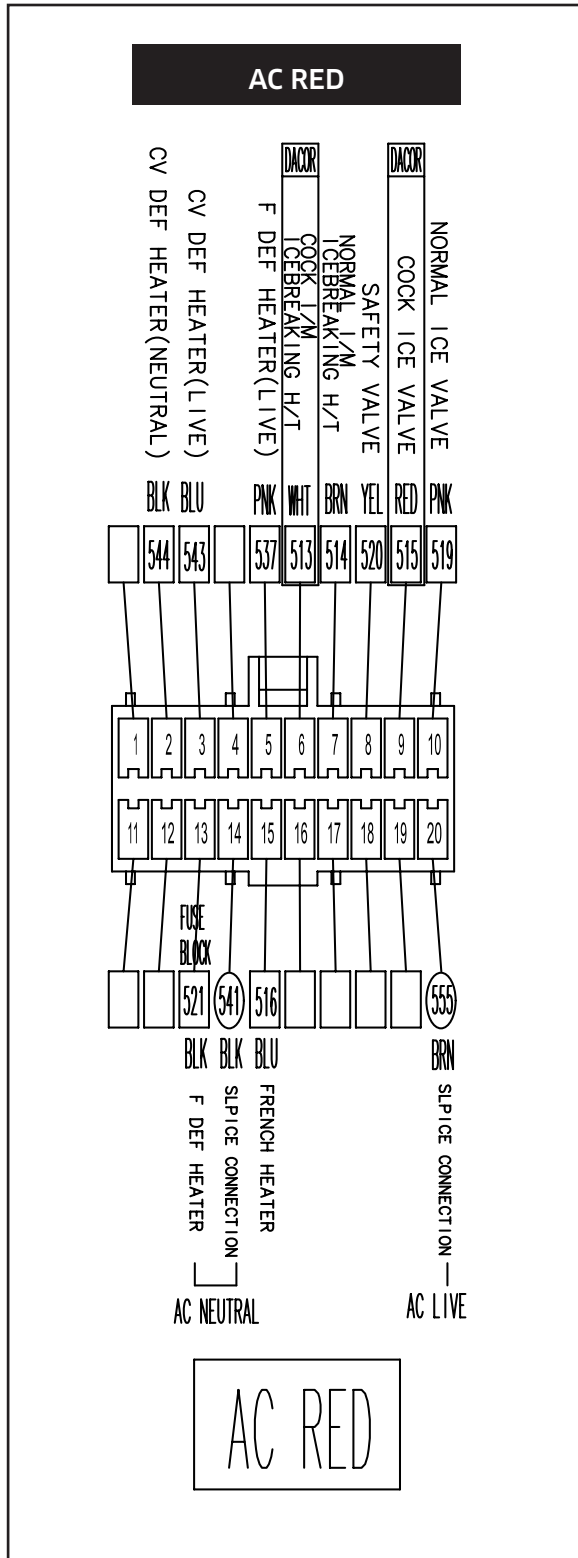

# TROUBLESHOOTING

## (PLATE FIXER HOUSING PIN MAPPING)

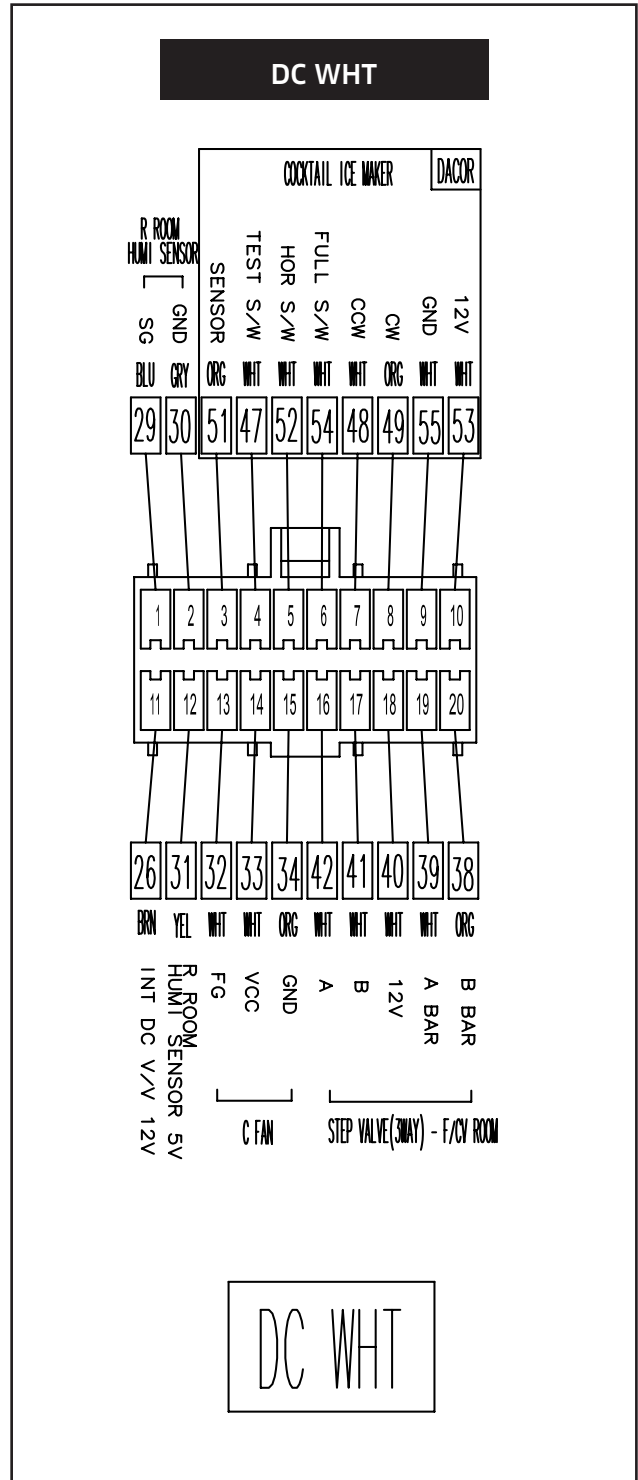
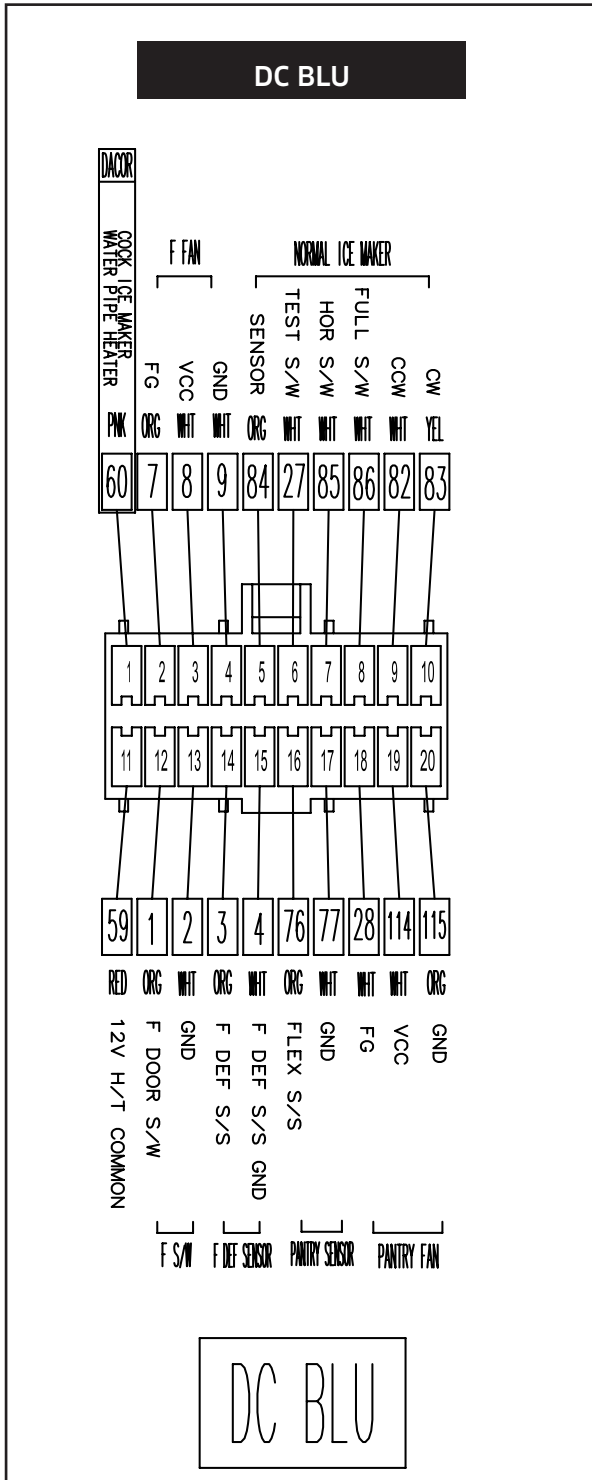



# TROUBLESHOOTING

(PLATE FIXER HOUSING PIN MAPPING)

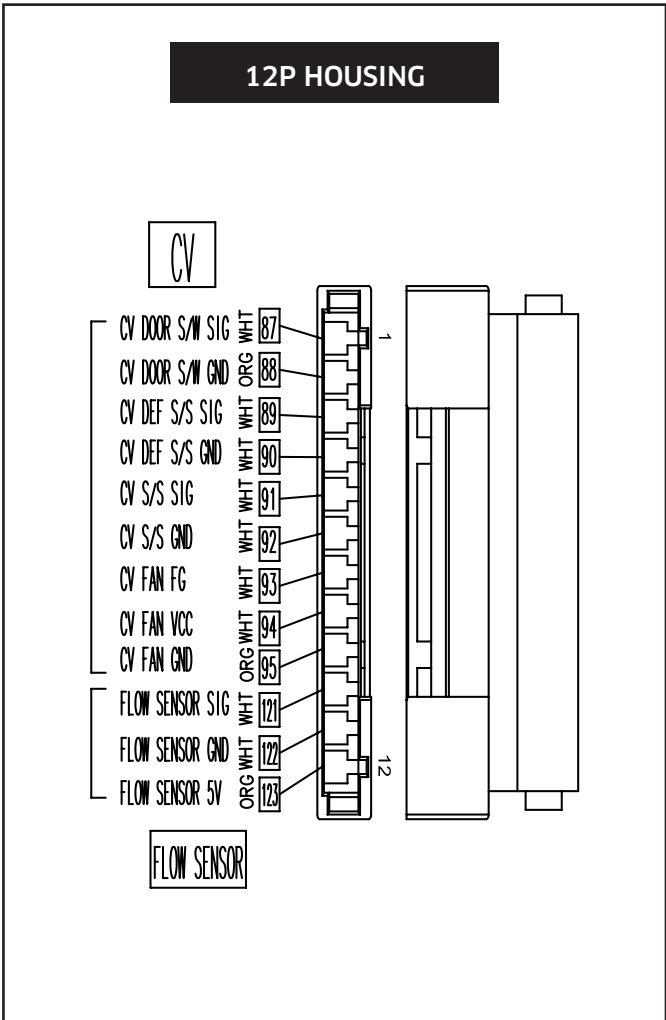
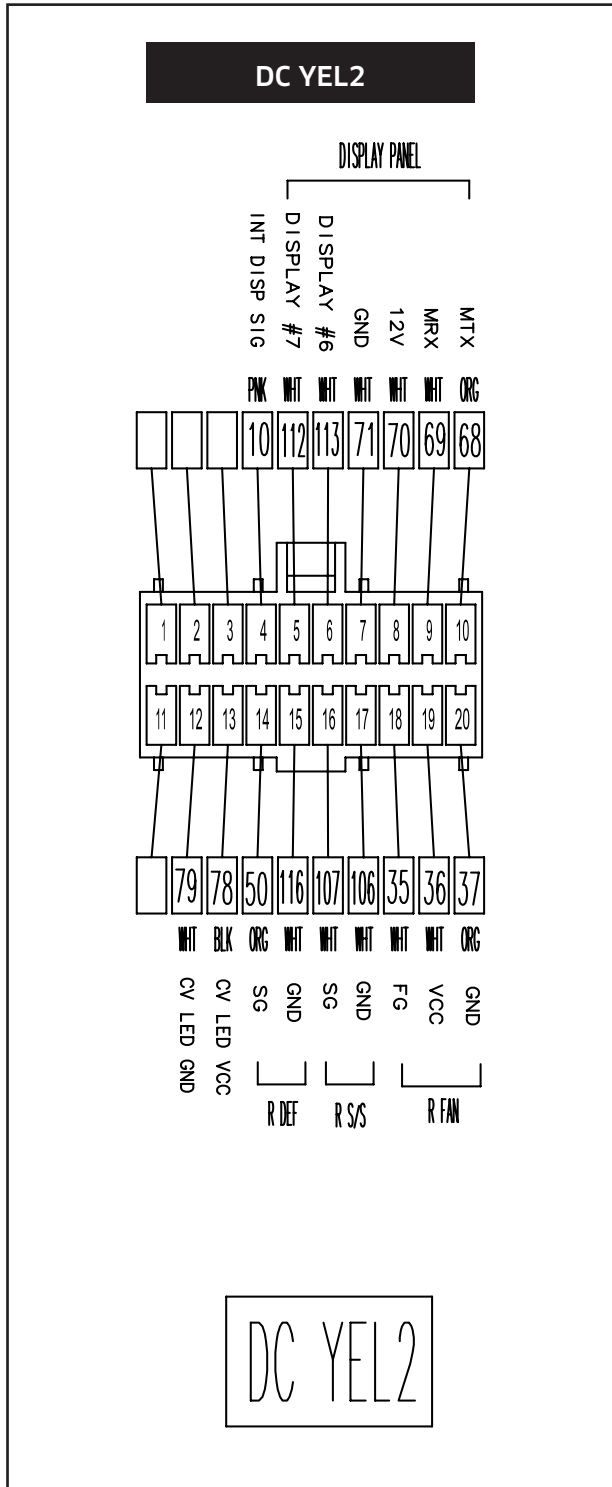

# TROUBLESHOOTING

(PLATE FIXER HOUSING PIN MAPPING)

## DOOR S/W & BUZZER

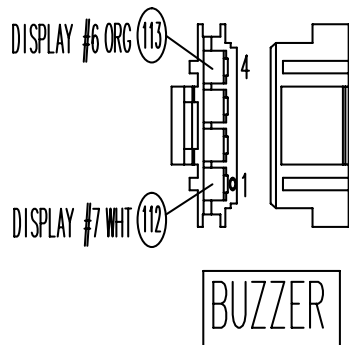
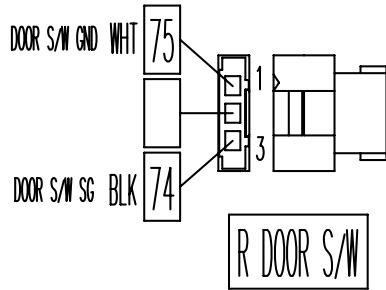

## EXT SENSOR

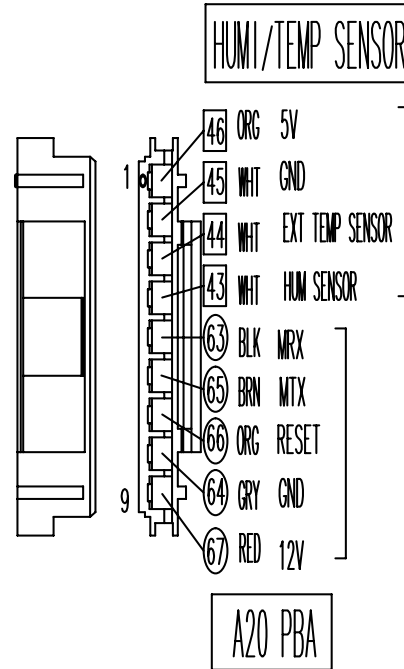

# TROUBLESHOOTING

(PLATE FIXER HOUSING PIN MAPPING)

## DC WHT

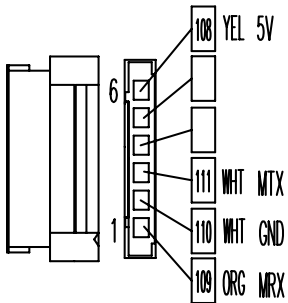

HASS (BLU)

## POWER SWITCH

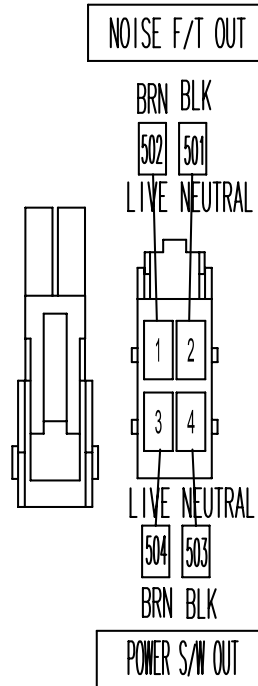

## F DEF HEATER FUSE BLOCK

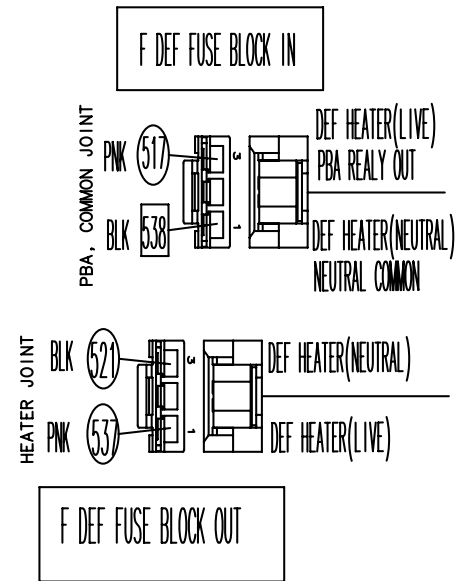

# TROUBLESHOOTING

## 4-4) How to Enter the Test Mode

### 1) When there is no Power (SMPS PCB)

**CAUTION** There are AC input voltage running on Power switch connector. So, be cautious when repairing the unit or measuring values.

SMPS PCB CHECK Using Multimeter

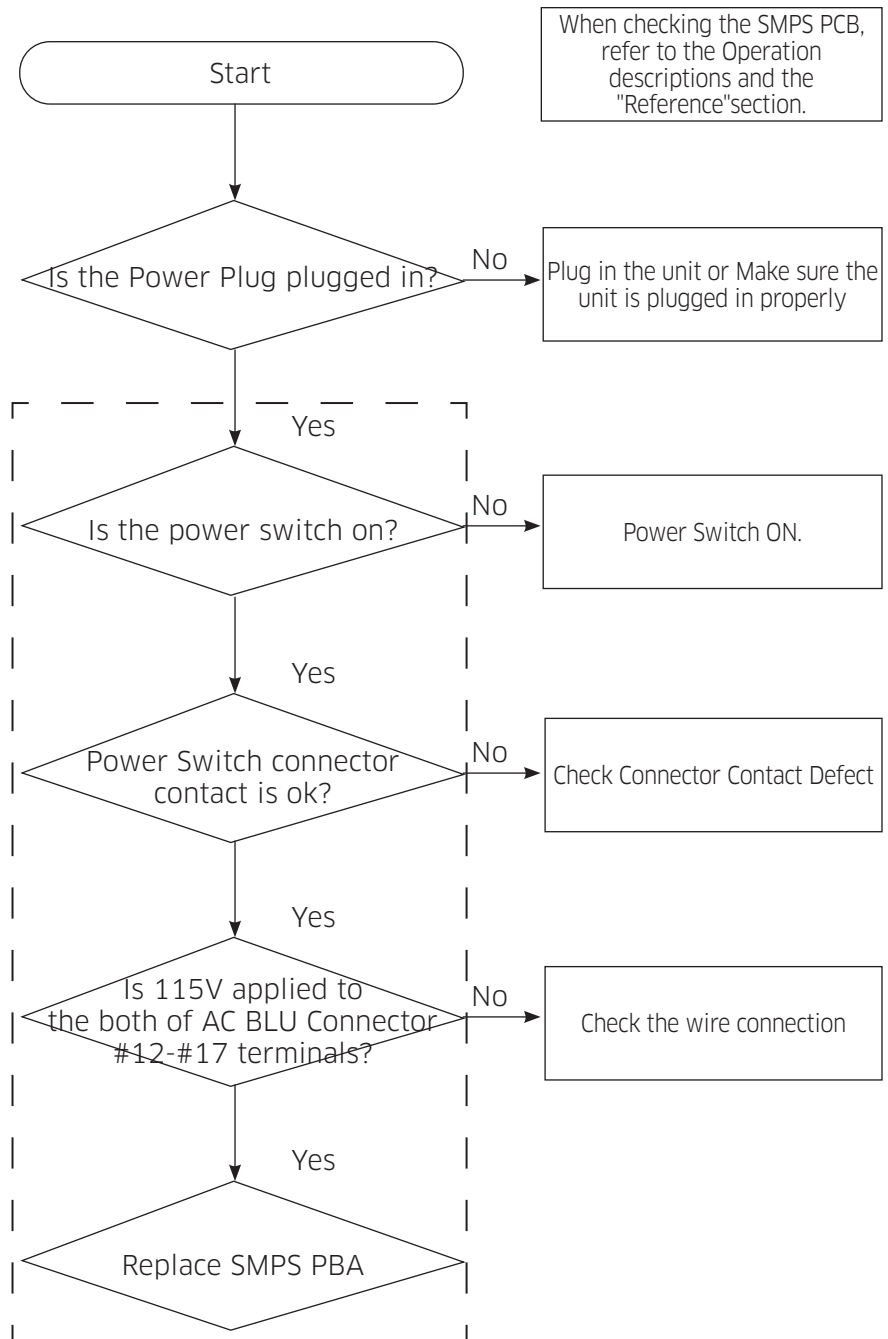
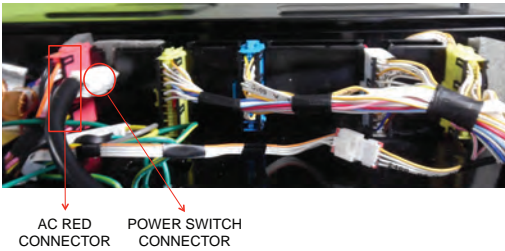

# TROUBLESHOOTING

## 2) When the compressor does not operate (Inverter Comp)

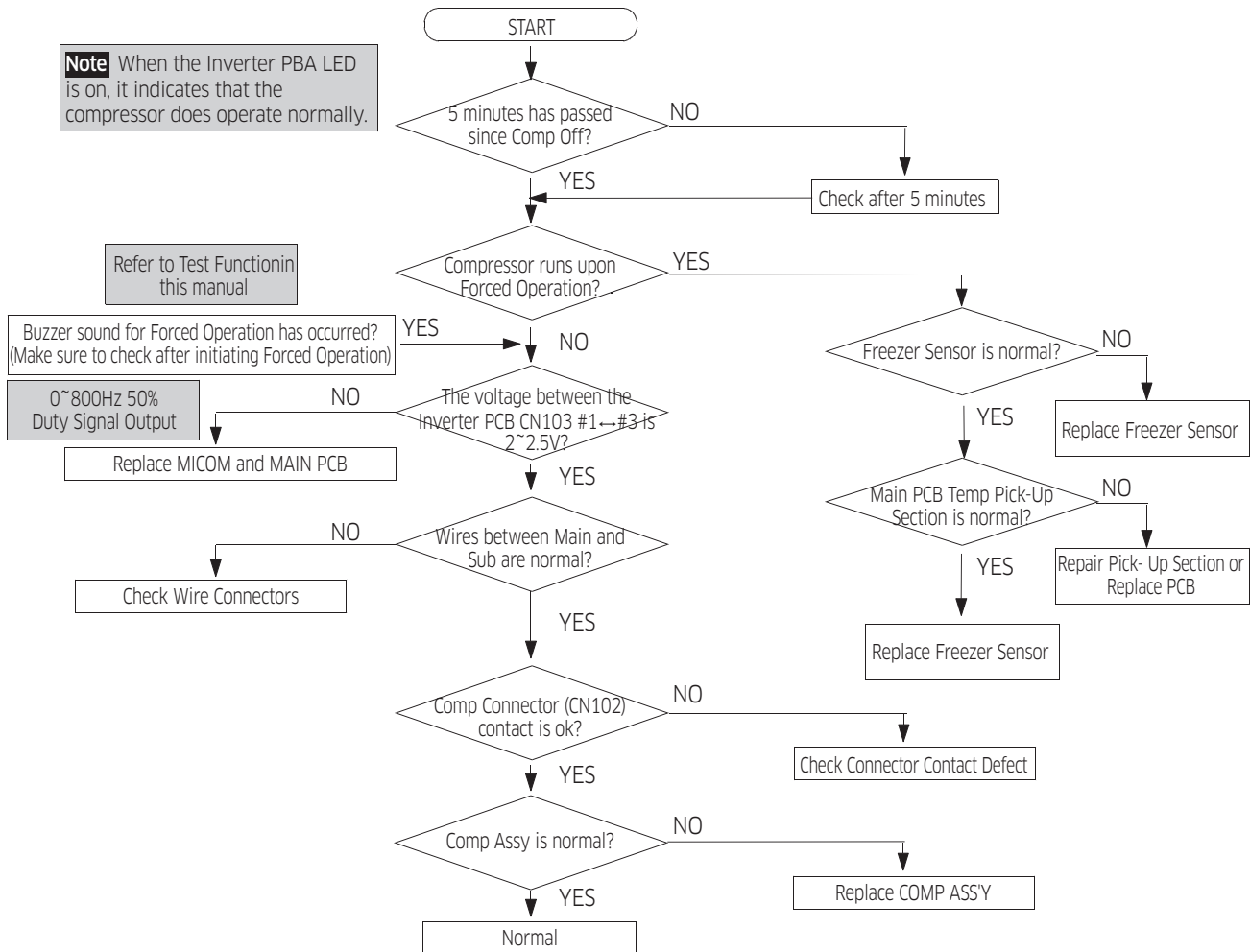







# TROUBLESHOOTING

## 3) Troubleshooting based on LED Blinking Frequency

When failure is detected by the Inverter PCB, the Compressor will immediately stop if the Compressor is running and there will be a 5 minute standby. During the 5 minute standby, RPM signals will be ignored.

That is, even though the Inverter PCB receives the RPM signals, the Compressor does not work.

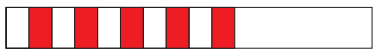
It blinks every second and there is 2 second off at the end of each cycle.

LED Blinking Frequency	Protecting Functions	Remarks
	Normal Operation	N/A
	Starting Failure	1. Check the COMP terminals short(U,V,W) 2. Check IPM Pins short of Inverter PBA 3. Check IPM operating Voltage(under DC 13.5V) 4. Other cases, check the COMP, cycle, etc.
	IPM Fault	1. Check COMP wire connections(U,V,W) 2. Check PCB Bottom side soldering state 3. Other cases, check the COMP, cycle, etc.
	Abnormal Current Detection	1. Check COMP wire connections(U,V,W) 2. Check PCB Bottom side soldering state 3. Other cases, check the COMP, cycle, etc.
	Motor Locked / Over RPM	1. Check PCB Bottom side soldering state. 2. Check Input voltage oscillation 3. Other cases, check the COMP, cycle, etc.
	Under Voltage	1. Check input voltage under AC 53V(Input Power AC110 ~ 127V) or AC 106V(Input Power AC220 ~ 240V) 2. Check PCB Bottom side soldering state.
	Over Voltage	1. Check input voltage over AC 155V(Input Power AC110 ~ 127V) or AC 310V(Input Power AC220 ~ 240V) 2. Check PCB Bottom side soldering state.

# TROUBLESHOOTING

## 4) When Defrost does not work

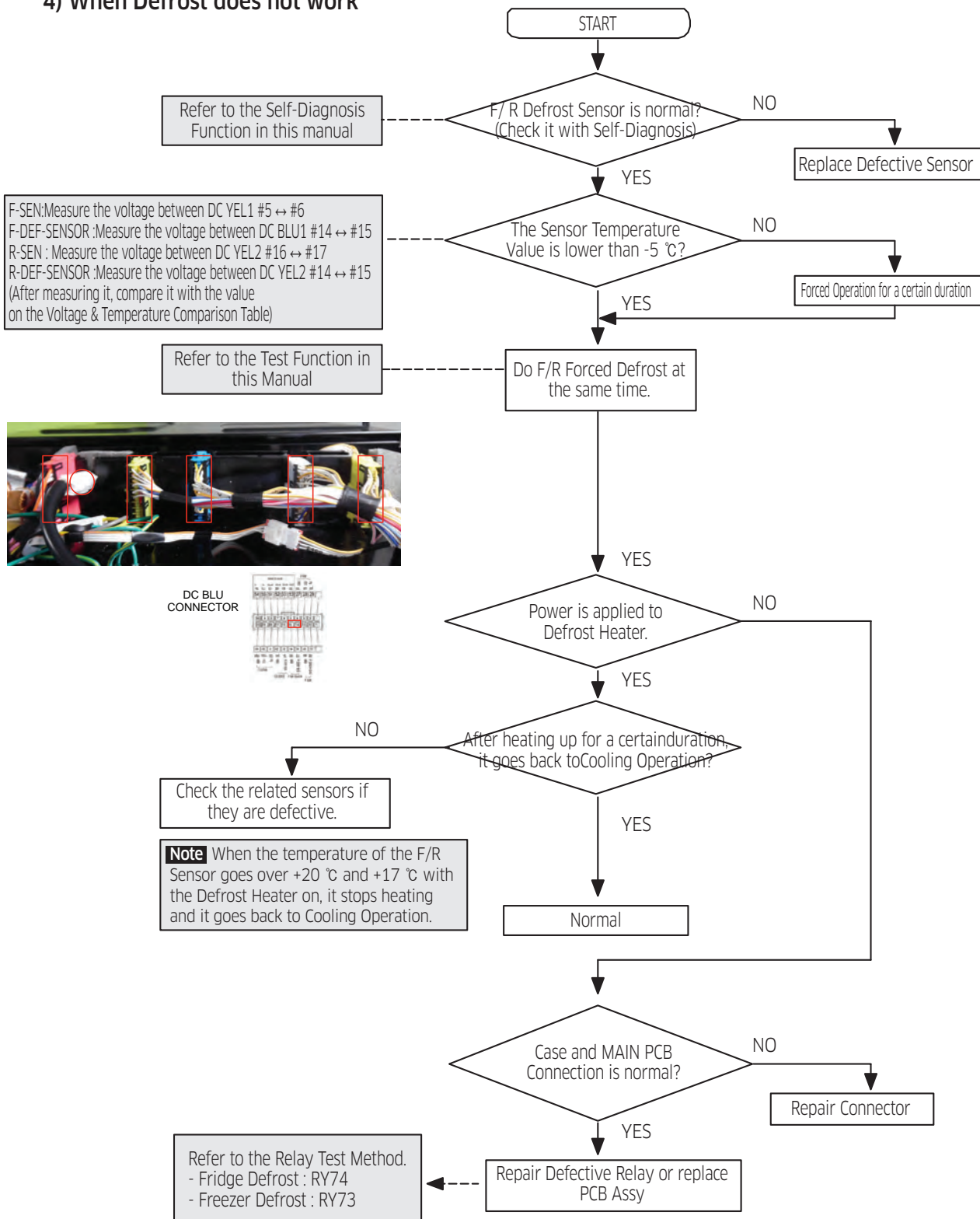

# TROUBLESHOOTING

## 5) When there is Self-Diagnosis Error (with Defective Sensor)

- The error of sensor will be displayed on the front of display. when the error of sensor is detected at initial power ON, the appliance will not operated and the error message will be displayed.
- The appliance will not stop operating when the error of sensor is detected during operation of the appliance. But normal freezing might be not operated if the appliance is operated by the emergency operation mode. You would better to check the appliance according to the self-diagnosis of the manual.

- ① When R-Room Sensor error occurs (check the other sensors in the same procedure)  
 - Measure with PCB Case as a base

Check the wires connected to the Case Output Connector

- Fridge (Based on Case Wires)
- Room Sensor : DC YEL2 #16 ↔ #17
- Defrost Sensor : DC YEL2 #14 ↔ #15
- Freezer (Based on Case Wires)
- Room Sensor : DC YEL1 #5 ↔ #6
- Defrost Sensor : DC BLU1 #14 ↔ #15
- Ambient Sensor (Based on Case Wires)  
: HINGE CONNECTOR #2 ↔ #3
- Ambient-Humidity Sensor (Based on Case Wires)  
: HINGE CONNECTOR #2 ↔ #4
- Pantry Sensor : DC BLU1 #16 ↔ #17
- R-Humidity Sensor : DC WHT #1 ↔ #2

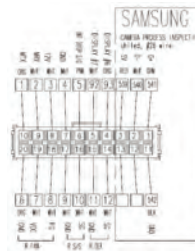
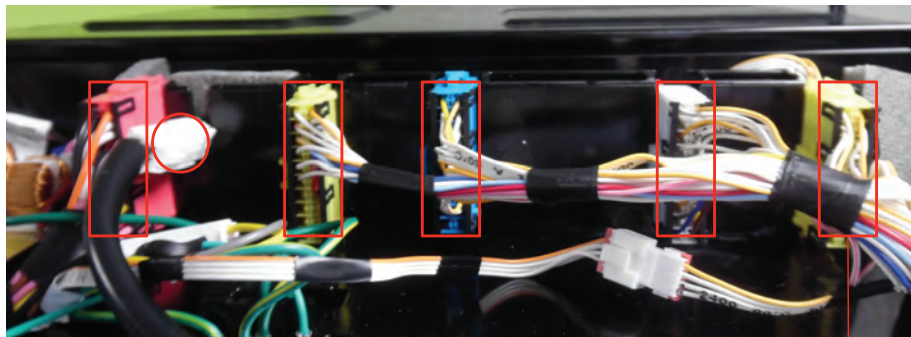
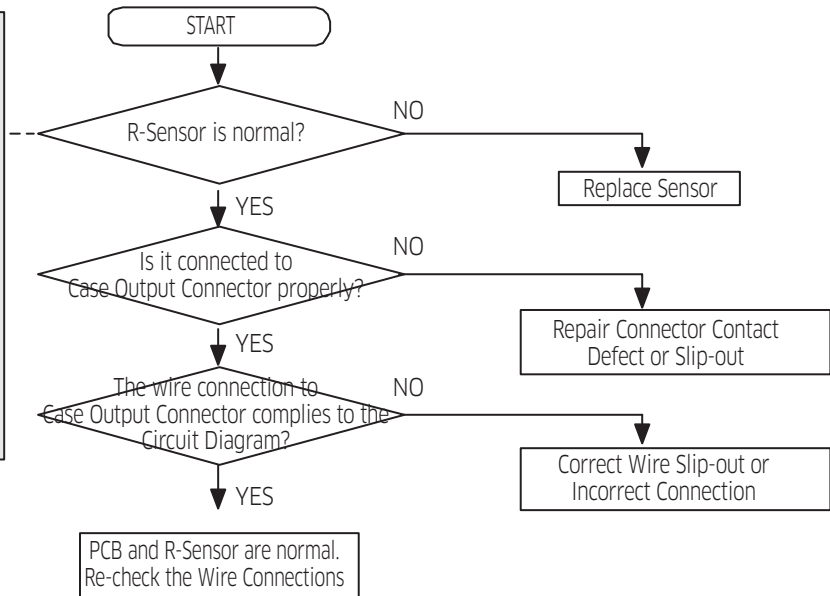

DC YEL 2 CONNECTOR



# TROUBLESHOOTING

## 6) When the alarm sound will not turn off.

### ① When Door Open "Sound" keeps alarming

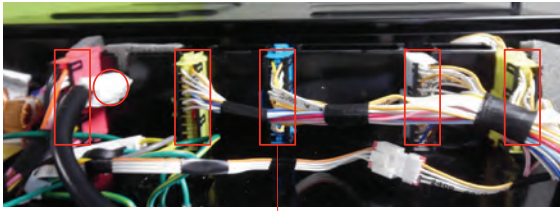

Freezer Door S/W : DC BLUE CONNECTOR

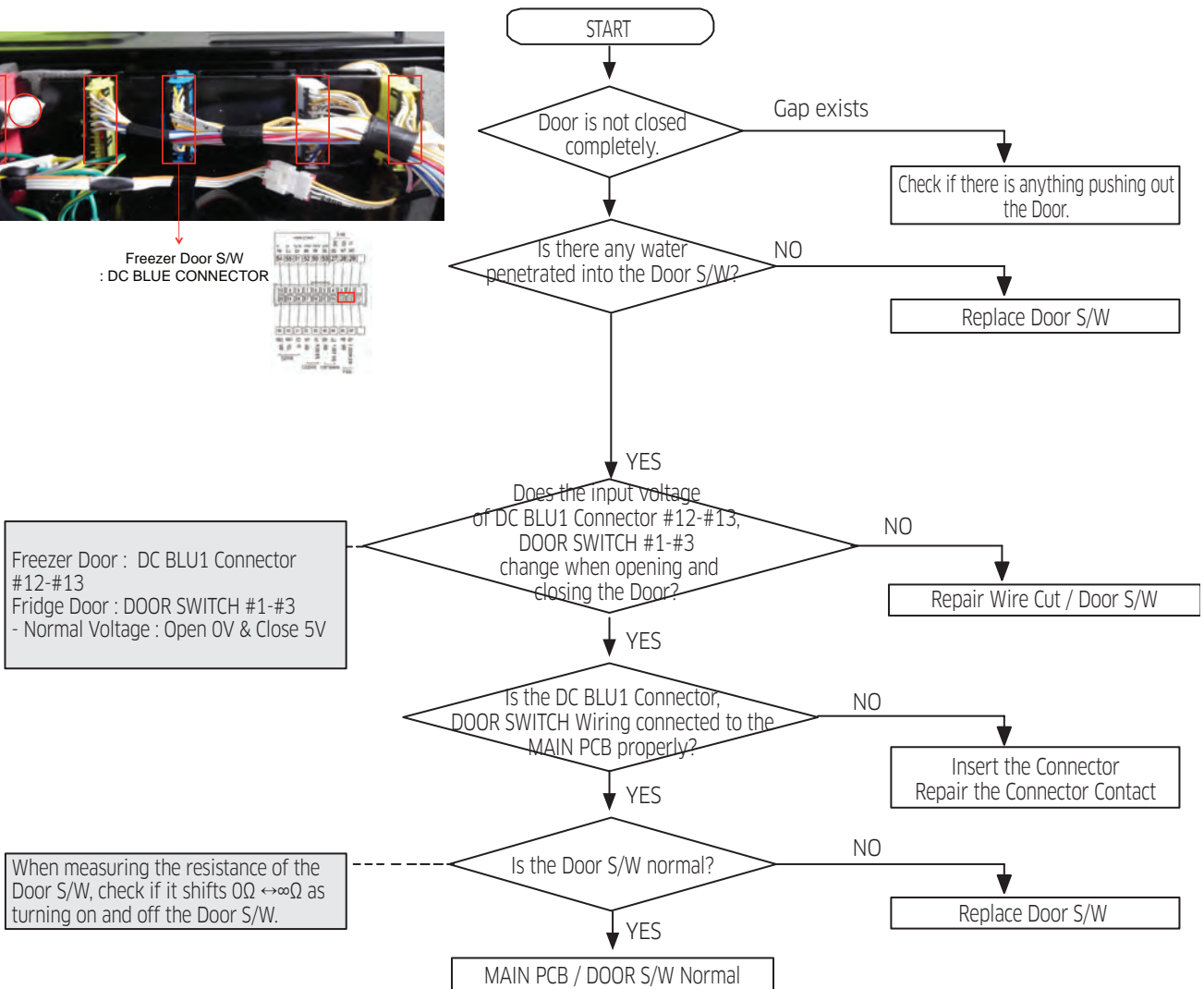

### ② When alarm sound "Beep" continues

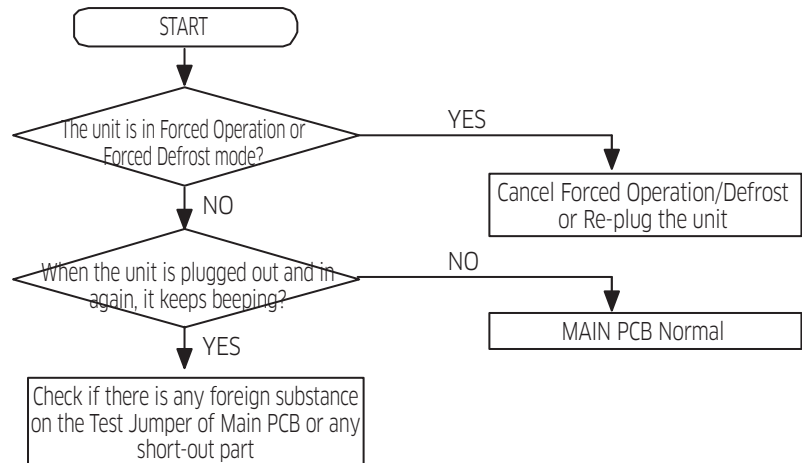

# TROUBLESHOOTING

## 7) When the Display is defective or there is Communication Error

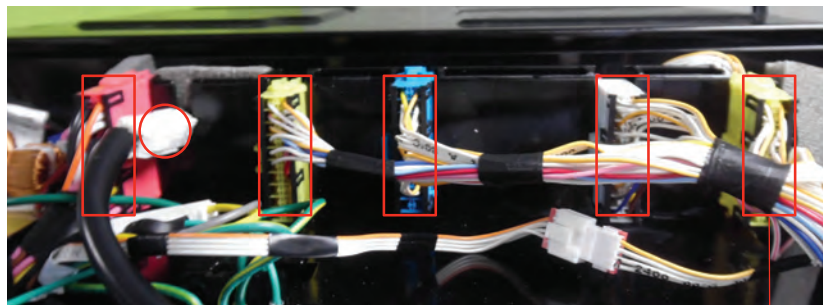
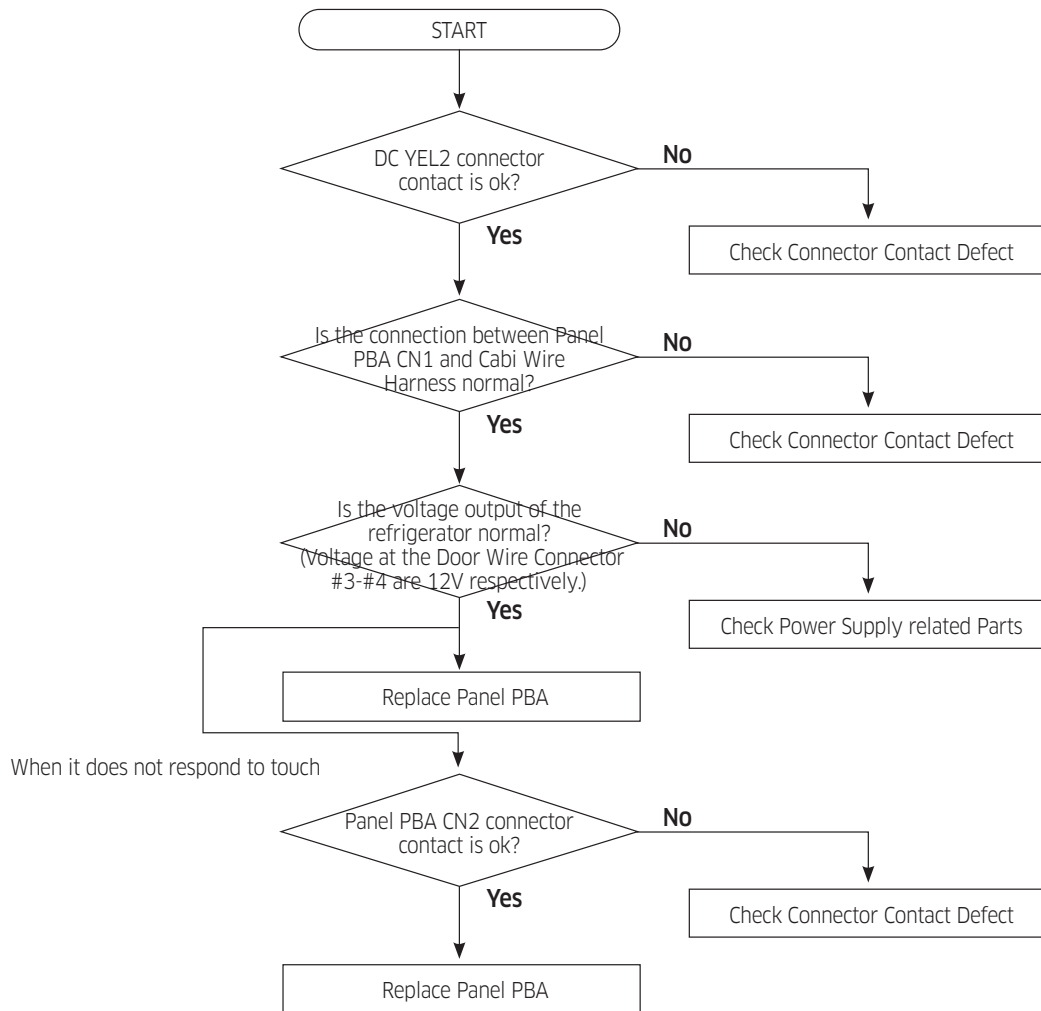

DC YEL 2 CONNECTOR

# TROUBLESHOOTING

## 8) When Fan does not operate

- This refrigerator uses the BLDC Fan Motor. The BLDC Motor operates with DC 7~12V.
- Under Comp On conditions, the F-Fan operates generally. But, the F-Fan Motor may not work due to various conditions (such as the operating condition of Cool Select Pantry, etc) and when the ambient temperature is high or when you open and close the Door once, it operates after one minute delay. So, don't get misled by it. It is normal.
- Also, when the Fridge Door is open, the Freezer Fan Motor stops together with the Fridge Fan Motor (for the purpose of performance improvement).

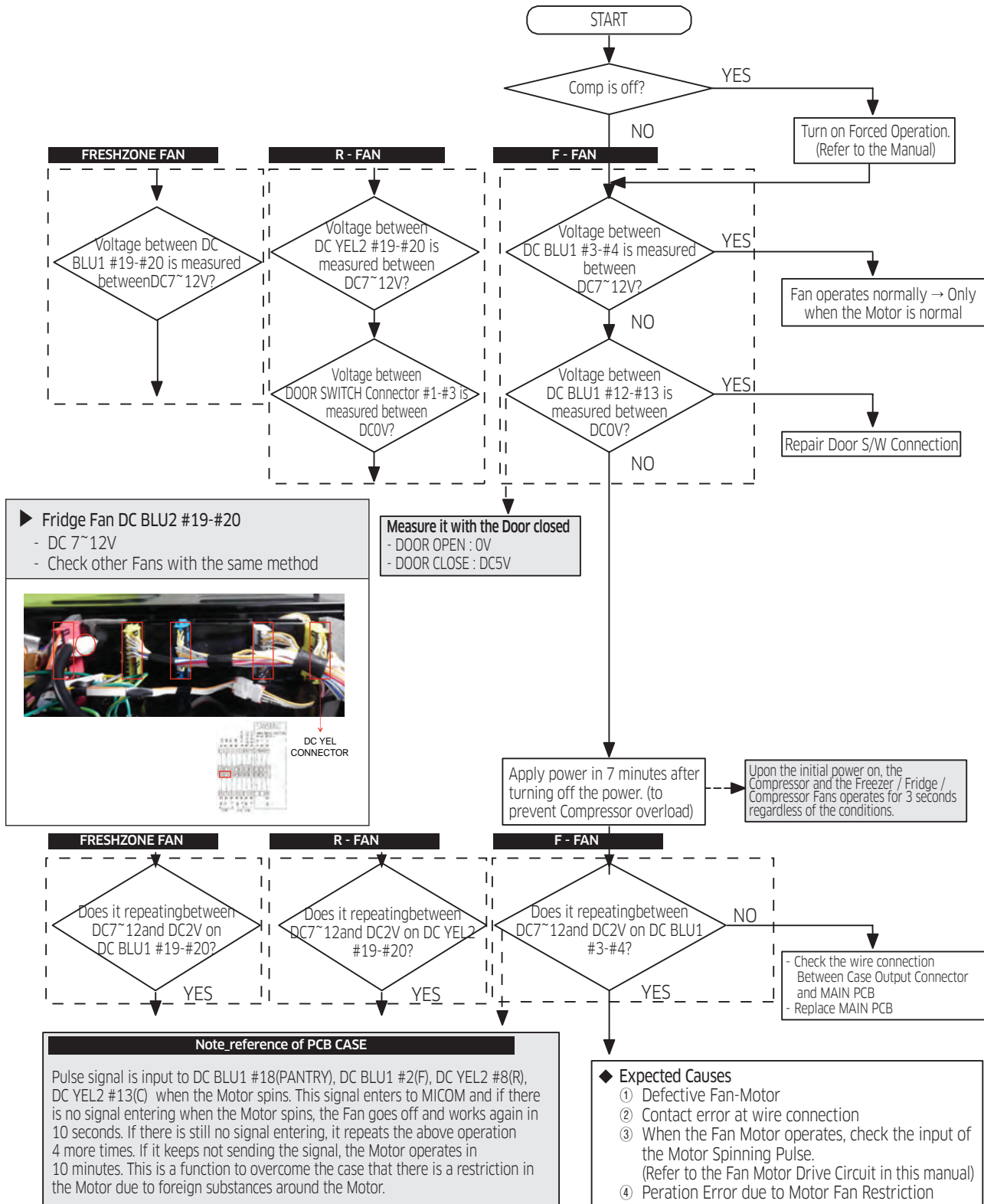

# TROUBLESHOOTING

## 9) When the Freezer / Fridge Lamp does not light up

### CAUTION

1. When replacing the Freezer Lamp, be sure to turn off the power to prevent electric shock.
2. LED lamps are used in the both of the Fridge and the Freezer compartments of this model.

Remove the Door S/W. And, when measuring its resistance at its both terminals while opening and closing the Door, the value should change between  $0\Omega$  and  $\infty\Omega$ .  
 1)  $0\Omega$ : Door S/W is short.  
 2)  $\infty\Omega$ : Door S/W is open.

\* Measure point  
 1. Freezer : DC BLU1 Connector #12-#13  
 2. Fridge : DOOR SWITCH Connector #1-#3

\* Measure point  
 1. Freezer : DC YEL1 #7-#8  
 2. Fridge : DC YEL1 #9-#10

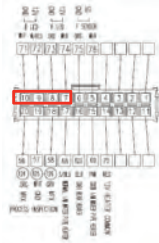
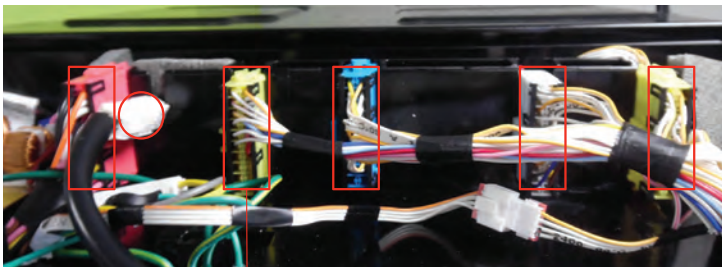
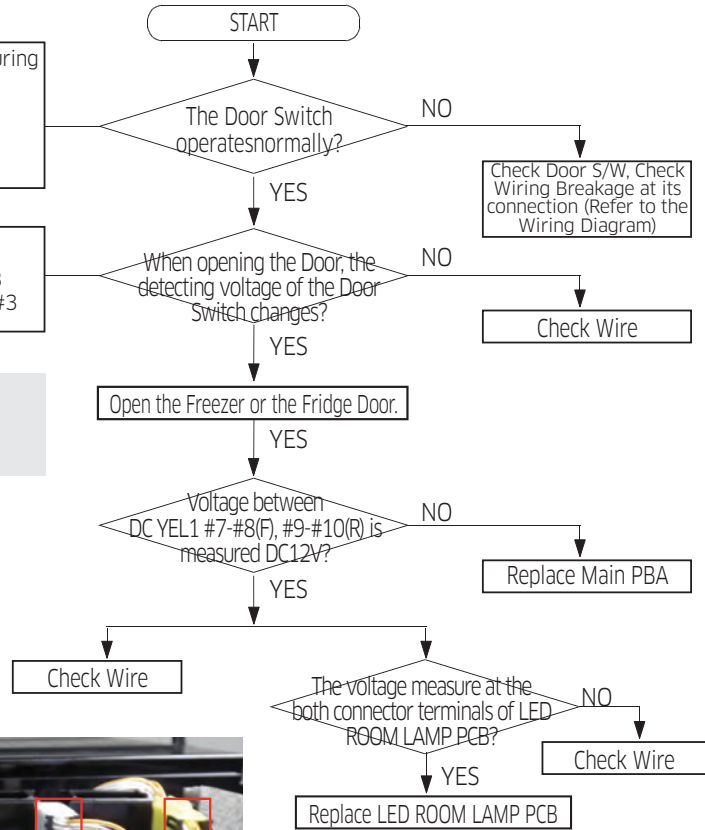

DC YEL 1

\* Voltage Values by Door Status

Location Case Output Connector	Freezer	Fridge
	DC BLU1 Connector #12-#13	DOOR SWITCH
OPEN	0V	0V
CLOSE	5V	5V

# TROUBLESHOOTING

## 10) When there is problem in the sound function

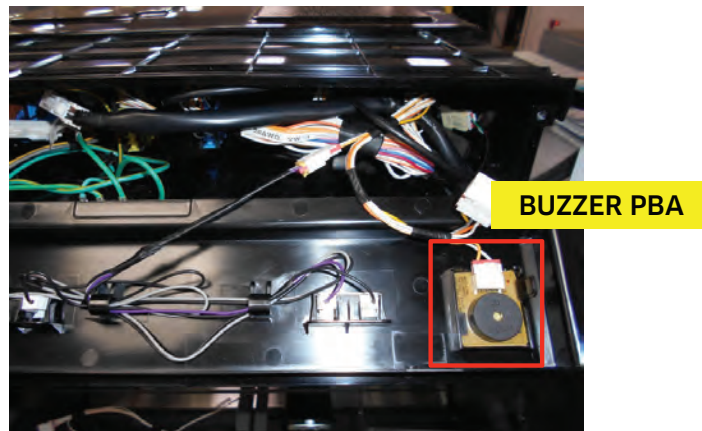
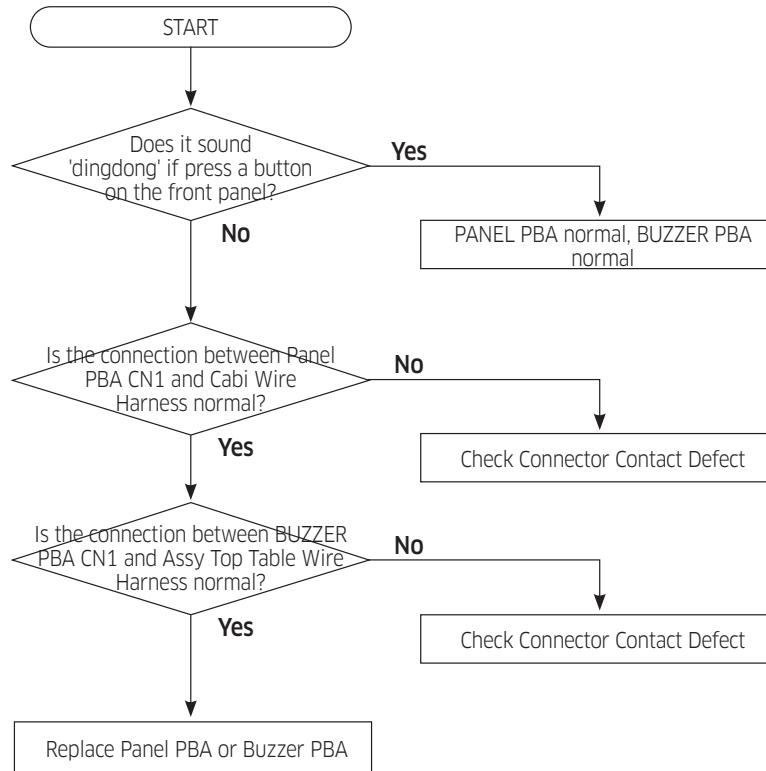

# TROUBLESHOOTING

## 12) When the Water Valve does not work

### Pre-checking

1. Water is directly supplied to the Water Valve. So, make sure to cut off the water before doing repairs.
2. There is electricity flowing in the wire. So, take extra care not to get electric shock.

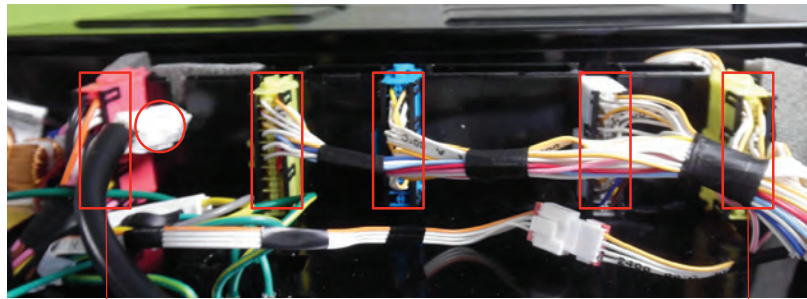
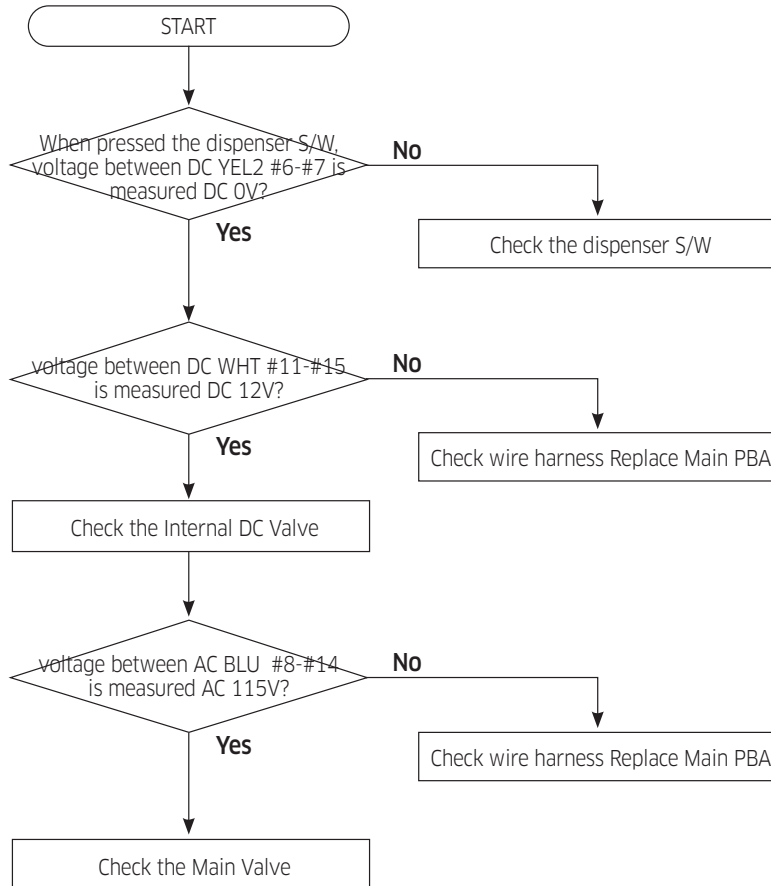

AC RED CONNECTOR



DC YEL CONNECTOR



# TROUBLESHOOTING

## 13) When ICE MAKER does not operate

1. Water will be automatically supplied to the Ice Maker depending on temperature & time conditions, and ice will be produced to dispense.
2. Power is applied to one end of the wires. So, make sure to refer to its Exploded View whenever doing the disassembly.
3. The operation of the Ice Maker shall be done after pressing the Ice Maker Test Button.  
(Fridge Ice Maker) It is not possible to check when the power is off.
4. Since both of the PCB and the Ice Maker are located at the front and the back each other, make sure to have two people check them.
5. It may cause burn when the Ice Maker Heater heats up. So, please take an extra caution.
6. The Ice Maker has a counter-clockwise rotation function. So, its counter-clockwise rotation is normal.

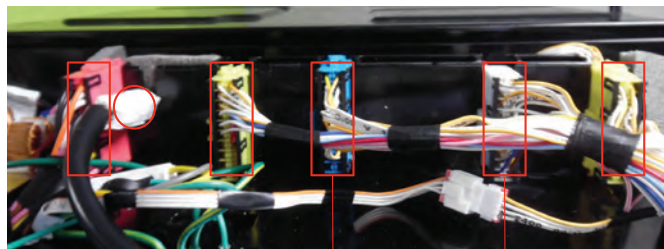
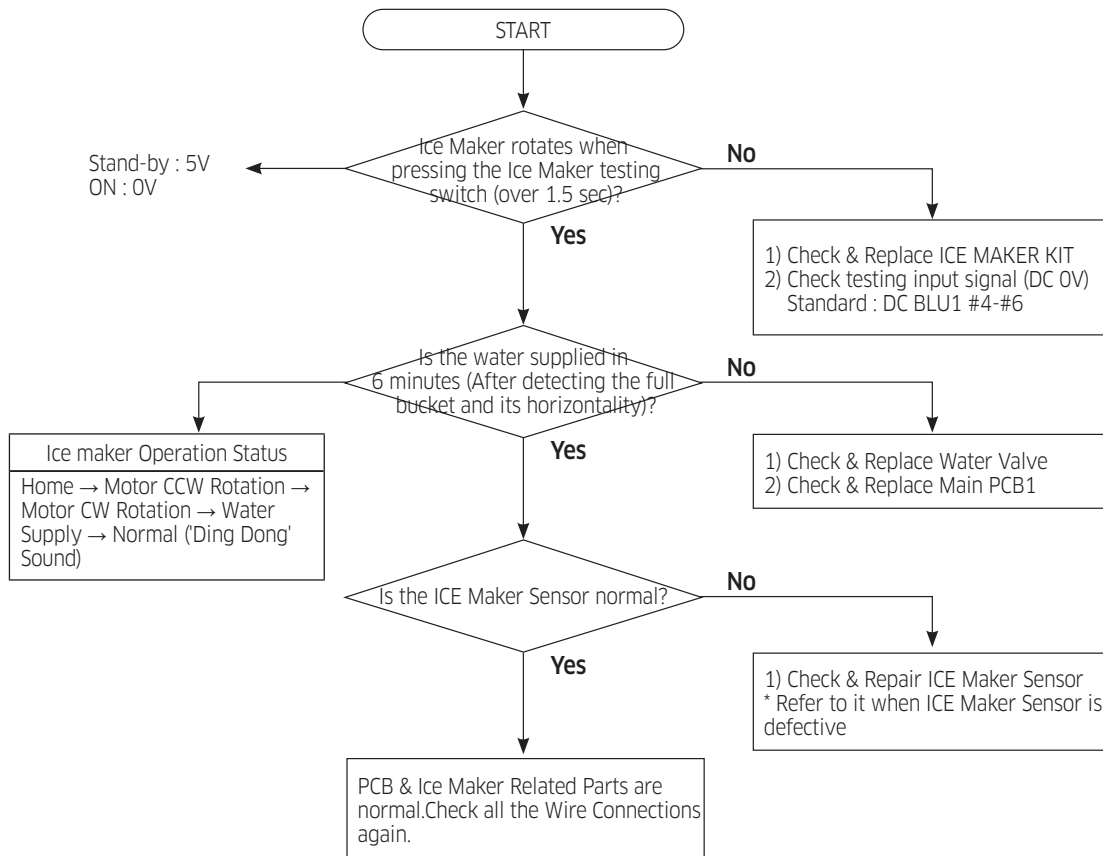

DC BLU CONNECTOR



DC WHT CONNECTOR

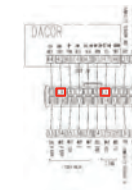



# TROUBLESHOOTING

## 14) When Wi-Fi does not operate properly

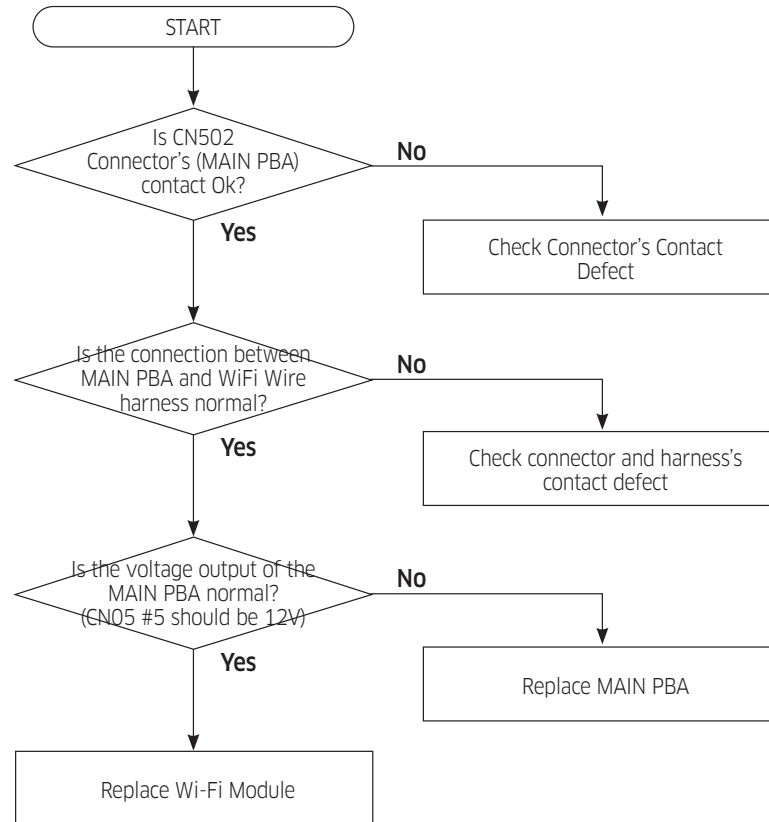



## 5. PCB DIAGRAM

### 5-1) PBA Layout with part position

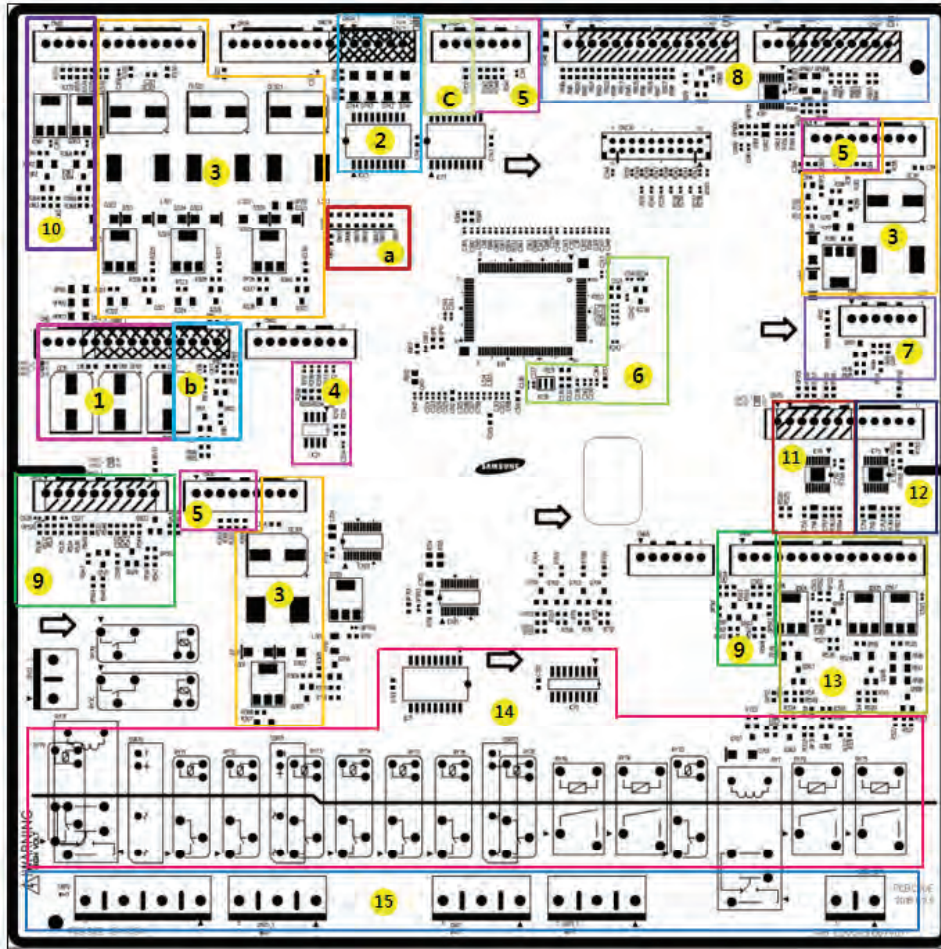

1. DC12V, 5V, GND supplied from SMPS PCB (Not Used)
2. Circuit for controlling Step-Valve (3-Way Valve) \* Option
3. FAN MOTOR control part : To supply the power from 7V ~ 12V according to the motor types. (F,R,C,ICE)
4. EEPROM : Save and record every kinds of data.
5. Transmit inputted signals from every sensor into MICOM after eliminate the noise.
6. Micom : control the refrigerator Ceramic resonator : generate the basic frequency of Micom operation. Reset IC : make Micom reset if input voltage of Micom is detected less than the specified voltage
7. PLC input/output- PLC (Power Line communication) \* Option (PLC module is not inserted unless specified occasion)
8. Operate ICE-MAKER, supply power to MOTOR, and sense the variation of switch.
9. Main Micom ↔ Panel Micom serial communication circuit - Dispenser option input part (Water & Cover Ice route switch)
10. Auto Fill control part
11. Control Mid drawer Room damper & Damper heater
12. Water Tank Heater Controls (also controls other options)
13. LED LAMP Control Circuit (F,R room Lamp)
14. Relay parts that controls AC load and receives Micom operating signal through Sink IC.
15. Connector with AC loads. Diode option setting area. Inverter COMP controlling signal c. Flow Sensor controlling signal



# PCB DIAGRAM

## 5-3) Connector Layout with part position (Main Board)

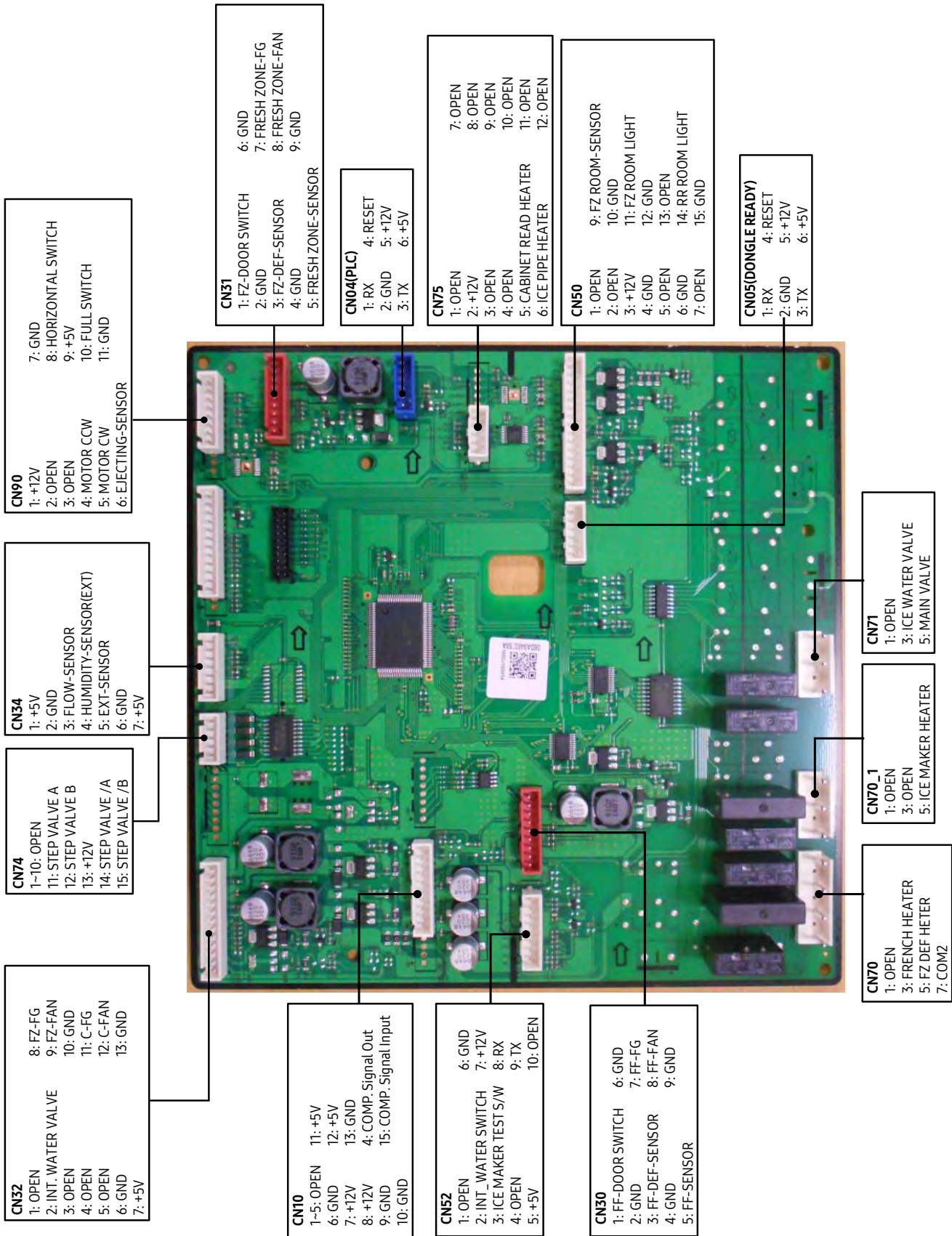



# PCB DIAGRAM

## 5-4) Connector Layout with part position (Inverter PBA, SMPS PBA)

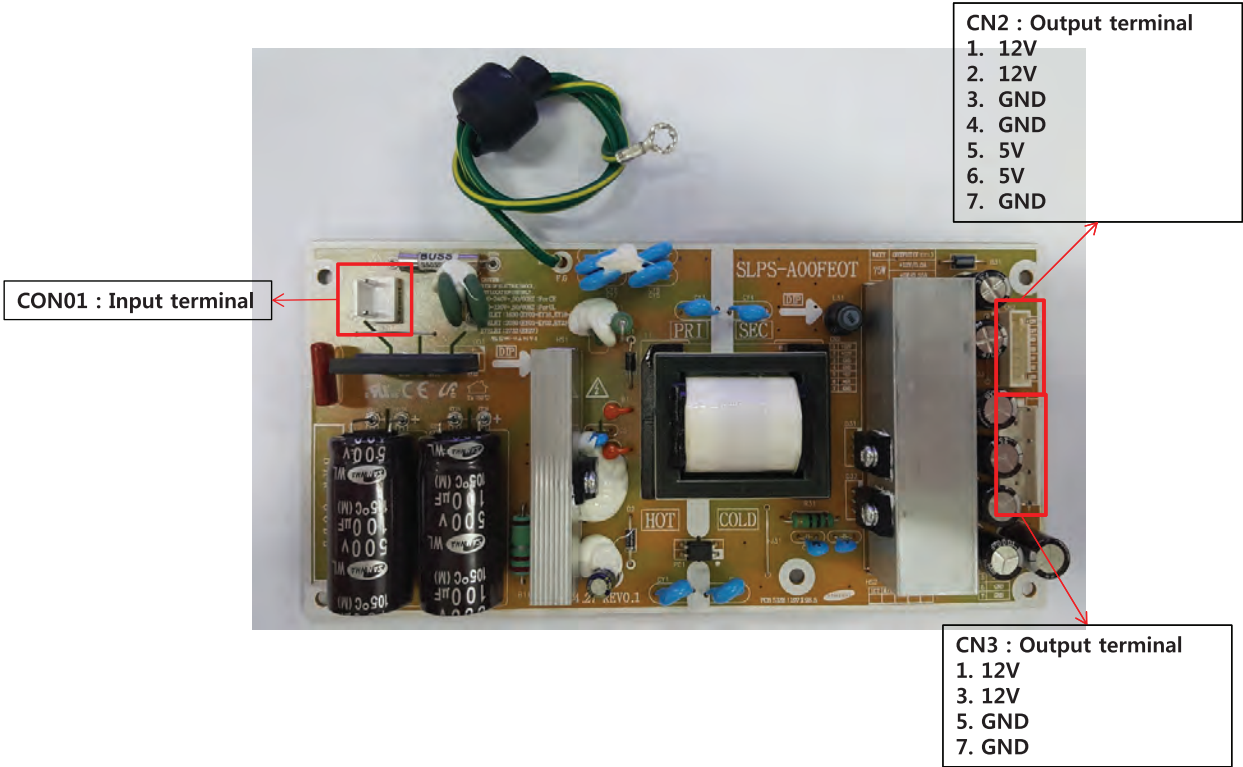
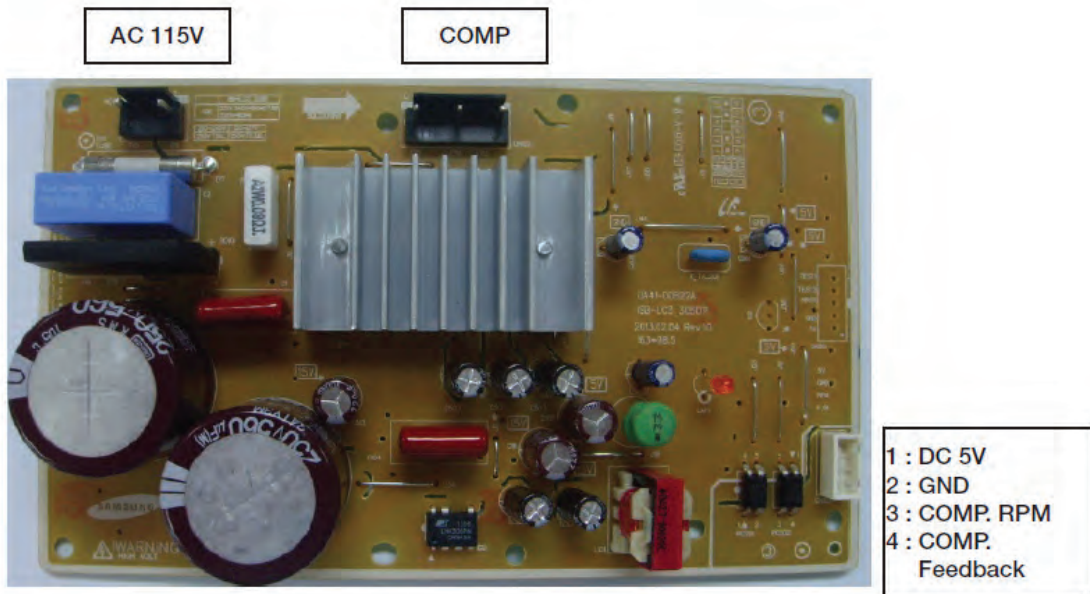

# PCB DIAGRAM

## 5-5) Wi-Fi Module(4709-002829)'s Pin Assignment



CON1 : MAIN PBA ↔ Wi-Fi Module  
#1 TX / #2 RX / #3 RST / #4 GND / #5 12V

# 6. WIRING DIAGRAM

## 6-1) Whole block diagram

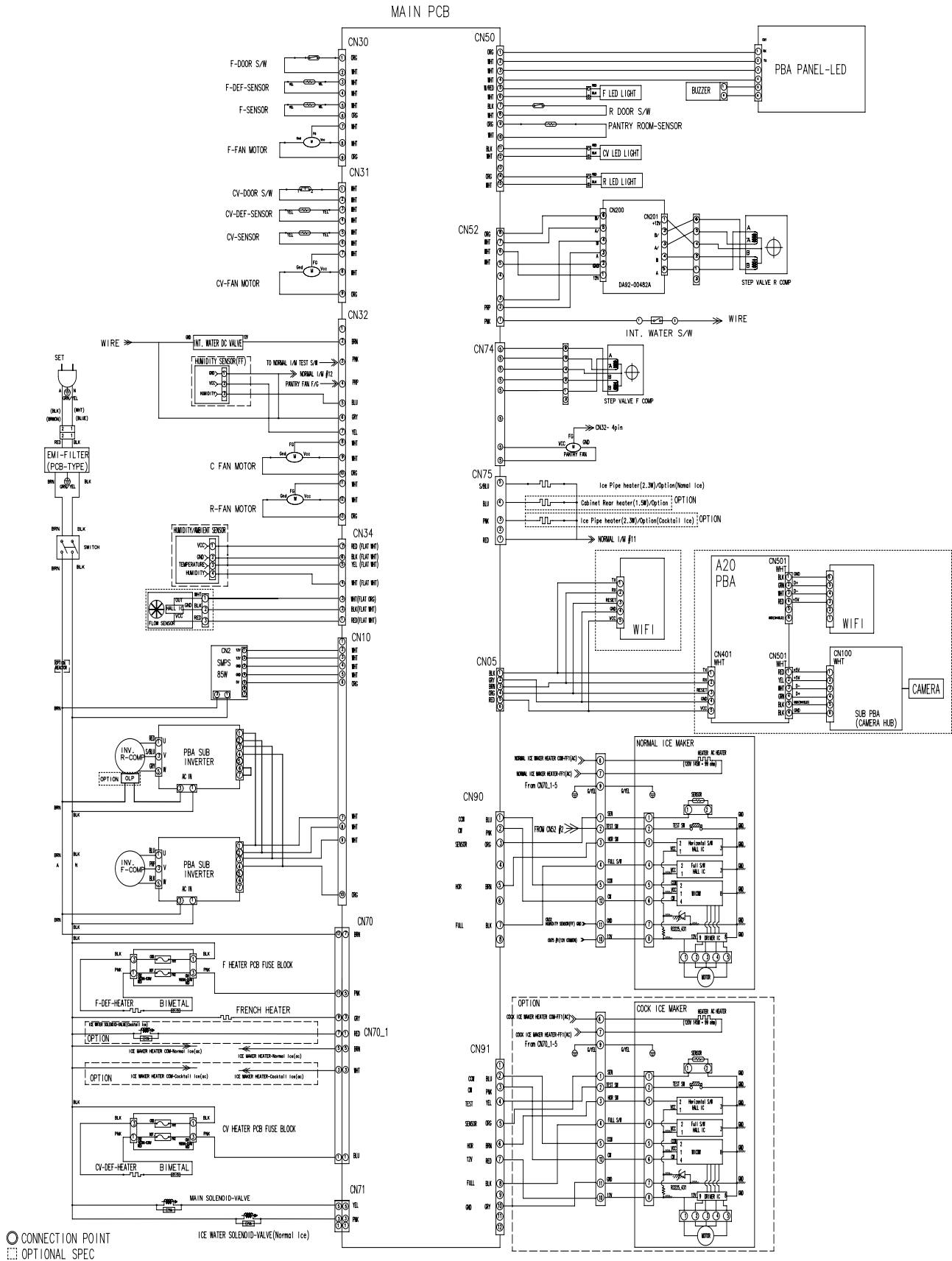

# WIRING DIAGRAM

## 6-2) Wiring Diagram

BUILT-IN 42 INCH T

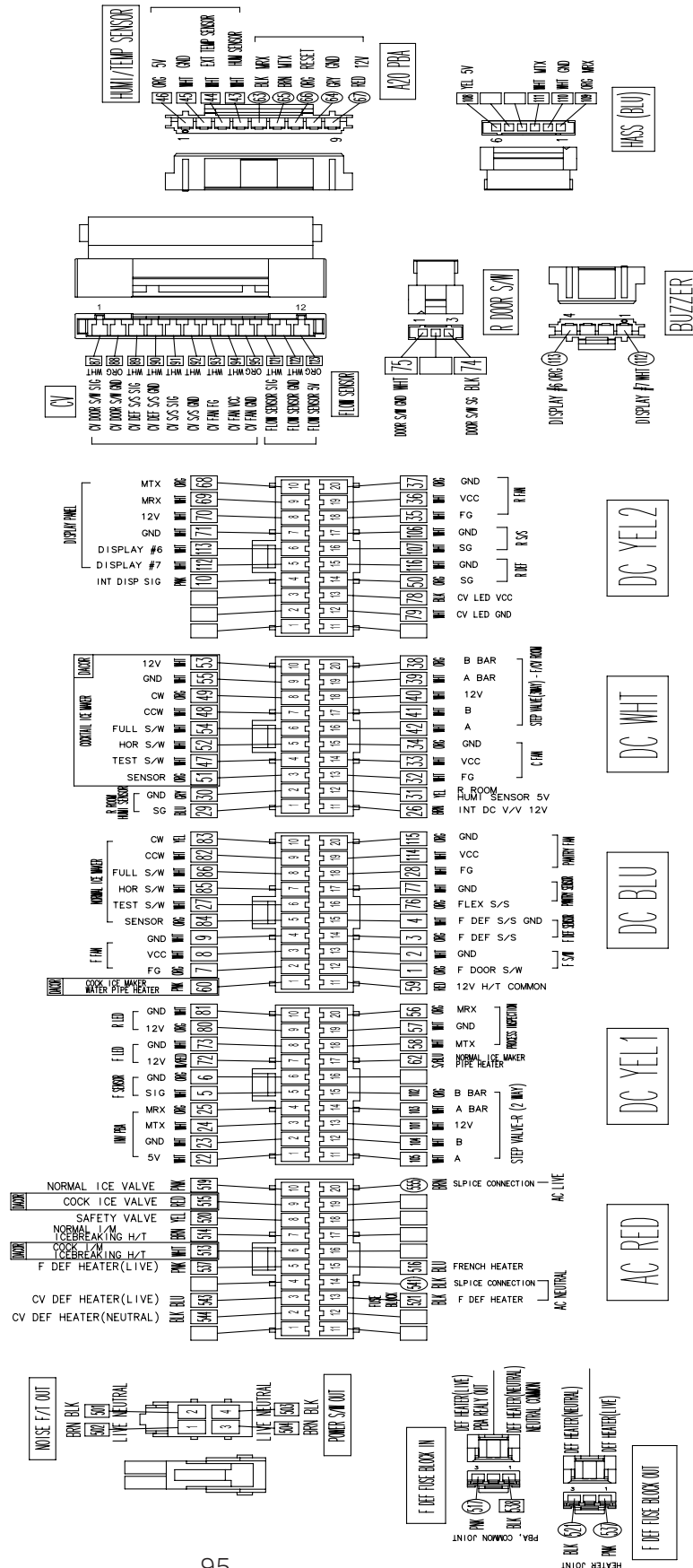





## 8. REFERENCE INFORMATION

### 8-1) Trouble Shooting

PROBLEM	SOLUTION
<b>The Refrigerator does not work at all or it does not chill sufficiently.</b>	<ul style="list-style-type: none"> <li>• Check that the power plug is properly connected.</li> </ul>
	<ul style="list-style-type: none"> <li>• Check the set temperature on the digital display is warmer than freezer or fridge inner temperature.</li> </ul>
	<ul style="list-style-type: none"> <li>• Try setting it to a lower temperature.</li> </ul>
	<ul style="list-style-type: none"> <li>• Is the Refrigerator in direct sunlight or located near a heat source?</li> </ul>
<b>The food in the Refrigerator is frozen.</b>	<ul style="list-style-type: none"> <li>• Check the set temperature on the digital display is too low.</li> </ul>
	<ul style="list-style-type: none"> <li>• Try setting it to a warmer temperature.</li> </ul>
	<ul style="list-style-type: none"> <li>• Is the temperature in the room too low? Try setting it to a warmer temperature.</li> </ul>
	<ul style="list-style-type: none"> <li>• Did you store the food which is juicy in the coldest part of the Refrigerator? Try moving those items on the other shelves in fridge instead of keeping them in the Cool Select Pantry™.</li> </ul>
<b>You hear unusual noise or sounds.</b>	<ul style="list-style-type: none"> <li>• Check that the Refrigerator is level and stable.</li> </ul>
	<ul style="list-style-type: none"> <li>• Was anything dropped behind or under the Refrigerator?</li> </ul>
	<ul style="list-style-type: none"> <li>• A “ticking” sound is heard from inside the Refrigerator. It is normal and occurs because various accessories are contracting or expanding according to the temperature of the Refrigerator interior.</li> </ul>
<b>The front corners and vertical hinged section of the appliance are hot and condensation is occurring.</b>	<ul style="list-style-type: none"> <li>• Some heat is normal as anti-condensators are installed in the vertical hinged section of the Refrigerator to prevent condensation.</li> </ul>
	<ul style="list-style-type: none"> <li>• Is the Refrigerator door ajar? Condensation can occur when you leave the door open for a long time.</li> </ul>
	<ul style="list-style-type: none"> <li>• If a sound that hit something is heard from inside the refrigerator, it is normal and occurs because ice dropping make a sound by periods.</li> </ul>

## REFERENCE INFORMATION

PROBLEM	SOLUTION
<b>Ice Maker is not producing ice.</b>	<ul style="list-style-type: none"> <li>• Did you wait for 12 hours after installation of the water supply line before making ice?</li> </ul>
	<ul style="list-style-type: none"> <li>• Is the water line connected and the shut-off valve opened?</li> </ul>
	<ul style="list-style-type: none"> <li>• Is the Freezer temperature too warm? Try setting the Freezer temperature lower.</li> </ul>
<b>You can hear water bubbling in the Refrigerator.</b>	<ul style="list-style-type: none"> <li>• This is normal. The bubbling comes from the Refrigerator coolant liquid circulating through the Refrigerator.</li> </ul>
<b>There is a bad smell in the Refrigerator.</b>	<ul style="list-style-type: none"> <li>• Check for spoiled food.</li> </ul>
	<ul style="list-style-type: none"> <li>• Foods with strong odors(for example, fish) should be tightly covered.</li> </ul>
	<ul style="list-style-type: none"> <li>• Clean out your Freezer periodically and throw away any spoiled or suspicious food.</li> </ul>
<b>Frost forms on the walls of the Freezer</b>	<ul style="list-style-type: none"> <li>• Is the air vent blocked? Remove any obstructions so air can circulate freely.</li> </ul>
	<ul style="list-style-type: none"> <li>• Allow sufficient space between the foods stored for efficient air circulation.</li> </ul>
	<ul style="list-style-type: none"> <li>• Is the Freezer drawer closed properly?</li> </ul>
<b>Water dispenser is not functioning.</b>	<ul style="list-style-type: none"> <li>• Is the water line connected and the shut-off valve opened?</li> </ul>
	<ul style="list-style-type: none"> <li>• Has the water supply line tubing been crushed or kinked? Make sure the tubing is free and clear of any obstruction.</li> </ul>
	<ul style="list-style-type: none"> <li>• Is the water tank frozen because the Refrigerator temperature is too low? Try selecting a warmer setting on the Digital display.</li> </ul>

# REFERENCE INFORMATION

## 8-2) Q&A

Descriptions of symptoms	Check Points	Corrective Measures
<p>▶ <b>Noise (resonance) problems keep on even though the noise generating BLDC motors for both of the compartments are replaced several times. What does generate the resonance and how can it be settled down?</b></p>	<p>When the BLDC fan motor rotates in low RPM, The friction with air is quite high and it generates “grinding” noises.</p>	<p>If you replace the ambient thermistor with a 2.7K resistance (detecting 109.4 °F), the BLDC fan motor rotates in high RPM, which reduces friction with air resulting in reduction of the “grinding” resonance.</p>
<p>▶ <b>What causes the “knocking” noises? How to solve it?</b></p>	<p>It makes “knocking” or “branch breaking” noises when the liner and the shelves hit each other due to the fluctuation of the inside air pressure upon door open/close. Also, these noises occur when the liners and the shelves hit each other as the liners expand and contract due to the temperature change in both of the compartments.</p>	<p>Check the clearance between the selves and the liners.</p> <p>① Freezer Shelves: Remove the trim shelves already attached and replace them with those supplied for service.</p> <p>② Fridge Shelves: Because noise-preventing trim selves are not attached, it needs attaching.</p>
<p>▶ <b>What is the solution if the same problem occurs even though the counter action in the service bulletin has been implemented already for the “knocking” noises?</b></p>	<p>Check if the selves wobble. If they do, have shelves sit firmly on their places.</p>	
<p>▶ <b>What causes the liquid passing noises from the back of the refrigerator?</b></p>	<p>Refrigerant goes into the evaporator via the capillary tube in which the refrigerant expands as it circulates the cooling cycle. At this time, the refrigerant is in its liquid state and it starts evaporating as it reaches at the inlet of the evaporator with a bigger diameter, which causes the refrigerant noises. And, it gets worse when the refrigerant does not flow freely.</p>	

## REFERENCE INFORMATION

Descriptions of symptoms	Check Points	Corrective Measures
▶ What is the solution for the compressor noises?	For new refrigerators	
	Check if the refrigerator is leveled.	Check if the refrigerator wobbles by shaking with hands.
	Check if there is enough clearance at the back of the refrigerator for the ventilation of the machine compartment.	If there is not enough clearance or it is blocked by things such as newspaper, there could be resonance noises.
	Required clearance around the product.	More than 2 inches from the back, 12 inches from the top and 4 inches from its sides.
▶ What is the solution for the compressor noises?	For old refrigerators	
	Dust could get built-up in the machine compartment. Then, its ventilation would get restricted which makes the refrigerator overheated resulting in the increase of the noise level.	Explain it to customers and let them clean dust or any other foreign substances in the machine compartment.
	As the vibration proof rubbers get hardened, noises generate during the comp operation. (The noise level is quite high.) → Replace the vibration proof rubbers.	The compressor is dislocated due to impact during its transportation such as moving-in. → Check if it's dislocated when it is more noisy after moving-in.
▶ During the comp start-up, iron friction noises occur. What causes them?	The reciprocation piston could get worn out or inner components could get dislocated.	
▶ What can be checked when the unit sends out noises?	<ol style="list-style-type: none"> <li>1. Check its symptoms and patterns.</li> <li>2. Check if the unit is installed on a firm and leveled floor.</li> <li>3. Check if the unit is installed close to the customer's living area.</li> <li>4. Check if the panel on the machine compartment hits on the rear wall and the unit has enough clearance with the rear wall.</li> <li>5. Check if the refrigerant pipes are shaped as normal.</li> </ol>	

## REFERENCE INFORMATION

Descriptions of symptoms	Check Points	Corrective Measures
<p>▶ <b>Why is the fridge compartment not cool? (Not a defect)</b></p>	<p>Advise customers to adjust its temperature level to one or two step higher. For example, when the ambient temperature is low such as in winter (especially, when you use it in the morning with the door not being opened or closed during the night), the compartment temperature could get increased by 33.8~35.6 °F. So, advise customers to shift its temperature level and explain to them that it does not affect its power consumption that much when its temperature setting is adjusted to one or two step lower.</p>	
<p>▶ <b>Why is the food melt even though the display of the freezer compartment shows -4 °F?</b></p>	<p>Check the compartment temperature with a thermometer.</p>	<p>If it is considered to be low cooling, When the BLDC motor fan does not rotate because its restriction is not picked up. When the evaporator is frozen-up (defrost it) Temp detection error according to the characteristic change of the thermistor (set the compartment temperature or replace the thermoistor)</p>
<p>▶ <b>What is the reason that vegetables get frozen even though the fridge compartment is set to MIN?</b></p>	<p>Replace the fridge thermistor because it could be faulty. 1st: Check if the thermistor works after referring to the self-diagnosis checklist on the MAIN-PCB cover. If the over-cooling keeps on even though there is no problem with the above, replace it.</p>	
<p>▶ <b>What can be done when frozen food gets melt in the freezer compartment or it does not cool down?</b></p>	<p>Defrost it by using hot water and check the defrost system for any fault. And then, eliminate the root causes so as to prevent it from reoccurring.</p>	
<p>▶ <b>Why doesn't the compressor operate upon power supply?</b></p>	<p>Upon the initial power on, the compressor starts operating after a five minute delay to protect the compressor. So, please wait until it starts operating.</p>	
<p>▶ <b>Why does it send out "Ding Dong" or alarm sounds with the doors closed?</b></p>	<p>Check if the food sticks out preventing the doors from closing properly. If it send out the above sounds with the door closed well, the door switch may not have been pressed down completely. So, make sure for the door switches to be pressed completely. Still, if it does not stop going off, check the wiring connections because the door switch signals may not be inputted into the PCB. And, when the door switch is faulty or it is not pressed down completely, the fan does not rotate and it causes low-cooling advancing to a defrost problem.</p>	
	<p>Note : When it comes to automatic models, the fan motor does not operate right on with the door closed after being opened. The fan motor for dual-evaporator refrigerators starts after a 50 °F~second delay and when the ambient temperature is higher than 91.4°F, it starts after a minute.</p>	

## REFERENCE INFORMATION

Descriptions of symptoms	Check Points	Corrective Measures
<p>► <b>What can be done when it sends out much smell in the fridge and the freezer compartments after 2 months?</b></p>	<p>When the stored food sends out much smell.</p> <ul style="list-style-type: none"> <li>☞ Check if there is any food sending out sustaining smells. Dried squid, dried laver : Hold on them Pounded garlic : Put it in an airtight container Medical herbs : Make sure they are packed airtight. Replace the old packing or wrap with a new one.</li> <li>Others : Check if the container is sealed or the food is packed airtight.</li> </ul> <ul style="list-style-type: none"> <li>☞ Check if the compartment temperature is normal and the food is contaminated.</li> <li>☞ Check if there are any overflow of side dishes on the shelves or the bottom of the compartments.</li> <li>☞ Put the food sending out much smell in an airtight bag or container.</li> <li>☞ Open the door and ventilate it. Also, clean liners, shelves, containers and door bins.</li> </ul>	
<p>► <b>What is the cause and its counter action for chemical smells with new products?</b></p>	<p>During its delivery to customers, chemical smells from various components could build up inside of the compartments. So, please let the doors open for some time to use the unit.</p>	<p>Precautions : Smells tend to get soaked into the liners or other components. If food generating much smell is stored inside, it would stick onto the liners and other components and it is so difficult to remove the smell. Especially, customers should take care in storing smelly food properly with its sealing being tight during the early period of the product's use.</p>
<p>► <b>What can be done when the smell keeps on even though the deodorizers are cleaned?</b></p>	<ol style="list-style-type: none"> <li>1) Turn off the refrigerator (unplug the unit) and remain the door opened.</li> <li>2) Take out the food stored in the refrigerator. And then, take out all the shelves, door bins and containers, and put them in warm water. After cleaning them by using dish detergents and drying them, put them back to their locations.</li> <li>3) Remove the deodorizer and soak it in warm water more than 4 hours. After drying it in sunlight, put it back to its location.</li> <li>4) Throw away the smell-soaked plastic bags and put the food in new ones.</li> </ol>	
<p>► <b>What causes the funny smell in water?</b></p>	<p>When it tastes and smells funny</p> <ul style="list-style-type: none"> <li>☞ It tastes funny even though it does not smell funny.</li> </ul>	<p>It could happen when remnants of the water filter or organics have been built up in the water tank. So, replace the water filter and the water tank together. If there is no replacement part and the water tank need cleaning, use dish detergents and make sure to clean the inside without any detergents remaining inside.</p>

# SAMSUNG

107, Hanamsandan 6 Beon-Ro,  
Gwangsan-Gu, Gwangju 506-723 Korea  
TEL: 82-62-950-6193, 6896  
FAX: 82-62-950-6859

Europe, CIS, Mideast & Africa: [gspn1.samsungcsportal.com](http://gspn1.samsungcsportal.com)  
Asia: [gspn2.samsungcsportal.com](http://gspn2.samsungcsportal.com)  
North & Latin America: [gspn3.samsungcsportal.com](http://gspn3.samsungcsportal.com)  
China: [china.samsungportal.com](http://china.samsungportal.com)

– This Service Manual is the property of Samsung Electronics Co., Ltd.  
Any unauthorized use of this Manual is punishable under the applicable  
International or domestic law.